



**United States
Department of
Agriculture**

Rural
Utilities
Service

RUS Bulletin 1753F-153
RUS Form 515d

September 2001

Specifications and Drawings for Service Installation at Customer Access Locations

This page is intentionally left blank

UNITED STATES DEPARTMENT OF AGRICULTURE
Rural Utilities Service

BULLETIN 1753F-153

SUBJECT: Specifications and Drawings for Service Installations
at Customer Access Locations, RUS Form 515d

Incorporated by reference in 7 CFR 1755.97

TO: All Telecommunications Borrowers
RUS Telecommunications Staff

EFFECTIVE DATE: September 17, 2001

OFFICE OF PRIMARY INTEREST: Outside Plant Branch,
Telecommunications Standards Division.

AVAILABILITY: This bulletin supersedes RUS Bulletin 345-154,
Specifications and Drawings for Service Entrance and Station
Protector Installation, RUS Form 515g, issued May 25, 1989.
This bulletin can be accessed via the Internet at
<http://www.usda.gov/rus/telecom/publications/bulletins.htm>

PURPOSE: This specification provides Contractors, Engineers, and
RUS Borrowers with assembly unit descriptions, materials,
construction and installation, and drawings for service
installations at customer access locations associated with RUS
Form 515, Telecommunications System Construction Contract.

Roberta D. Purcell
Roberta D. Purcell
Assistant Administrator
Telecommunications Program

8/21/01

Date

RUS Bulletin 1753F-153
Specifications and Drawings for Service Installations at
Customer Access Locations, RUS Form 515d

TABLE OF CONTENTS

	<u>Page</u>
List of Changes.....	i
Part I - Description of Assembly Units and Proposal and Contract Sections	1
Part II - Specifications and Materials.....	7
1. Scope	7
2. General	7
3. Miscellaneous	7
Part III - Specifications for Construction and Installation....	7
1. General	7
2. Aerial Service Entrances	8
3. Buried Service Entrances	8
4. NID	9
List of Construction Drawings and Plans.....	10

INDEX

ASSEMBLY UNITS:

 Underground Cable

CONSTRUCTION:

 Service Entrances

 Station Protector Installation

SPECIFICATIONS AND STANDARDS:

 Outside Plant

WIRE:

 Buried Service

 Drop Parallel Conductor

LIST OF CHANGES

1. Addition of BM50 unit, Buried Service Wire or Cable Installation to Pole-Mounted Wire Terminal Assembly Unit.
2. Provision of suffix "D" to BM60 and BM61 units to indicate directional boring.
3. Provision of suffix "P" to the BM60 unit to indicate plastic pipe.
4. Modification of the BM61 unit allowing the Engineer to specify the maximum bore diameter in parentheses.
5. Provision of suffix "E" to the BM71 unit to indicate extra depth in rock.
5. Modification of Section NI to become Section NID, Network Interface Device Assembly Units. Redefined unit to include protectors as part of the unit, as well as mounting arrangements for mobile home installation.
6. Elimination of Section P. Protectors are now included as part of Section NID.
7. Modification of Section SE as follows:
 - (a) Compensation will be on a per foot basis;
 - (b) Elimination of the SEK unit. This unit is now covered under two separate units: the SEA unit and the BM50 unit.
8. In part III, section 3, changed minimum depth of buried service entrances from 24 inches to 12 inches in soil.
9. In part III, section 4, modified section to cover NID's in place of station protection.
10. Modification of the NID2 and NID3 assembly unit drawings to indicate the Power Company's method of providing the electrical system ground connection.

For editorial or other minor technical changes, refer to the body of the document.

This page is intentionally left blank

**Part I - DESCRIPTION OF ASSEMBLY UNITS AND PROPOSAL AND
CONTRACT SECTIONS**

The Contractor's Proposal form is divided into sections and the sections approved for construction shall be listed in the Construction Agreement by the Owner. The sections are as follows:

- Section BM - Miscellaneous Assembly Units
- Section NID - Network Interface Device Assembly Units
- Section SE - Service Entrance Assembly Units
- Section W - Rearrangement Units
- Section XX - Nonreusable Materials Removal Units
- Section XZ - Reusable Materials Removal Units

Each assembly unit includes only the materials listed on the corresponding Installation and Construction Guide Drawings or description of unit where no drawing exists. The various installation and construction units which are included in the Proposal and upon which quotations are required are defined by the following descriptions:

Section BM - MISCELLANEOUS ASSEMBLY UNITS

Consists of all labor and material to construct and install the units defined individually below required for the installation and construction of the service entrance portions of the Project:

- BM50() Buried Service Wire or Cable Installation to Pole-Mounted Wire Terminal Assembly Unit - Consists of the necessary labor and material to install a buried wire or cable from a buried plant housing to a pole mounted wire terminal. This unit includes the installation of pole mounted buried wire or cable, a pole mounted wire terminal, and the necessary wire work at the wire terminal (see assembly unit drawing BM50). Pair count of the terminal size shall be indicated in the parentheses. Installation of the buried plant housing and splicing of the pole mounted buried wire or cable inside the buried plant housing shall be compensated under separate units.
- BM60() Underground Pipe Crossing Assembly Unit - Consists of one (1) lineal foot [0.305 meters (m)] of steel pipe, with the inside diameter in inches (meters) specified in parentheses, installed in place. This unit includes the pushing of pipe and any excavation, backfilling and tamping necessary for the installation of the pipe. The pipe shall be installed at the depth specified by the Engineer. The installed pipe shall be free of any sharp

projections to avoid damage to the outer jacket of the buried cable or wire during its installation in the pipe. The contractor will be compensated for labor and material for the buried cable or wire under separate units. Options designated by the following suffixes apply:

<u>Suffix</u>	<u>Description</u>
D	Directional boring required.
P	Plastic pipe required.

BM61() Underground Non-Pipe Crossing Assembly Unit - Consists of the labor in providing a hole in soil one (1) foot (0.305 m) in length and of a diameter in inches (meters) specified in parentheses. The depth of the hole below the surface of the ground shall be specified by the Engineer. This unit includes any excavation, backfilling and tamping necessary for the installation. This unit may be used where the permanent installation of a steel or plastic pipe under the BM60 unit is not required. The contractor will be compensated for labor and material for the buried cable or wire under separate units. Where directional boring is required, the unit shall be suffixed by the letter "D".

BM71 Rock Excavating Unit - Consists of one (1) lineal foot (0.305 m) of trenching, blasting, sawing, etc., measured parallel to the surface of the ground, in rock, including excavation, backfilling and tamping to place cable or wire to the depth specified in the Specifications. This unit includes all material and labor required in the repair and/or replacement of streets, roads, sidewalks, drives, fences, lawns, shrubbery, watermains, pipes, pipelines and contents, underground power and telecommunications facilities and any other property damaged by the excavating, except loss or damage to crops, gardens, trees or ornamental flowers in the construction corridor necessarily incident to the construction of the Project and not caused by the negligence of the Contractor. This unit will be specified by the Engineer only when field conditions at the site show the existence of rock to a depth required by the specification, which cannot be trenched, plowed or ripped. If extra depth is required, the unit shall be suffixed by "E()", where the required depth in rock shall be shown inside the parentheses.

The contractor will be compensated for labor and material for the buried cable or wire under separate units.

BM83 Buried Service Guard - Consists of a guard, including fasteners, mounted in place over the buried wire or cable and/or ground wire, as shown on the Construction Sheets (see unit drawing BM83).

Section NID - NETWORK INTERFACE DEVICE ASSEMBLY UNITS

Consists of a network interface device (NID) installed in place, with necessary hardware and jumpers connected, and where required, furnishing and installing a ground and/or bond in accordance with the Construction Sheets. The assembly units are equipped with modular jacks and fuseless protectors.

The assembly unit is defined as follows:

NID () Network Interface Device

The number specified in the parentheses shall indicate the number of modular jacks and the number of fuseless protectors

The mounting arrangement suffixes for the NID unit are as follows:

<u>Suffix</u>	<u>Description</u>
1	Electric System Ground with Bond to Metallic Water Pipe System (see unit drawing NID1)
2	Electric System Ground Rod (see unit drawing NID2)
3	Electric System Grounding Conductor (see unit drawing NID3)
4	Telco Ground Rod with Sub-surface Bond to Electric Ground (see unit drawing NID4)
5	Telco Ground Rod with Above-surface Bond to Electric Ground (see unit drawing NID5)
6	Telco Ground Rod with Bond to Water Pipe - no Electric Service at Site (see unit drawing NID6)
7	Mobile Home Installation - within 35 ft of Electric Service Equipment (see unit drawing NID7)

- 8 Mobile Home Installation - over 35 ft from
Electric Service Equipment
(see unit drawing NID7)
- G Indicates Gas-Tube station protectors are to be
Furnished
- I Indicates inside mounting (see detailed drawings
as specified by the Engineer)

Examples:

- NID(2)3 NID containing 2 modular jacks and 2 fuseless
station protectors with electric system
grounding conductor
- NID(6)G1 NID containing 6 modular jacks and 6 fuseless
station protectors having gas tube arrestors
with electric system ground with bond to
metallic water pipe system.

Section SE - SERVICE ENTRANCE ASSEMBLY UNITS

Consists of one (1) foot (0.305 m) of service entrance wire or cable in place from the network interface device (NID) to either filled terminal blocks in a ready-access closure or buried plant housing; or buried cable pair. This unit includes all clamps, rings, hooks and other hardware required for attachment to poles, buried plant housings and buildings. This unit does not include the labor and material for connecting the wire or cable to the NID unless specified by the Engineer and suffixed by the letter "P". This unit does not include cable splicing. For compensation purposes, the length of service entrance wire or cable includes the sum of the distance between supporting structures and when required the vertical runs on buildings and poles. The service entrance units are further defined as follows:

- SEA Aerial Service Entrance from Aerial Cable Assembly Unit
- This unit includes the labor and material for an aerial service entrance extending from aerial plant. It includes the labor and material for the installation of aerial service wire connected to the filled terminal blocks of the ready access closure or pole mounted wire terminal in accordance with the Construction Sheets. Tree trimming necessary for installing the aerial service wire is also included and shall be performed in accordance with the instructions of the Engineer.

SEB Buried Service Entrance Assembly Unit - This unit includes the labor and material for placement of buried service wire or cable to the depth set forth in the specifications and the backfilling and tamping of the trench and for the repair and/or replacement of all fences, shrubbery, drives, lawns, watermains, pipes, sidewalks, pipelines and contents, underground power and telecommunications facilities, pavements, roadways, buried sewerage and drainage facilities, and any other property damaged during the installation of Service Entrances.

Suffix Description

P When the units above are suffixed with the letter "P" the labor and material for connecting the conductors, and the shield for buried service wire or cable, to the station protector of the NID are included. This work shall be done in accordance with the Construction Sheets.

Each service entrance assembly unit is listed in accordance with the number of pairs and gauge of conductors. Each unit is prefixed by the letters SE. The following illustrations indicate the method of designating the material required.

SEAL-18 Indicates an aerial service entrance assembly unit from an aerial cable utilizing a one-pair, parallel conductor, 18 gauge aerial service wire.

SEB2-22 Indicates a buried service entrance assembly unit utilizing a two-pair, 22 gauge filled buried wire.

SEBP2-22 Indicates a buried service entrance assembly unit utilizing a two-pair, 22 gauge filled buried wire connected to the station protector of the NID.

Section W - REARRANGEMENT UNITS

Specific rearrangement units shall be designated and described by the Engineer on the "List of Special Arrangement Units" table of RUS Form 515. Existing plant assembly units to be rearranged are designated by a prefix "W".

Section XX - NONREUSABLE MATERIALS REMOVAL UNITS

These units cover the furnishing of all labor for the removal of construction assembly units from existing lines, and transportation of the removed materials for proper disposal. The Contractor will be permitted to use the most economical method of

removing these units. The removal units are designated by the prefix "XX" followed by the assembly unit designation of the unit to be removed.

Section XZ - REUSABLE MATERIALS REMOVAL UNITS

These units cover the furnishing of all labor for the removal of construction assembly units from existing lines and all labor and transportation of the removed materials to a location designated by the Owner. The Contractor will be charged by the Owner for the materials removed under this section at the unit material values shown in column 2 of the "Value and Disposition of Units to be Removed" table of RUS Form 515. The number of units to be charged to the Contractor and the extended value of these units are shown in columns 3 and 4. Such charges will be placed against the Contractor as assembly units are removed and the unit material values will be deducted from the total value of assembly units constructed on this project for determination of the work accomplished for purposes of the monthly progress payments to the Contractor. Of the assembly units listed in the "Value and Disposition of Units to be Removed" table to be removed from existing lines certain units are to be reused in the construction of the project. The quantity of such units to be reused is listed in the "Value and Disposition of Units to be Removed" table, column 5. These units where installed in the project will be inventoried as new assembly units and compensated for at the unit bid prices. The quantity of assembly units listed in column 6 of the "Value and Disposition of Units to be Removed" table is the maximum quantity of removed assembly units that are to be returned to the Owner for credit which will be allowed at the unit material prices in column 2. Column 7 indicates the extended value of the units to be returned to the Owner. The Contractor will be allowed credit for assembly units listed in column 6 which, in the opinion of the Engineer, have not been damaged by the Contractor in removal and handling. Such credits will be allowed the Contractor as the assembly units are returned to a location designated by the Owner and shall be added to the total value of installed assembly units for determination of work accomplished for the purposes of the monthly progress payments to the Contractor. The removal units are specified by the prefix "XZ" followed by the assembly unit designation of the existing assembly unit to be removed.

Part II - SPECIFICATIONS FOR MATERIALS**1. SCOPE**

This part of the specifications is concerned with the various materials required for the construction of customer access service installations of the rural telecommunications system as shown on the Plans, Specifications, and Construction Sheets.

2. GENERAL

All materials used in the construction of the rural telecommunications system except those listed in Paragraph 3 below shall be listed in RUS Informational Publication (IP) 344-2, "List of Materials Acceptable for Use on Telecommunications Systems of RUS Borrowers," unless specific written approval has been granted by the Administrator.

3. MISCELLANEOUS

Items for which categories do not appear in RUS IP 344-2, "List of Materials Acceptable for Use on Telecommunications Systems of RUS Borrowers," shall be of a quality suitable for the application for which they are intended.

Part III - SPECIFICATIONS FOR CONSTRUCTION AND INSTALLATION**1. GENERAL**

1.1 All construction and installation work shall be done in a thorough and workmanlike manner in accordance with the Plans, Specifications and Construction Sheets and shall be subject to acceptance by the Owner and the Administrator.

1.2 All material to be used in construction of the Project shall be stored so as to be protected from deteriorating effects of the elements.

1.3 All service wires and cables, and accessory materials used in the construction of the Project shall be handled with care. Each reel of service wire or cable shall be inspected for damage. Prior to installation, all damage shall be repaired to the satisfaction of the Engineer. If reel wrap is present, the reel wrap shall remain intact on the reel until the wire or cable is ready to be placed.

1.4 Deviations from the Plans, Specifications and Construction Sheets shall not be permitted except upon written permission of the Engineer.

1.5 The latest revision of the National Electrical Safety Code (NESC) and the National Electrical Code (NEC) shall be followed in every case except where local regulations are more stringent, in which case local regulations shall govern.

1.6 The Contractor shall maintain conductor polarity (tip and ring) identification at the main distributing frame, cable terminals, wire terminals, terminal blocks, and for Service Entrances at the network interface device (NID), all in accordance with the Specifications and Construction Sheets.

2. AERIAL SERVICE ENTRANCES

2.1 Aerial service wires shall be installed in accordance with RUS Service Installation Standard Bulletin 1753F-801(PC-5A), and the Construction Sheets.

2.2 All clearances shall comply with the applicable requirements of the NESC, and NEC, or local laws, or ordinances, whichever are most stringent.

3. BURIED SERVICE ENTRANCES

3.1 Buried service entrances shall be installed at the depth listed below unless otherwise specified by the Engineer.

minimum depth in soil	-	12 inches (in.) [305 millimeters (mm)]
minimum depth in ditches (see guide drawing 975)	-	36 in. (914 mm)
minimum depth in rock	-	3 in. (76 mm)

3.2 Buried services shall contact the building as near as practicable to the NID or proposed NID location.

3.3 Buried services shall be located to avoid damage from lawn mowers, animals, etc., and, where deemed necessary by the Engineer, shall be guarded.

3.4 The method of installation is shown on the Construction Sheets.

3.5 Buried services shall be installed against a foundation wall or pillar to provide adequate support and mechanical protection.

3.6 The buried service conductors shall be terminated in the NID, when specified by the Engineer, as shown on the Construction Sheets.

4. NID

4.1 NID's shall be installed and grounded in accordance with RUS Service Installation Standard Bulletin 1753F-801(PC-5A), and the Construction Sheets. They shall also be installed in such a manner as to coordinate with acceptable, available grounding electrodes, such as to meet the existing applicable requirements of the NEC or local laws or ordinances whichever are more stringent.

4.2 The NID shall be located as directed by the Engineer. The choice of location shall be chosen to facilitate common grounding with existing (code) acceptable grounding electrodes by obtaining the best compromise between the length of horizontal service wire or cable run and length of protector grounding conductor wire run.

4.3 Where a grounding conductor or a bonding conductor is to be buried, the trench shall be dug as close to the side of the building as practicable. Trenches shall be properly backfilled.

LIST OF CONSTRUCTION DRAWINGS AND PLANSAssembly Unit Drawings

BM50	Buried Service Wire or Cable Installation to Pole-Mounted Wire Terminal
BM83	Buried Service Guard
NID1	Electric System Ground with Bond to Metallic Water Pipe System
NID2	Electric System Ground Rod
NID3	Electric System Grounding Conductor
NID4	Telco Ground Rod with Sub-surface Bond to Electric Ground
NID5	Telco Ground Rod with Above-surface Bond to Electric Ground
NID6	Telco Ground Rod with Bond to Water Pipe - No Electric Service at Site
NID7	Mobile Home Installation - within 35 ft of Electric Service Equipment
NID8	Mobile Home Installation - over 35 ft from Electric Service Equipment

Construction Guide Drawings

962-1	Buried Service Wire - Termination of Shield and Conductors on Station Protector Binding Posts of NID
963-2	Bonding Buried Service Wire at Station Protector of NID - (Service Wire Shield Bonding Connector)

NOTE: On the Assembly Unit and Construction Guide Drawings an asterisk (*) in the ITEM column indicates items that are no longer listed in RUS IP 344-2, "List of Materials Acceptable for Use on Telecommunications Systems of RUS Borrowers."

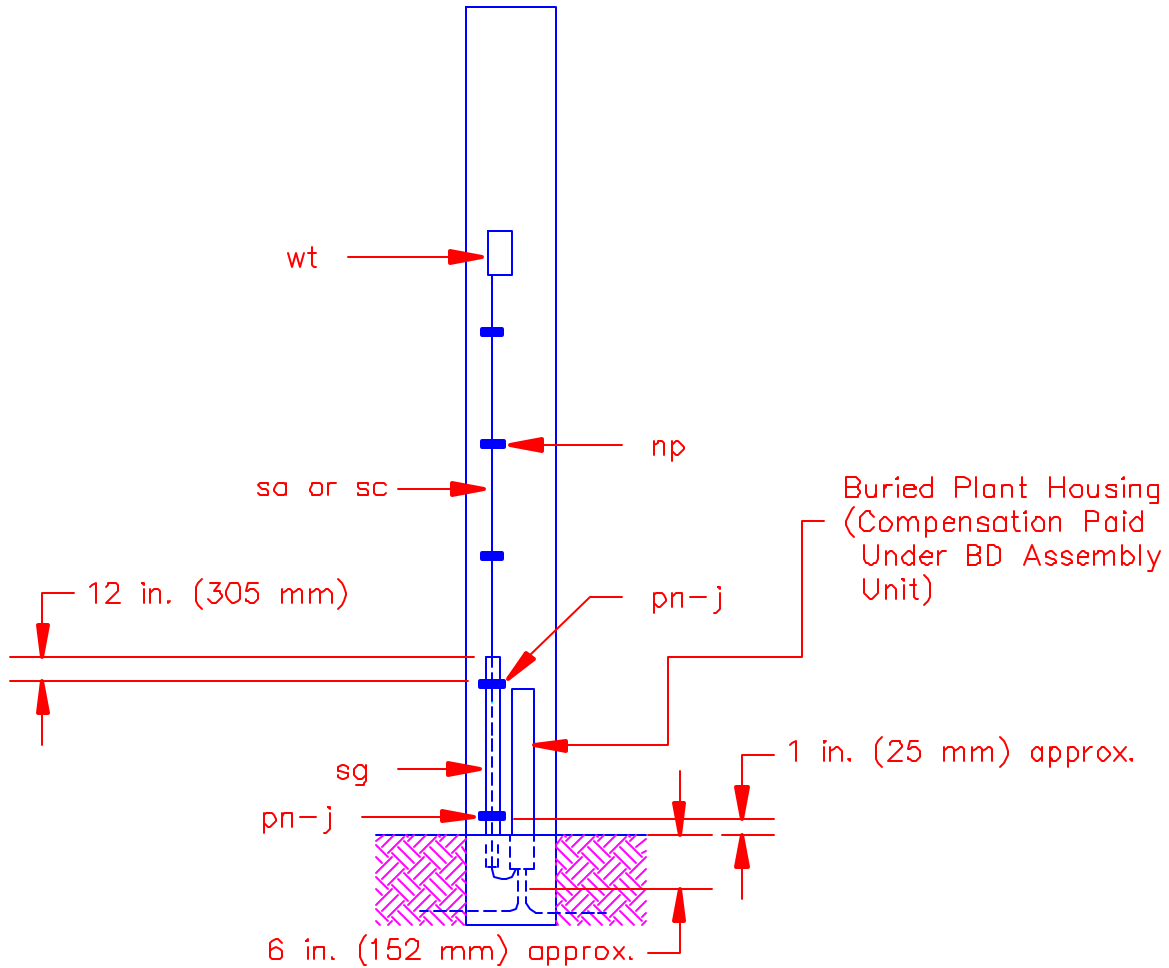

ITEM	MATERIALS	REQUIRED
wt	Terminal, wire, filled, unprotected, pole-mounted (specify pair size)	1
*pn	Strap, rise guard	2
*np	Clamp, cable (1-one hole, offset)	as req'd
sa or sc	Wire or cable, filled, buried	as req'd
sg	Guard, riser, 1"ID*8'	as req'd
j	Screws, lag (size as required)	4
RURAL TELECOMMUNICATIONS CONSTRUCTION PRACTICES BURIED SERVICE WIRE OR CABLE INSTALLATION TO POLE-MOUNTED WIRE TERMINAL		
Scale: NTS		March 2001
		BM50

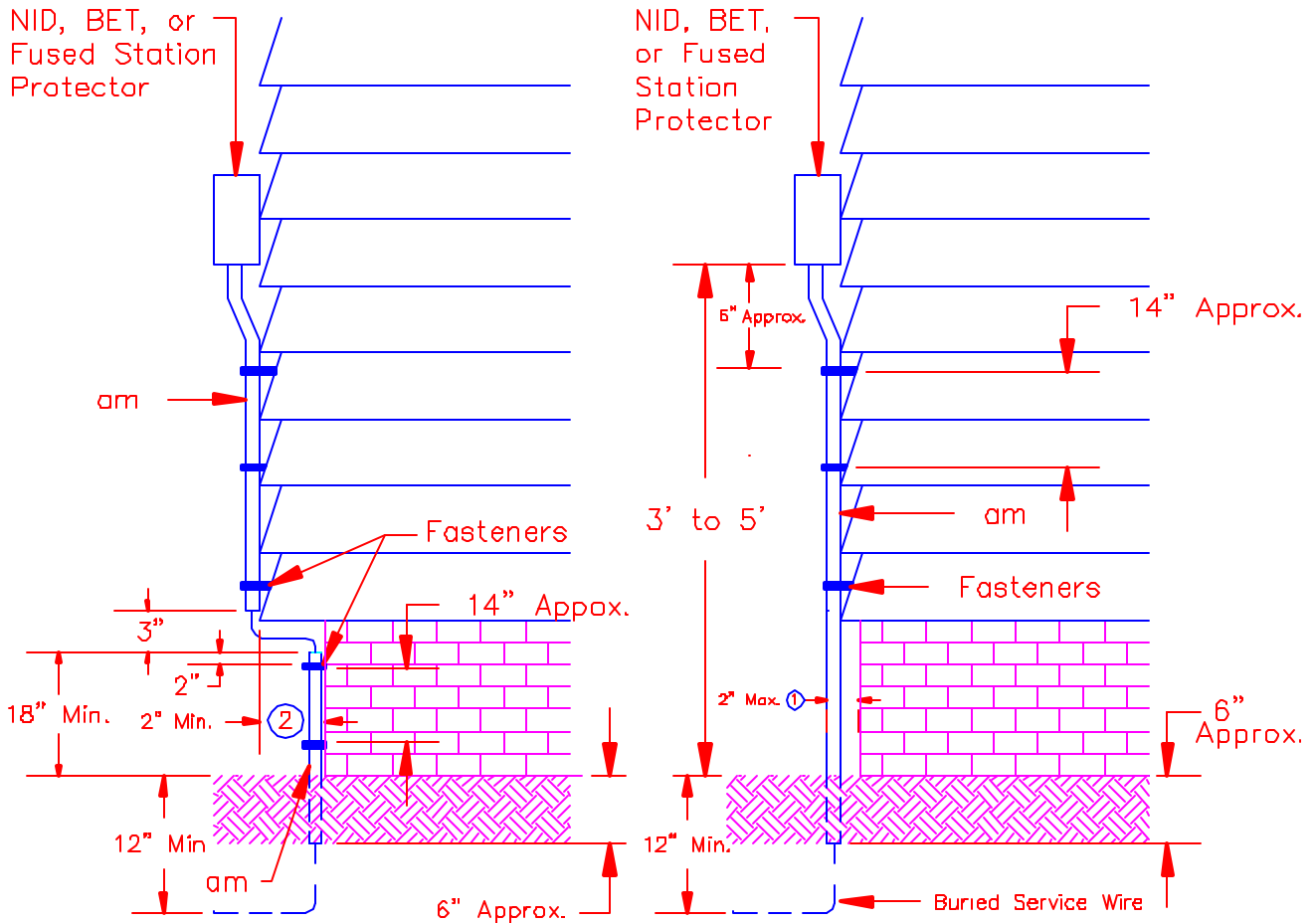

Notes:

- ①. Where an obstruction of less than 2 in. is encountered, the buried service guard (item am) shall be extended from the NID, BET, or fused protector to 6 in. below the ground.
- ②. Where an obstruction of greater than 2 in. is encountered, the buried service guard (item am) shall be divided as shown (from the NID, BET, or fused protector to the obstruction, and from 3 in. below the obstruction to 6 in. below the ground). In lieu of divided service guards (item am), a continuous flexible conduit may be used from the NID, BET, or fused protector to 6 in. below the ground.
- ③. For converting English units to metric units use 1 in. = 25.4 mm and 1 ft = 0.3048 m.

ITEM	MATERIAL	NO. REQ'D
am	Guard, buried service (including fasteners)	1
RURAL TELECOMMUNICATIONS CONSTRUCTION PRACTICES BURIED SERVICE GUARD		
Scale: NTS		March 2001
		BM83

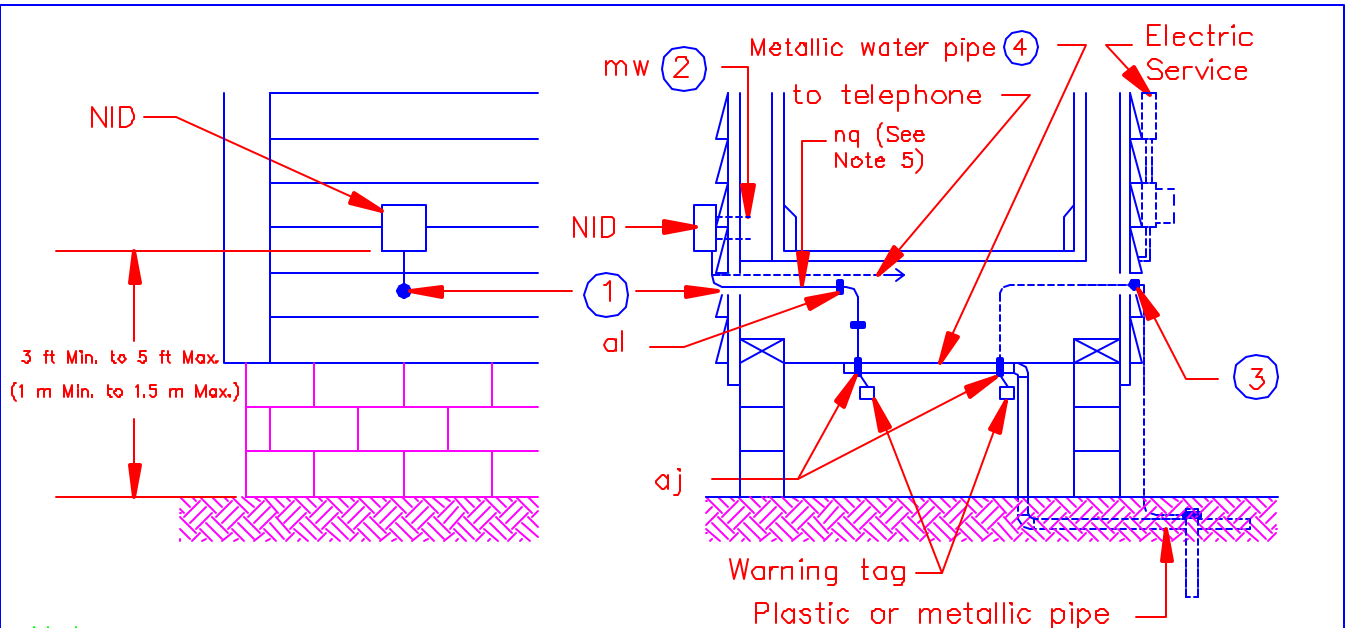

Notes:

- ①. Holes shall be sloped slightly upward and wires shall be taped to a tight fit.
- ②. When mounting NID on masonry surface, screw expansion anchors or equivalent manual or machine-driven fastening devices shall be used.
- ③. Bonding wire from the metallic water pipe to electric service ground shall be installed by telecommunications customer's qualified electrician in a manner that is in accordance with the National Electrical Code or more stringent local code, as applicable, prior to installation of NID.
- ④. Metallic water pipe shall be electrically continuous from point of NID grounding conductor attachment to a point where the metallic water pipe is bonded to the electric system.
- ⑤. The ground wire conductor size used shall be chosen for the installation based on the number of telecommunications circuits installed at the customer location. See RUS 1753F-801(PC-5A) for correct conductor size.

ITEMS	MATERIALS	NO REQ'D
NID	NID, outside station (specify no. of modular jacks/fuseless protectors)	1
aj	Clamps, ground rod and pipe	1
*al	Staples or nails, ground wire	as req'd
*nq	Wire, ground, insulated (See Note 5 for conductor size)	as req'd
*mw	Screws, stainless steel, wood	as req'd
-	Tag, warning	1

RURAL TELECOMMUNICATIONS CONSTRUCTION PRACTICES
 OUTSIDE NETWORK INTERFACE DEVICE (NID) – ELECTRIC
 SYSTEM GROUND WITH BOND TO METALLIC WATER PIPE

Scale: NTS

March 2001

NID1

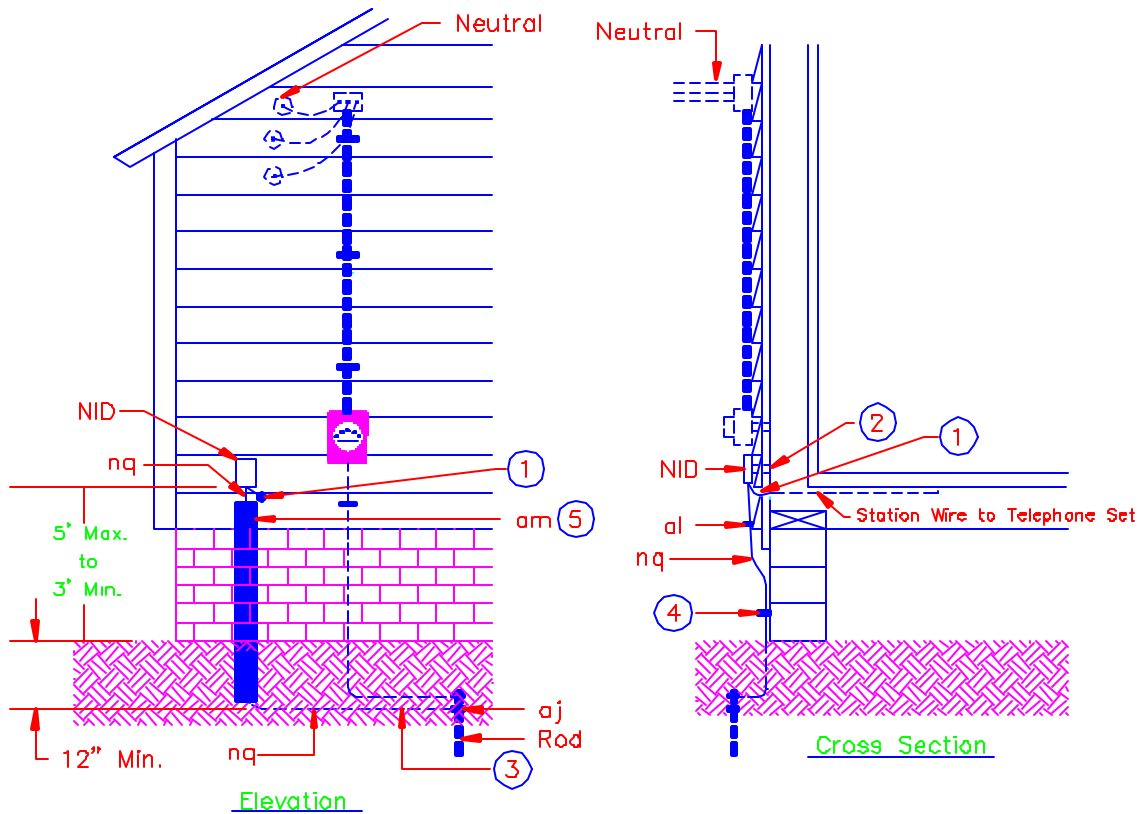

Notes:

- ①. Holes shall be sloped slightly upward and wires shall be taped to a tight fit.
- ②. When mounting NID on masonry surface, screw expansion anchors or equivalent manual or machine-driven fastening devices shall be used.
- ③. Ground wire shall be connected to the electric service ground rod by means of pipe-type ground clamp. Be sure the electric system ground is in compliance with existing applicable codes. Electric system grounding conductor attachment shall not be disturbed.
- ④. Ground wire shall be fastened to the building 4 in. above the grade.
- ⑤. Grounding conductor shall be guarded (Item am) from physical damage where necessary. Plastic guards are recommended. If metallic guards are used both ends of the guard shall be bonded to the NID grounding conductor.
- ⑥. The ground wire conductor size used shall be chosen for the installation based on the number of telco circuits to be installed at the customer location. See RUS Bulletin 1753F-801(PC-5A) for correct conductor size.
- ⑦. For converting English units to metric units use 1 in. = 25.4 mm and 1 ft = 0.3048 m

ITEMS	MATERIALS	NO. REQ'D
NID	NID, outside station (specify no. of modular jacks/fuseless protectors)	1
aj	Clamps, ground rod and pipe	1
*al	Staples or nails, ground wire	as req'd
*nq	Wire, ground, insulated (See Note 6 for conductor size)	as req'd
*mw	Screws, stainless steel, wood	as req'd
am	Guard, buried service (including fasteners)	as req'd
RURAL TELECOMMUNICATIONS CONSTRUCTION PRACTICES OUTSIDE NETWORK INTERFACE DEVICE (NID) ELECTRIC SYSTEM GROUND ROD		
Scale: NTS		March 2001
		NID2

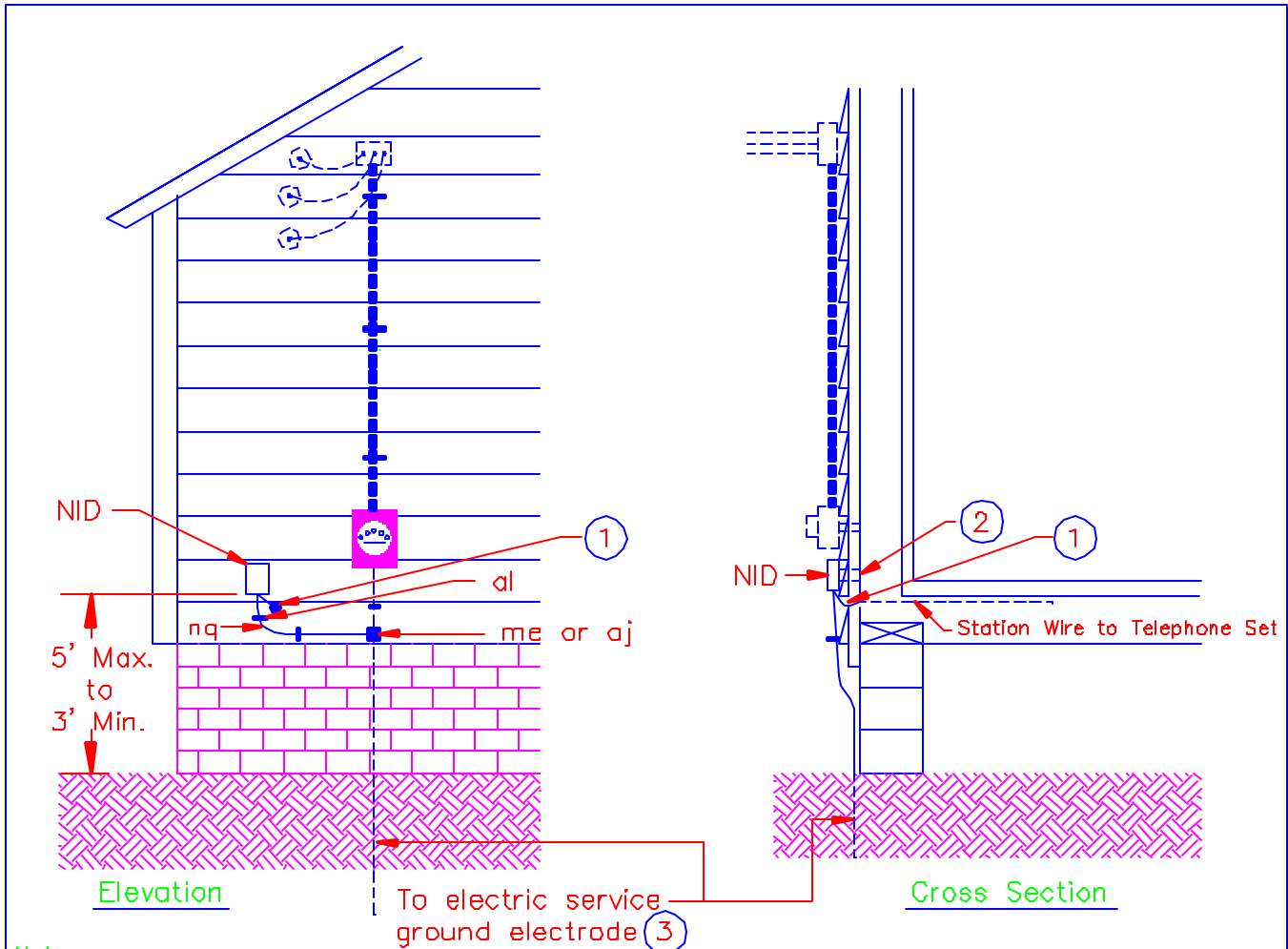

Notes:

- ① Holes shall be sloped slightly upward and wires shall be taped to a tight fit.
- ② When mounting NID on masonry surface, screw expansion anchors or equivalent manual or machine-driven fastening devices shall be used.
- ③ Ground wire shall be connected to the electric service grounding conductor or to the metallic conduit (enclosure) covering the electric service grounding conductor by means of a grounding connector or pipe-type clamp, Item "me" or "aj", as appropriate. Be sure electric system grounding is in compliance with existing applicable codes. Electric ground attachments shall not be disturbed..
- ④ The ground wire conductor size used shall be chosen for the installation based on the number of telecommunications circuits to be installed at the customer location. See RUS Bulletin 1753F-801(PC-5A) for correct conductor size.

ITEMS	MATERIALS	NO. REQ'D
NID	NID, outside station (specify no. of modular jacks/fuseless protectors)	1
aj	Clamp, ground rod and pipe	1
*al	Staples or nails, ground wire	as req'd
*mw	Screws, stainless steel, wood	as req'd
*nq	Wire, ground, insulated, (See Note 4 for conductor size)	as req'd
me	Connector, grounding compression type	as req'd
For converting English units to metric units use 1 in. = 25.4 mm and 1 ft = 0.3048 m.		
RURAL TELECOMMUNICATIONS CONSTRUCTION PRACTICES OUTSIDE NETWORK INTERFACE DEVICE (NID) ELECTRIC SYSTEM GROUNDING CONDUCTOR		Scale: NTS
		March 2001
		NID3

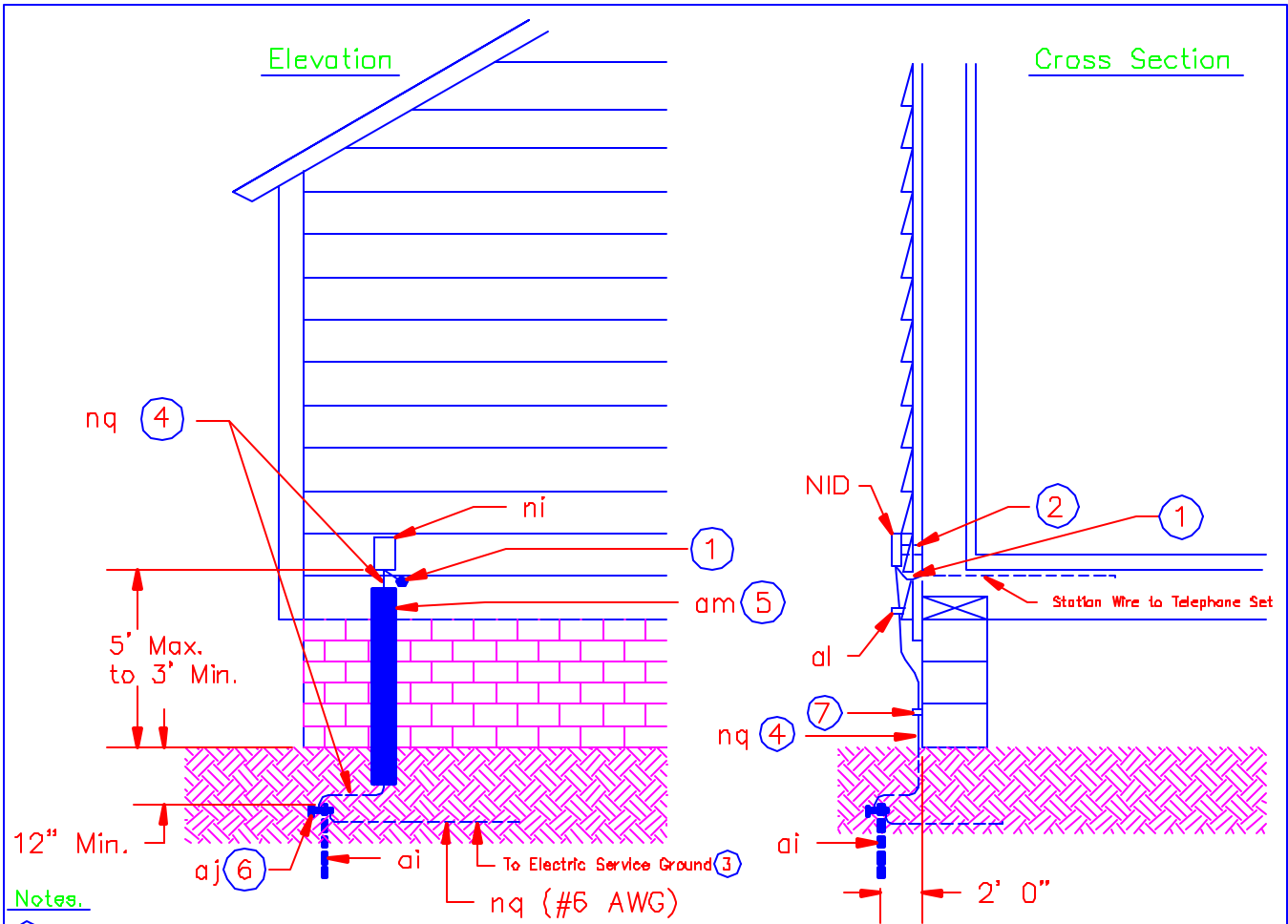

Notes.

- ① Holes shall be sloped slightly upward and wires shall be taped to a tight fit.
- ② When mounting NID on masonry surface, screw expansion anchors or equivalent manual or machine-driven fastening devices shall be used
- ③ Bonding wire shall be connected to the electric service grounding conductor or the electric service grounding electrode by means of a grounding connector or pipe-type clamp, Item "me" or "aj", as appropriate. Be sure electric system ground is in compliance with existing applicable codes. Electric ground attachments shall not be disturbed.
- ④ The ground wire conductor size used shall be chosen for the installation based on the number of telco circuits to be installed at the customer location. See RUS Bulletin 1753F-801(PC-5A) for correct conductor size.
- ⑤ Grounding conductor shall be guarded (with Item "am") from physical damage, where necessary. Plastic guards are recommended. If metallic guards are used both ends of the guard shall be bonded to the NID grounding conductor.
- ⑥ One clamp may be used if it is listed by Underwriter's Laboratories (UL) or other acceptable organizations for connecting two wires, otherwise two UL or other acceptable organization listed clamps must be used.
- ⑦ Ground wire shall be fastened to building 4 in. above grade.

ITEMS	NO. REQ'D	MATERIALS	ITEMS	NO. REQ'D	MATERIALS
			*mw	as req'd	Screws, stainless steel, wood
NID	1	NID, outside station (specify no. of modular jacks/fuseless protectors)	*nq	as req'd	Wire, ground, insulated, (See Note 4 for conductor size)
ai	1	Rod, ground, 1/2" x 5' 0" min.	me	as req'd	Connector, grounding
*ai	as req'd	Staples or nails, ground wire	am	as req'd	Guard, buried service (including fastners)
*nq	as req'd	Wire, ground, bare, #6 AWG copper	aj	1	Clamps, ground rod and pipe

For converting English units to metric units use
 1 in. = 25.4 mm and 1 ft = 0.3048 m.

RURAL TELECOMMUNICATIONS CONSTRUCTION PRACTICES
 OUTSIDE NETWORK INTERFACE DEVICE (NID) - TELCO GROUND
 ROD WITH SUB-SURFACE BOND TO ELECTRIC GROUND

Scale: NTS

March 2001

NID4

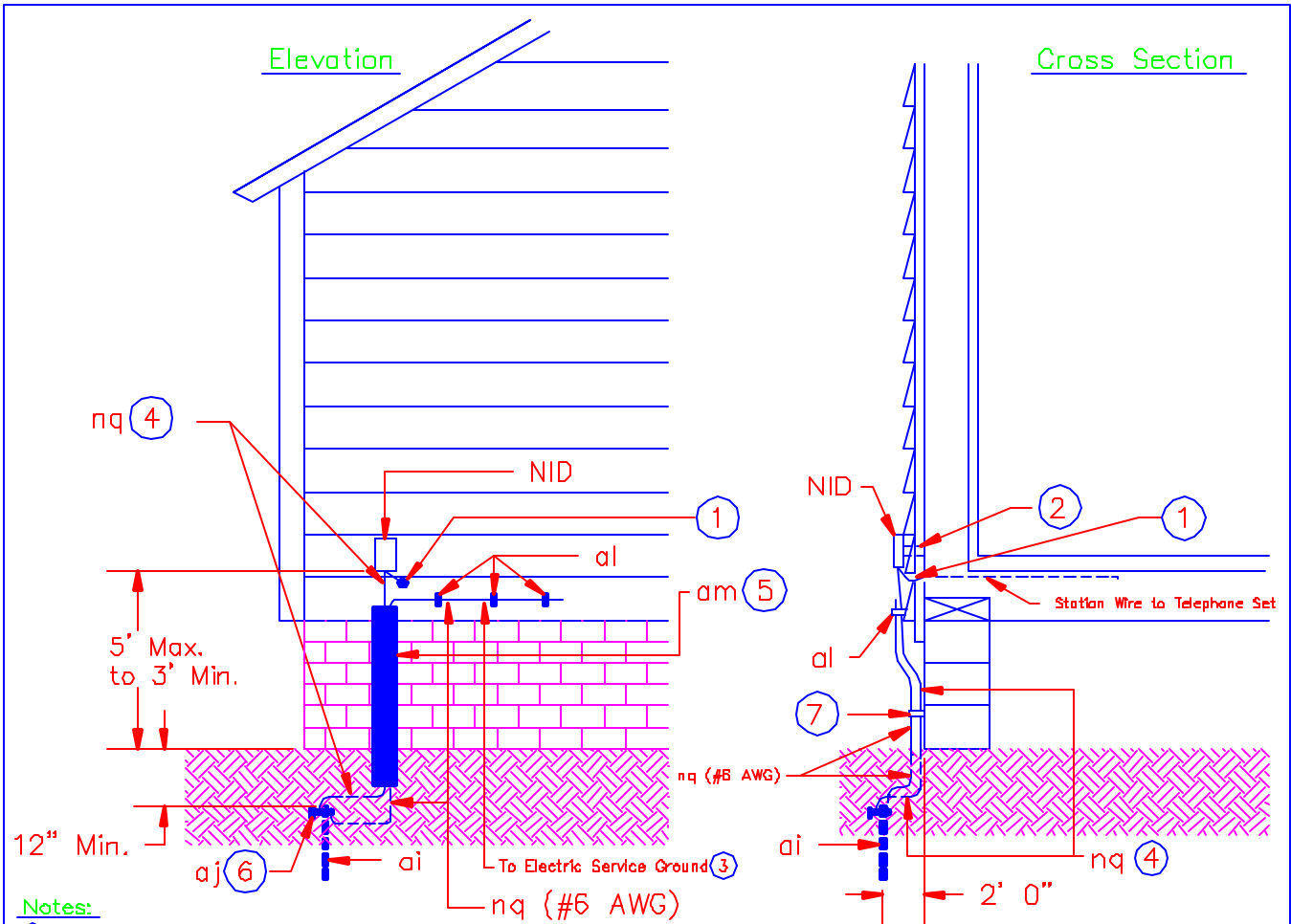

Notes:

- ①. Holes shall be sloped slightly upward and wires shall be taped to a tight fit.
- ②. When mounting NID on masonry surface, screw expansion anchors or equivalent manual or machine-driven fastening devices shall be used.
- ③. Bonding wire shall be connected to the electric service grounding conductor or to the metallic conduit (enclosure) covering the electric service grounding conductor or the electric service grounding electrode by means of a grounding connector or pipe-type clamp, Item "me" or "aj", as appropriate. Be sure electric system ground is in compliance with existing applicable codes. Do not disturb electric ground attachments.
- ④. The ground wire conductor size used shall be chosen for the installation based on the number of telco circuits to be installed at the customer location. See RUS Bulletin 1753F-801(PC-5A) for correct conductor size.
- ⑤. Grounding conductor shall be guarded (with Item "am") from physical damage, where necessary. Plastic guards are recommended. If metallic guards are used both ends of the guard shall be bonded to the NID grounding conductor.
- ⑥. One clamp may be used if it is listed by Underwriter's Laboratories (UL) or other acceptable organizations for connecting two wires, otherwise two UL or other acceptable organization listed clamps must be used.
- ⑦. Ground wire shall be fastened to building 4 in. above grade.

ITEMS	NO. REQ'D	MATERIALS	ITEMS	NO. REQ'D	MATERIALS
			*mw	as req'd	Screws, stainless steel, wood
NID	1	NID, outside station (specify no. of modular jacks/fuseless protectors)	*nq	as req'd	Wire, ground, insulated, (See Note 4 for conductor size)
ai	1	Rod, ground, 1/2" x 5' 0" min.	me	as req'd	Connector, grounding
*al	as req'd	Staples or nails, ground wire	am	as req'd	Guard, buried service (including fasteners)
*nq	as req'd	Wire, ground, insulated, #6 AWG copper	aj	1	Clamp, ground rod and pipe

For converting English units to metric units use
 1 in. = 25.4 mm and 1 ft = 0.3048 m.

RURAL TELECOMMUNICATIONS CONSTRUCTION PRACTICES
 OUTSIDE NETWORK INTERFACE DEVICE (NID) - TELCO GROUND
 ROD WITH ABOVE-SURFACE BOND TO ELECTRIC GROUND

Scale: NTS

March 2001

NID5

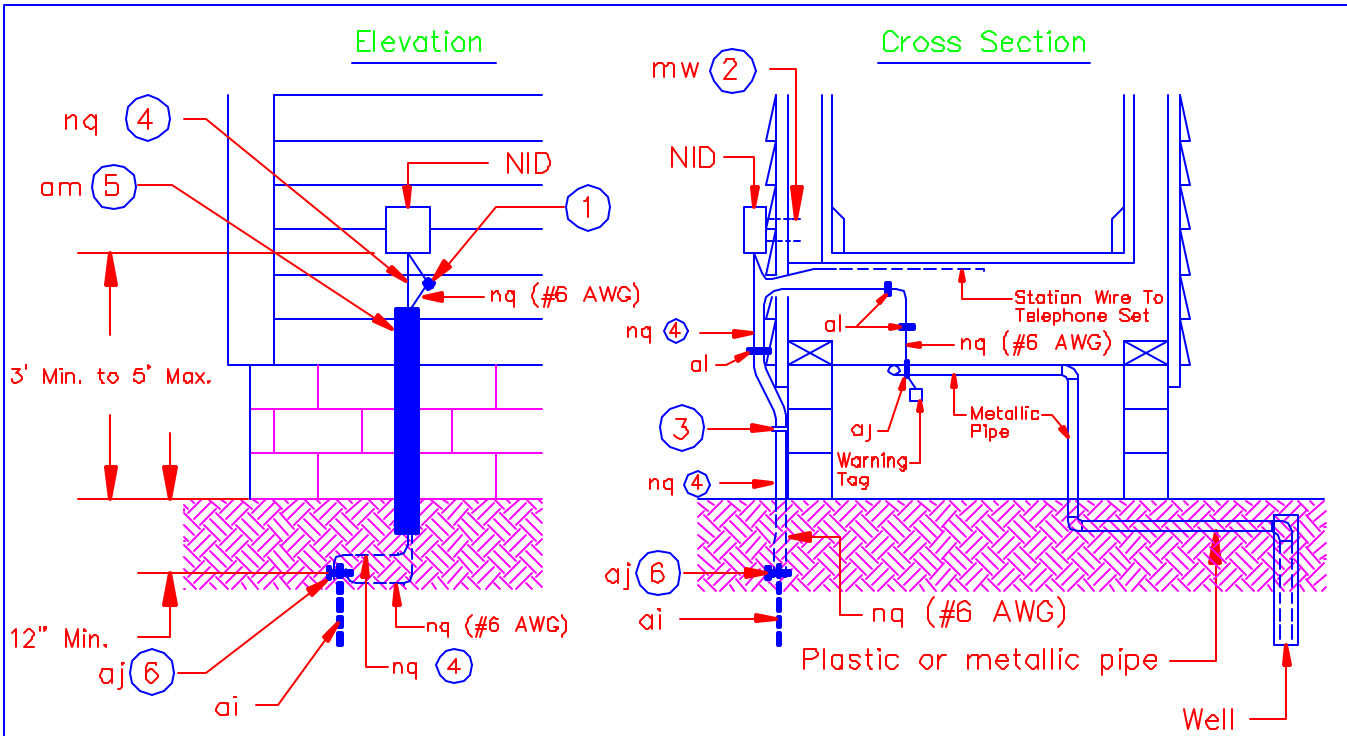

Notes.

1. Holes shall be sloped slightly upward and wires shall be taped to a tight fit.
2. When NID on masonry surface, screw expansion anchors or equivalent manual or machine-driven fastening devices shall be used.
3. Ground wire shall be fastened to building 4 in. above grade.
4. The ground wire conductor size used shall be chosen for the installation based on the number of telco circuits to be installed at the customer location. See RUS Bulletin 1753F-801(PC-5A) for correct conductor size.
5. Grounding and bonding conductors shall be guarded (with Item "am") from physical damage, where necessary. Plastic guards are recommended. If metallic guards are used both ends of the guard shall be bonded to the NID grounding conductor.
6. One clamp may be used if it is listed by Underwriter's Laboratories (UL) or other acceptable organizations for connecting two wires, otherwise two UL or other acceptable organization listed clamps must be used.

ITEMS	NO. REQ'D	MATERIALS	ITEMS	NO. REQ'D	MATERIALS
			*mw	as req'd	Screws, stainless steel, wood
NID	1	NID, outside station (specify no of modular jacks/fuseless protectors)	-	1	Warning tag
ai	1	Rod, ground, 1/2" x 5' 0" min.	*nq	as req'd	Wire, ground, insulated, (See Note 4 for conductor size)
aj	2	Clamps, ground rod and pipe	*nq	as req'd	Wire, ground, insulated, #6 AWG copper
*al	as req'd	Staples or nails, ground wire	am	as req'd	Guard, buried service (including fasteners)

For converting English units to metric units use
 1 in. = 25.4 mm and 1 ft = 0.3048 m.

RURAL TELECOMMUNICATIONS CONSTRUCTION PRACTICES
 OUTSIDE NETWORK INTERFACE DEVICE (NID) - TELCO
 GROUND ROD WITH BOND TO WATER PIPE -
 NO ELECTRIC SERVICE AT SITE

Scale: NTS

March 2001

NID6

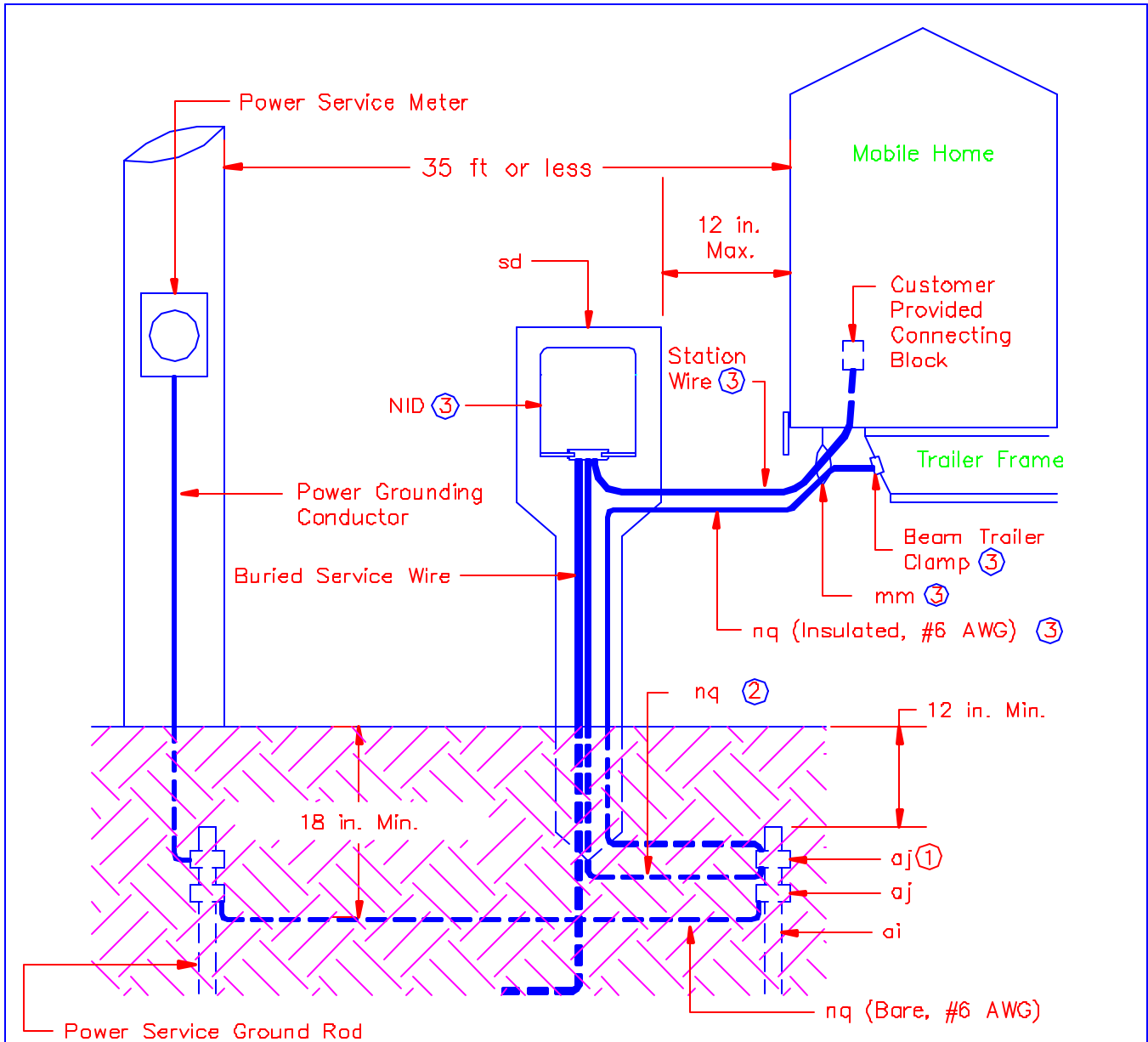

Notes:

- ① One clamp may be used if it is listed by Underwriter's Laboratories (UL) or other acceptable organizations for connecting two wires, otherwise two UL or other acceptable organization listed clamps must be used.
- ② The ground wire conductor size used shall be chosen for the installation based on the number of telco circuits to be installed at the customer location. See RUS Bulletin 1753F-801(PC-5A) for correct conductor size.
- ③ See RUS Bulletin 1753F-801(PC-5A) for terminations.

ITEMS	NO. REQ'D	MATERIALS	ITEMS	NO. REQ'D	MATERIALS
			*nq	as req'd	Wire, ground, Insulated, #6 AWG copper
NID	1	NID, outside station (specify no. of modular jacks/fuseless protectors)	*nq	as req'd	Wire, ground, insulated (See Note 2 for conductor size)
ai	1	Rod, ground, 1/2" x 5' 0" min.	*nq	as req'd	Wire, ground, bare #6 AWG copper
aj	2	Clamps, ground rod and pipe	sd	1	Post, mobile home
*mm	1	Drive ring	-	1	Clamp, trailer beam

For converting English units to metric units use
 1 in. = 25.4 mm and 1 ft = 0.3048 m.

RURAL TELECOMMUNICATIONS CONSTRUCTION PRACTICES
 NETWORK INTERFACE DEVICE (NID) MOBILE HOME INSTALLATION
 WITHIN 35 FEET OF ELECTRIC SERVICE EQUIPMENT

Scale: NTS

March 2001

NID7

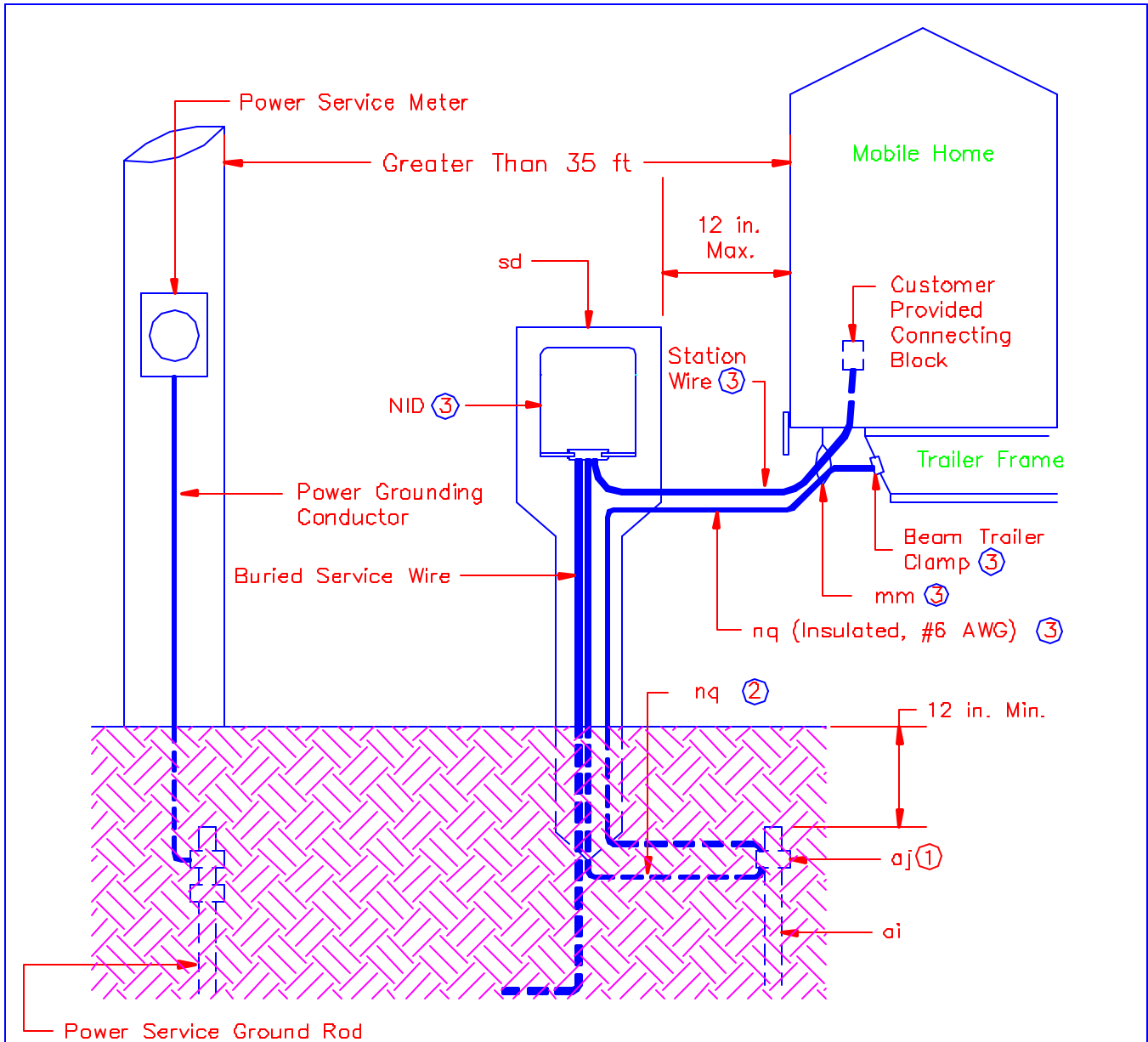

Notes:

- ① One clamp may be used if it is listed by Underwriter's Laboratories (UL) or other acceptable organizations for connecting two wires, otherwise two UL or other acceptable organization listed clamps must be used.
- ② The ground wire conductor size used shall be chosen for the installation based on the number of telco circuits to be installed at the customer location. See RUS Bulletin 1753F-801(PC-5A) for correct conductor size.
- ③ See RUS Bulletin 1753F-801(PC-5A) for terminations

ITEMS	NO.	REQ'D	MATERIALS	ITEMS	NO.	REQ'D	MATERIALS
NID	1		NID, outside station (specify no. of modular jacks/fuseless protectors)	*nq	as req'd		Wire, ground, insulated (See Note 2 for conductor size)
ai	1		Rod, ground, 1/2" x 5' 0" min.	*nq	as req'd		Wire, ground, insulated, #6 AWG copper
aj	1		Clamps, ground rod and pipe	sd	1		Post, mobile home
*mm	1		Drive ring	-	1		Clamp, trailer beam

For converting English units to metric units use
 1 in. = 25.4 mm and 1 ft = 0.3048 m.

RURAL TELECOMMUNICATIONS CONSTRUCTION PRACTICES
 NETWORK INTERFACE DEVICE (NID) MOBILE HOME INSTALLATION
 OVER 35 FEET FROM ELECTRIC SERVICE EQUIPMENT

Scale: NTS

March 2001

NID8

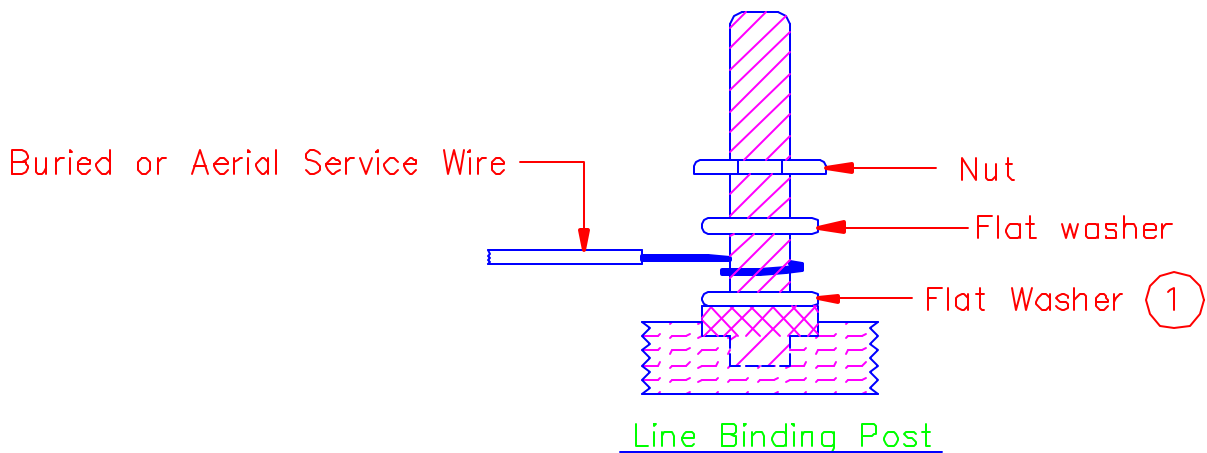
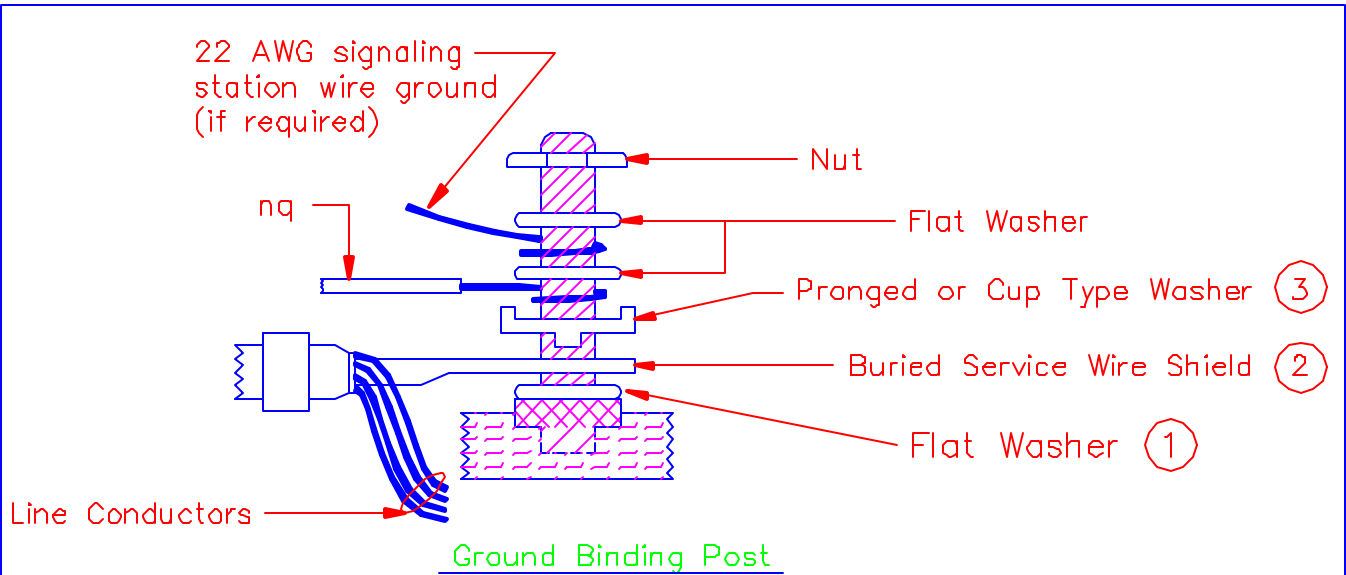

Notes:

- ①. If the shoulder is inadequate to support the shield or the conductor an additional flat washer shall be added. The first flat washer shall be placed on the shoulder. The first conductor (or terminal) shall be placed on the first flat washer.
- ②. Buried service wire shield shall be terminated on the station protector grounding lug of the NID using either Figure 12 of RUS Bulletin 1753F-801(PC-5A), shield bonding connector manufacturer's instructions, or Guide Drawing 963-2.
- ③. Station protector binding posts of NID may be equipped with a cup type washer instead of a pronged washer.

RURAL TELECOMMUNICATIONS CONSTRUCTION PRACTICES
 BURIED SERVICE WIRE TERMINATIONS OF SHIELD AND
 CONDUCTORS ON STATION PROTECTOR BINDING POSTS OF NID

Scale: NTS

March 2001

962-1

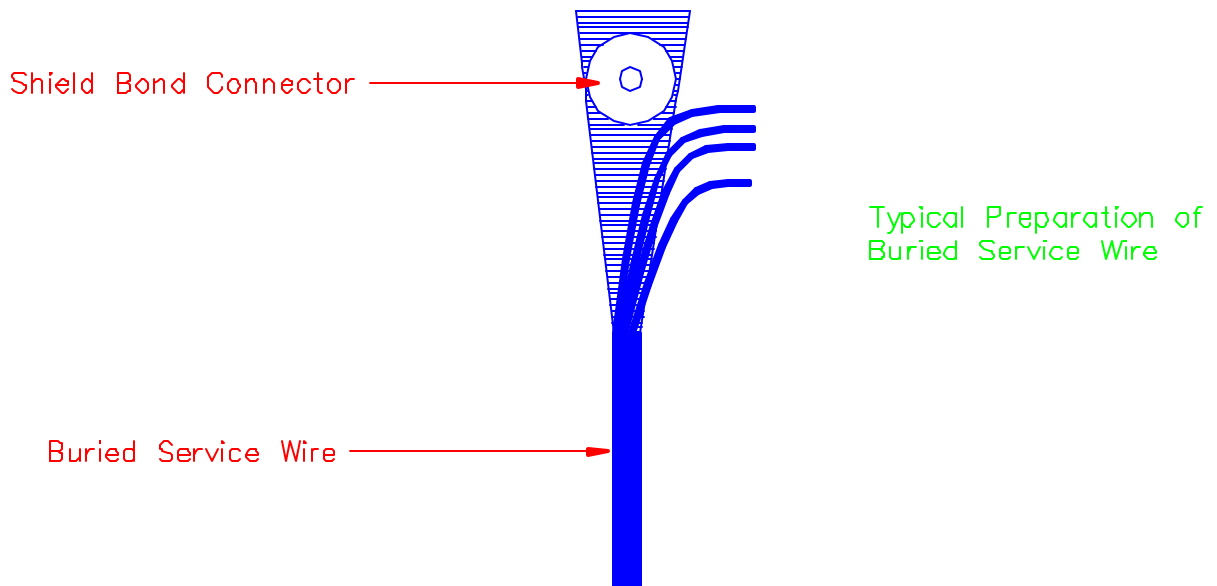
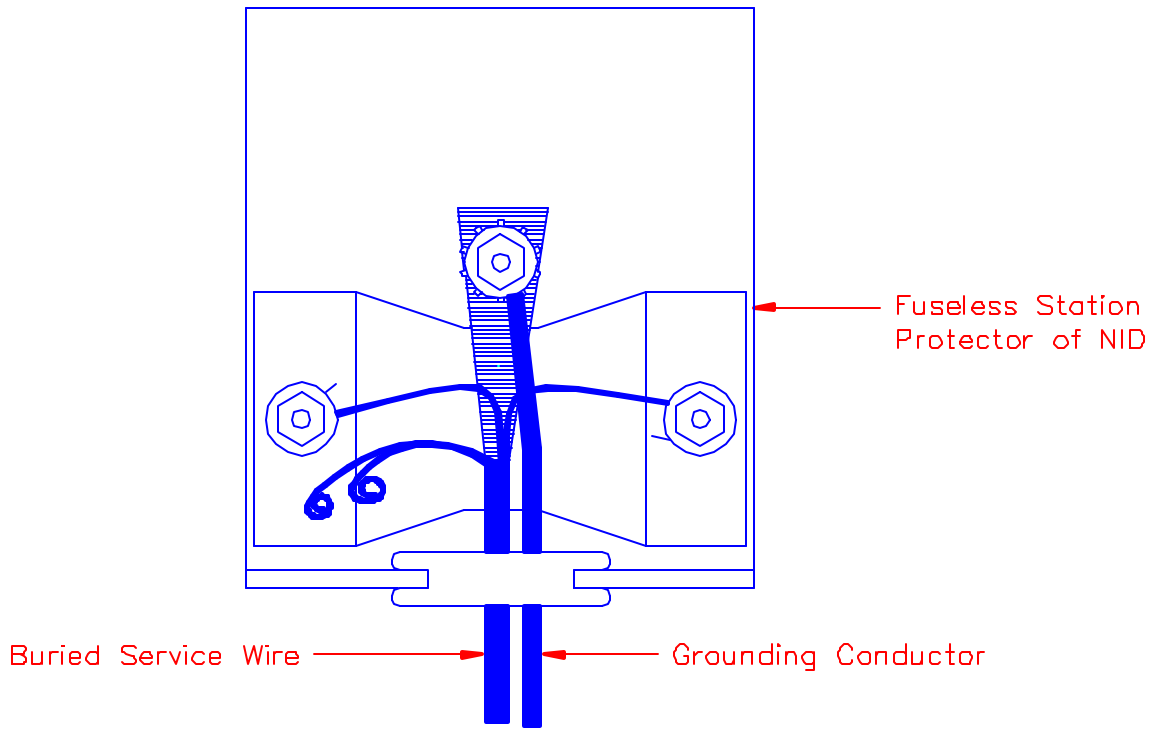

RURAL TELECOMMUNICATIONS CONSTRUCTION PRACTICES
 BONDING BURIED SERVICE WIRE AT STATION PROTECTOR
 OF NID USING SERVICE WIRE SHIELD BONDING CONNECTOR

Scale: NTS

March 2001

963-2