

UNITED STATES DEPARTMENT OF AGRICULTURE  
RURAL UTILITIES SERVICE

**BULLETIN 1724D-114**

**SUBJECT:** **Voltage Regulator Application on Rural Distribution Systems**

**TO:** RUS Electric Borrowers and RUS Electric Staff

**EFFECTIVE DATE:** Date of Approval.

**OFFICE OF PRIMARY INTEREST:** Electric Staff Division.

**INSTRUCTIONS:** This is a new bulletin.

**AVAILABILITY:** This bulletin is available on the Rural Utilities Service (RUS) website at:  
[www.rd.usda.gov/publications/regulations-guidelines/bulletins/electric](http://www.rd.usda.gov/publications/regulations-guidelines/bulletins/electric).

**PURPOSE:** This bulletin provides fundamental information about voltage regulators, their controls, and their application on rural distribution systems for Rural Utilities Service (RUS) borrowers and others.



Christopher A. McLean  
Acting Administrator, Rural Utilities Service  
Rural Development, U.S. Department of Agriculture

December 4, 2017

Date

1	INTRODUCTION .....	4
2	VOLTAGE STANDARDS.....	4
3	VOLTAGE REGULATION ON DISTRIBUTION SYSTEMS .....	6
4	VOLTAGE REGULATORS .....	9
5	SUBSTATION VOLTAGE REGULATORS AND SYSTEM VOLTAGE LEVELS .....	26
6	LINE VOLTAGE REGULATOR APPLICATION .....	32
7	VOLTAGE REGULATOR INSTALLATION .....	35
8	VOLTAGE REGULATOR AND CAPACITOR APPLICATIONS.....	36
9	VOLTAGE REGULATOR PROTECTION.....	42
10	REFERENCES .....	43

### Exhibits

Exhibit A – Derivation of Formulas for Calculating Voltage Drop and Voltage Regulation

Exhibit B – Effect of Shunt Capacitor on Source Current and Line Voltage

### INDEX:

Regulators (Voltage)  
Voltage Regulators  
Voltages (Distribution System)

### ABBREVIATIONS

AC	Alternating Current	LDC	Line Drop Compensator
ANSI	American National Standards Institute	LTC	Load Tap Changer
CFR	Code of Federal Regulations	PT	Potential Transformer
CT	Current Transformer	R	Resistance
EEPROM	Electrically Erasable and Programmable Read-Only Memory	RLC	Resistor-Inductor-Capacitor
IEEE	Institute of Electrical and Electronics Engineers	rms	Root Mean Square
kV	Kilovolt	RUS	Rural Utilities Service
kVA	Kilovolt-Ampere	SCADA	Supervisory Control and Data Acquisition
kvar	Kilovolt-Ampere Reactive	VD	Voltage Drop
		VR	Voltage Regulation
		VSC	Voltage Sensing Circuit
		X	Reactance

### DEFINITIONS

Bandwidth — The difference between the maximum and minimum allowable voltages within which a voltage regulator will hold the output voltage.

**Base Voltage** — Base voltage is a reference voltage value which is a common denominator to the nominal voltage ratings of transmission and distribution lines, transmission and distribution equipment, and utilization equipment. For example, the base voltage of a transmission line having a nominal voltage rating of 34,500 volts is 115 volts; the base voltage of a distribution line having a nominal voltage rating of 7,200 volts is 120 volts. In general, distribution lines and associated equipment having a nominal rating from 2,400 volts through 19,920 volts will have a 120-volt base, and the nominal voltage rating of utilization equipment served by these voltages will also have a 120-volt base.

**Maximum Voltage** — Maximum voltage is the greatest sustained five-minute mean or average voltage.

**Minimum Voltage** — Minimum voltage is the smallest sustained five-minute mean or average voltage.

**Nominal Voltage** — The nominal voltage of a circuit or system is a nominal value assigned to the circuit or system for the purpose of conveniently designating its voltage class. For example, the nominal rural residential voltage is 120 volts, although the voltage may actually range from 114 volts to 126 volts.

**Rated Voltage** — Rated voltage is the voltage at which performance and operating characteristics of utilization equipment are referred.

**Service Voltage** — Service voltage is the voltage at the point where the electric systems of the supplier and the user are connected. In rural electric systems, this is usually considered the voltage at the meter socket or service entrance switch.

**Utilization Equipment** — Utilization equipment refers to consumer electrical loads, such as electrical appliances, lighting fixtures, heaters, and motors.

**Utilization Voltage** — Utilization voltage is the voltage at the line terminals of utilization equipment. This is generally considered to be the voltage at the terminals of the device or appliance or the voltage at the convenience outlet to which these terminals are connected.

**Voltage Drop** — Voltage drop (in a supply system) is the difference between the voltages at the transmitting and receiving ends of a circuit, main, or service.

**Voltage Regulation** — Voltage regulation of a line is the percent voltage drop with respect to the receiving-end voltage.

**Voltage Spread** — Voltage spread is the difference between maximum and minimum voltage at a particular location in the distribution system.

## 1 INTRODUCTION

Providing acceptable voltage levels to consumers is vital to the proper operation of utilization equipment (i.e., electrical appliances, equipment, and other electrical loads). If utilization equipment is operated outside its prescribed voltage limits, equipment damage and erratic performance could result. An overvoltage condition, for example, can significantly shorten equipment life, decrease power factors of motors, and burn out lights and heating elements. On the other hand, an undervoltage condition can result in overheating of motors, dim lights, and cause other potential equipment damage. Hence, it is important for electric utilities to regulate their distribution system voltage for proper operation of electrical equipment.

It is impractical for electric utilities to provide each consumer with constant voltage that exactly matches the rated voltage of utilization equipment. Thus, the standard practice for utilities is to provide consumers with voltage levels that are within voltage ranges established by the American National Standards Institute (ANSI) and the Rural Utilities Service (RUS). To ensure that utilization voltage is kept within prescribed limits, electric utilities use voltage regulators on their distribution systems as a standard practice. This bulletin provides fundamental information about voltage regulators, their controls, and their application on rural distribution systems for RUS borrowers and others.

## 2 VOLTAGE STANDARDS

In many states, the limits of voltage spread permitted at consumers' meters are established by the state regulatory commissions. In states where borrowers are not subject to such controls, RUS recommends the limits established by the American National Standards Institute in ANSI C84.1-2016, "Electric Power Systems and Equipment—Voltage Ratings (60 Hertz)."

### a Nominal System Voltage Standards

Table 1 presents the nominal voltages for secondary circuits established in ANSI C84.1-2016 and is recommended by RUS for its borrowers to serve their residential and commercial consumers. The voltage limits established and recommended in ANSI C84.1-2016 are used by the majority of the electric utilities in the United States.

TABLE 1: Nominal Low-Voltage Standards.<sup>1</sup>

Nominal System Voltages	Connection and Phase
120-V	Two-wire, single-phase
120/240-V	Three-wire, single-phase
240/120-V	Four-wire, three-phase delta
208Y/120-V	Four-wire, three-phase wye
480Y/277-V	Four-wire, three-phase wye
480-V	Three-wire, three-phase delta

b ANSI Recommended Voltage Limits

ANSI Standard C84.1-2016 establishes voltage limits. The maximum and minimum utilization voltage limits for 120- to 480-volt circuits are shown in Table 2.

TABLE 2: ANSI Recommended Service and Utilization Voltage Ranges.<sup>1</sup>

Range	Nominal System Voltage (Volts)	Minimum		Maximum
		Utilization Voltage (Volts)	Service Voltage (Volts)	Utilization and Service Voltage (Volts)
A	120	108	114	126
A	120/240	108/216	114/228	126/252
A	240/120	216/108	228/114	252/126
A	208Y/120	187Y/108	197Y/114	218Y/126
A	480Y/277	432Y/249	456Y/263	504Y/291
A	480	432	456	504
B	120	104	110	127
B	120/240	104/208	110/220	127/254
B	240/120	208/104	220/110	254/127
B	208Y/120	180Y/104	191Y/110	220Y/127
B	480Y/277	416Y/240	440Y/254	508Y/293
B	480	416	440	508

As shown in Table 2, for any given nominal system voltage, the actual operating values can vary over various ranges of voltage limits. ANSI C84.1-2016 categorizes voltage ranges into Range A and Range B. Range A is bounded by voltage limits within which service voltages have to be held. Range A includes the majority of the existing utilization equipment operating voltages that produce satisfactory operation of consumer equipment. Range B is bounded by voltage limits that are slightly above and below the Range A voltage limits. In this range, consumer equipment may still operate satisfactorily, although its performance may be less than warranted by the manufacturer. Range B voltage limits can be tolerated for limited frequency and duration only.

c RUS Recommendations on Voltage Levels

RUS recommends that rural electric distribution systems be designed and operated to meet the voltage level requirements of Range A, per ANSI C84.1-2016, as presented in Table 2 of this Bulletin. The optimum utilization of voltage regulators as an integral part of the design and operation of the distribution system is the basic approach to meeting these requirements.

The effects of adopting Range A voltage limits on a rural distribution system result in voltage spreads shown in Tables 3 and 4 of this Bulletin. Table 3 shows

the voltage spreads and levels (on a 120-volt base) for a rural distribution line using a suitable voltage regulator with line drop compensation. Table 4 shows the voltage drops and percent voltage drops (on a 120-volt base) permitted in each segment of a rural distribution line.

TABLE 3: Allowable Voltage Levels for Rural Distribution System Design (120-Volt Base).<sup>2</sup>

Location on System	Voltage Levels	
	Minimum	Maximum
Substation Regulated Bus	118	126
<u>Distribution Transformer Primary Terminals</u>		
Closest to substation bus	118	126
At end of line	118	126
<u>Service Connection (Meter Socket)</u>		
First consumer off transformer closest to substation bus	114	126
Last consumer off transformer at end of line	114	126
<u>Point of Utilization</u>		
First consumer off transformer closest to substation bus	110	126
Last consumer off transformer at end of line	110	126

TABLE 4: Voltage Drops for Rural Distribution System Design (120-Volt Base).<sup>2</sup>

Section of Rural Distribution System	Voltage Drop (Volts)	Voltage Drop (%)
Substation Bus to End of Primary Distribution Line	8	6.67
Distribution Transformer and Service Conductors to Metering Point	4	3.33
Consumer's Service Point to Utilization Point		
Loads Include Lighting	4	3.33
Non-lighting Loads	6	5.00

### 3 VOLTAGE REGULATION ON DISTRIBUTION SYSTEMS

#### a Primary Distribution System

Table 5 shows the preferred nominal primary voltages for wye-connected electric distribution systems. These are the typical RUS distribution voltages.

TABLE 5: Preferred Nominal Distribution System Voltages.

Wye-Connected Systems (Volts)
12,470Y/7,200
13,200Y/7,620
24,940Y/14,400
34,500Y/19,920

b Voltage Regulation on a Distribution System

The maximum load of a primary distribution circuit is limited by the current-carrying capacity and voltage regulation of the circuit. Of these two factors, voltage regulation is more often the controlling factor. If not limited by the current-carrying capacity, the maximum load of the primary distribution circuit is determined by the maximum service voltage allowed at the first customer on the circuit and the minimum service voltage allowed at the last customer on the circuit during maximum load demand. The latter is known as a voltage constrained distribution circuit.

On rural distribution systems, voltage regulation of primary distribution circuits is normally accomplished using voltage regulators at distribution substations and on distribution lines. Capacitors are applied both at substations and on distribution lines, in conjunction with voltage regulators, to obtain the maximum economic benefits in improving voltage regulation of the lines. However, capacitors cannot replace circuit voltage regulators in maintaining constant voltage at the service point. For voltage control, shunt capacitors are useful in boosting the line voltage only, whereas voltage regulators automatically adjust line voltage to within prescribed voltage limits as load conditions vary.

(1) Voltage Spread. The range of voltage variation allowable at a strategic point of a distribution system is referred to as the voltage spread. In general, the strategic points in a distribution system where voltages are allowed to vary within designated voltage spreads are: (1) substation bus, (2) primary terminals of distribution transformers, (3) service points (service entrance) of consumers, and (4) utilization points (e.g., outlets) at consumers' premises. The voltage spread at the consumer service point is important to the overall design and operation of a distribution system.

(2) Voltage Drop and Regulation

Voltage drop is an important element in distribution circuit design. Maintenance of adequate voltage levels throughout a distribution circuit requires holding voltage drops on sections of the circuit to within acceptable limits as described in [Table 4](#) of this Bulletin. By definition, voltage drop is the difference between the voltages at the sending and receiving ends of a feeder, main, or service.<sup>3</sup>

Voltage regulation is a measure of performance of a distribution circuit with respect to voltage drop. The voltage regulation of a distribution circuit is the ratio of the voltage drop of the line to the load voltage which can be presented in percent regulation. The formulation for calculating voltage drop and voltage regulation of a simple circuit is presented in [Appendix A](#).

(3) Voltage-Limited Distribution Circuit Design

The primary considerations in designing a voltage-constrained distribution circuit are the allocated voltage drops and voltage spreads at strategic points of the circuit for the first and last consumers. The aggregate voltage drop between the substation bus and the first or last consumer includes voltage drops in the primary circuit, distribution transformer, secondary circuit, and service point. As shown in Table 4 of this Bulletin, the allocated voltage drops allow a 12-volt or 10% voltage drop maximum between the regulated bus and service point of the last consumer on the circuit. Since the voltage drop from the substation bus to the service point of the last consumer is at maximum, the primary design consideration is to maintain a service voltage no less than the minimum limit of 114 volts. On the other hand, due to the minimal voltage drop between the substation bus and the service point of the first consumer, the primary design consideration is to maintain a service voltage no more than the allowed maximum limit of 126 volts.

Due to variation in loads, load swings between peak and light load conditions are important considerations in a voltage-constrained design of a distribution circuit. The last consumer on the circuit is most affected by voltage swing. It is important that the voltage change or spread is limited to the allowed value. As shown in Table 3 of this Bulletin, the maximum voltage spread recommended by RUS for consumers to experience is 8 volts at the consumer's service point.

In addition to voltage drop and voltage spread considerations, the following points have to be considered in designing a voltage-constrained distribution circuit.

- (a) There are several methods for improving voltage levels on a distribution circuit other than the use of voltage regulators. The following voltage level improvement methods should also be examined for feasibility and economics.
- (1) Construction or extension of express feeders (that serve no transformers or tapped transformers along their route) to the circuit's load center or first service transformer,
  - (2) Converting single-phase lateral branch circuits to three-phase circuits,
  - (3) Reconductoring of circuits using larger conductors,
  - (4) Rearrangement of circuits,
  - (5) Balancing loads (taps and/or transformer connections) on three-phase lines,
  - (6) Installation of capacitors,
  - (7) Construction of new substation or distribution feeders, and



- (8) Converting to a higher distribution voltage.
- (b) The voltage range of substation voltage regulators is limited by the allowable primary voltage levels of the first distribution transformer.
- (c) Distribution circuits have to be designed to maintain acceptable voltage levels per ANSI C84.1-2016. Future load growth also has to be taken into consideration.
- (d) The allocation of voltage drops between the primary circuits, distribution transformers, secondaries, and services have to be optimized with the over-all cost.

#### 4 VOLTAGE REGULATORS

Voltage regulators are the most commonly used regulating equipment on distribution systems. The function of a voltage regulator is to measure the line voltage and automatically adjust the voltage to a preset level. Voltage regulators are effective in automatically correcting high-voltage and low-voltage conditions. They are simple to apply and they provide voltage correction, within close tolerances, needed to maintain desired voltage levels.

- a Types of Voltage Regulators. There are two general types of voltage regulators: (1) induction-voltage regulators and (2) step-voltage regulators. For all practical purposes, the induction-voltage regulator has been replaced by the modern step-voltage regulator. Hence, the following discussion will focus only on step-voltage regulators.

- (1) Step-Voltage Regulators

A step-voltage regulator is “a voltage regulator in which the voltage and (or) phase angle of the regulated circuit are controlled in steps by means of taps without interrupting the load.”<sup>4</sup> There are two types of step-voltage regulators as defined by the ANSI: (1) Type A, also known as “straight” design, and (2) Type B, also known as “inverted” design. Schematic diagrams of Type A and Type B step-voltage regulators are shown in Figures 1 and 2, respectively, of this Bulletin.

- (a) In a Type A step-voltage regulator, the primary circuit (source side) is directly connected to the shunt winding of the regulator (Figure 1). The symbol “S” represents the source-side terminal of the voltage regulator. The shunt winding is connected to the series winding via a reversing switch. The other end of the shunt winding is connected to ground or common conductor at terminal “SL.” With the reversing switch, the polarity of the induced

voltage across the series winding (secondary voltage) can be reversed with respect to the polarity of the shunt winding voltage, allowing the secondary voltage to be subtracted from or added to the primary voltage.

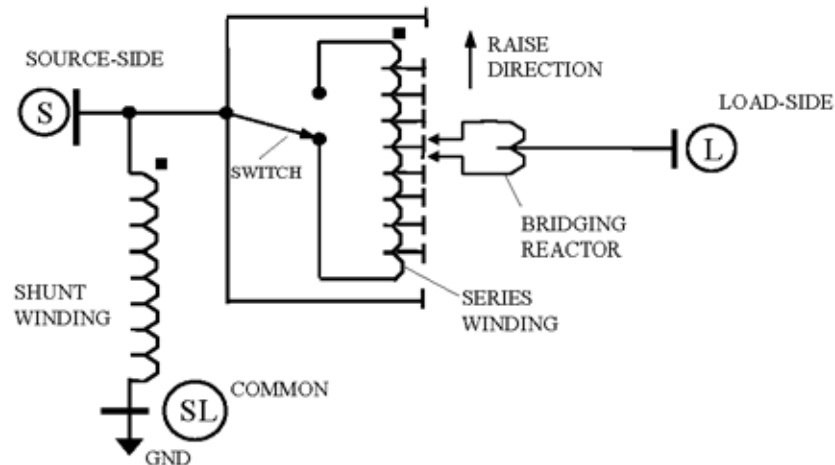

FIGURE 1: Schematic Diagram of a Single-Phase, Type A Step-Voltage Regulator.

In essence, the reversing switch allows the regulator to switch between buck and boost positions. The series winding, in turn, is connected to the regulated circuit, at terminal “L,” via an automatic tap-changing mechanism, composed of multiple taps, “two-finger” contacts, and bridging reactor, also known as preventive auto-transformer. The multiple taps allow the raising and lowering of line voltage by increments or steps without interrupting consumers’ loads. Load interruption is prevented by using “two-finger” contacts which are separated in a manner that both “fingers” cannot break contact at the same time when changing taps. The function of the bridging reactor is to prevent a short-circuit condition when both “fingers” are in contact with different taps or in bridging position. In a Type A step-voltage regulator, the core excitation varies because the shunt winding is connected across the primary circuit.

- (b) In a Type B step-voltage regulator, shown in Figure 2, the primary circuit from source side is connected, via a bridging reactor and taps, to the series winding of the regulator. The series winding in turn is connected to the shunt winding through a reversing switch. The functions of the components of a Type B step-voltage regulator are similar to those of Type A. However, in a Type B

step-voltage regulator, the core excitation is constant because the shunt winding is connected across the regulated circuit.

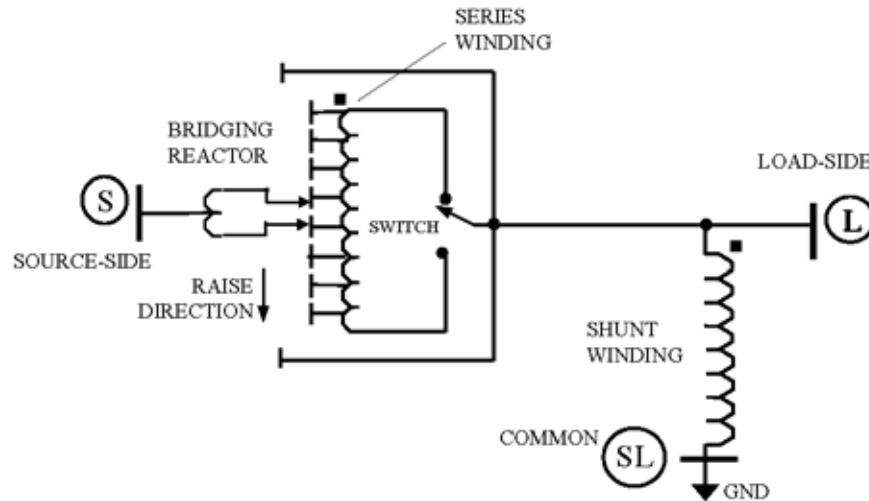

FIGURE 2: Schematic Diagram of a Single-Phase, Type B Step-Voltage Regulator.

(2) 32-Step Voltage Regulator

- (a) Step voltage regulators are available as 32-step voltage regulators and 4-step voltage regulators. The 32-step voltage regulator is the most commonly used regulator on distribution systems in the United States. The application of 4-step voltage regulators on rural distribution systems is very rare. As a general rule, the 4-step voltage regulator is not used in substations. A 4-step regulator is designed to be used on a tap line when no special coordination is required with the upstream 32-step voltage regulator that is used to regulate the main feeder. For brevity purposes, only the 32-step voltage regulator is discussed in this bulletin.
- (b) Most substation and downline step-voltage regulators are designed to correct bus or line voltage from 10% boost to 10% buck (i.e.,  $\pm 10\%$ ) in 32 steps. These regulators are generally known as 32-step voltage regulators. The 32-step voltage regulator can be an ANSI Type A or Type B step-voltage regulator. As shown in Figures 1 and 2 of this Bulletin, the series winding of a 32-step voltage regulator has 8 taps. However, because of the reversing switch that allows the regulator to switch between boost and buck positions, the effective number of taps is 16. As the “fingers” of

the contact mechanism of the bridging reactor move up and down the series winding, they alternately rest on the same contact (Figure 1) and in bridging position (Figure 2). These dual contact positions result in a total of 32 steps. Since the full voltage regulation range is 20%, each step, therefore, represents a 5/8% voltage change.

- (c) To perform automatic voltage control, the 32-step voltage regulator is equipped with voltage control circuit. The voltage controller allows the regulator to sense voltage changes on the substation bus or distribution line and adjust the voltage output accordingly by automatically changing the regulator's taps. Modern step-voltage regulators are equipped with communications terminals for remote control options, either through a supervisory control and data acquisition (SCADA) system or via direct dialing.

b General Description

(1) KVA Rating

In selecting the proper step-voltage regulator for a specific application, the required kVA rating has to be determined and, to determine the kVA rating of a regulator, the following information has to be known:

- Type of bus or circuit connection (D or U connection) and whether single- or three-phase voltage regulators will be used,
- Voltage rating of bus or distribution feeder,
- Continuous load current or kVA rating of bus or distribution feeder, and
- Amount of voltage correction required.

The kilovolt-amperes (kVA) rating of a single-phase, step-voltage regulator is the product of the continuous load current and the rated "raise" or "lower" voltage regulation range in kilovolts (kV), as expressed by the following formula:

$$\text{Rated kVA} = \text{Continuous Load Current} \\ (\text{in Amps}) \times \text{Regulation Range (in kV)}$$

For example, the kVA rating of a 10%, single-phase voltage regulator required to supply a load rated at 100 amperes on a 7,620-volt line-to-ground single-phase circuit would be:

$$\text{Rated kVA} = 100 \text{ A} \times (0.10 \times 7.620 \text{ kV}) = 76.2 \text{ kVA}$$

Note that, if the rated current is not directly known and the kVA rating of the circuit is known, then the rated current can be calculated as follows:

$$\text{Rated Current} = \frac{\text{Rated kVA}}{\text{Rated kV (line-ground)}}$$

for a single-phase circuit, or

$$\text{Rated Current} = \frac{\text{Rated kVA}}{\{1.732 \times \text{Rated kV (line-line)}\}}$$

for a three-phase circuit.

For a 10% single-phase, delta-rated, step-voltage regulator supplying a load rated at 100 amperes through a 13,800-volt, phase-to-phase distribution system, the kVA rating of the voltage regulator would be:

$$\text{Rated kVA} = 100 \text{ A} \times (0.10 \times 13.8 \text{ kV}) = 138 \text{ kVA}$$

For three-phase step-voltage regulators, the kVA ratings are determined in similar manner as the kVA ratings of single-phase step-voltage regulators. The kVA rating of a three-phase step-voltage regulator is the product of the rated load current and the rated range of regulation in kilovolts (kV) multiplied by 1.732. Three-phase voltage regulators can be applied either to three-phase/three-wire or three-phase/four-wire circuits.

In cases where the ranges of regulation are different for the “raise” range and the “lower” range, the larger percent regulation is used in determining the regulator kVA rating. The preferred kVA ratings for step-voltage regulators are based on operation at a frequency of 60 Hz and a voltage range of 10% raise and 10% lower. In addition to the preferred kVA ratings, step-voltage regulators have to deliver rated kVA output without exceeding the temperature rise at the given operating voltage per ANSI C57.15-1986.

(2) Extended Range of Ratings

One of the inherent features of a step-voltage regulator is that regulator losses decrease as the regulator moves from the extreme tap positions (boost or buck) closer to the neutral point. As a result, the range of voltage regulation required need not always be a full  $\pm 10\%$ . This allows for an extended range of regulator operation.

In instances where less than the full 10% regulation is needed, the load-carrying capabilities of the step-voltage regulator can be extended. Single-phase, step-voltage regulators with rated voltage up to 19.92 kV and rated current at 668 A and below have extended continuous current

ratings on intermediate ranges of steps as shown in Table 6 in this Bulletin, not to exceed 668A.

TABLE 6: Recommended Continuous-Current Ratings on Intermediate Steps of Voltage Regulation for 19.92 kV and Below Single-Phase Step-Voltage Regulators.<sup>4</sup>

<b>Range of Voltage Regulation (Percent)</b>	<b>Continuous-Current Rating (Percent)</b>
± 10.00 %	100 %
± 8.75 %	110 %
± 7.50 %	120 %
± 6.25 %	135 %
± 5.00 %	160 %

Three-phase, step-voltage regulators with rated voltage up to 13.8 kV and rated current at 668 A and below have extended continuous current ratings on intermediate ranges of steps as shown in Table 7 in this Bulletin, not to exceed 668 A.

TABLE 7: Recommended Continuous-Current Ratings on Intermediate Steps of Voltage Regulation for 13.8 kV and Below Three-Phase Step-Voltage Regulators<sup>4</sup>

<b>Range of Voltage Regulation (Percent)</b>	<b>Continuous-Current Rating (Percent)</b>
±10.00 %	100 %
± 8.75 %	108 %
± 7.50 %	115 %
± 6.25 %	120 %
± 5.00 %	130 %

It can be seen from Tables 6 and 7 that step-voltage regulators can extend their continuous-current rating up to a maximum rating of 668 A when set below 10% voltage regulation. For example, the continuous-current rating of a 7.62-kV single-phase voltage regulator rated at 438 A and set at ±5.00% voltage regulation will raise its loading capability to 668 A.

Due to the increased loading capability or “load bonus” of voltage regulators, investment cost can be reduced by using lower-rated regulators. However, before taking this approach, care has to be taken to ensure that opportunity for future load growth, flexibility under sudden load changes, and proper voltage regulation in cases of emergency are considered.

(3) Terminal Designations

The terminal designations of single-phase and three-phase step-voltage regulators are shown in Figure 3 in this Bulletin. For single-phase step-voltage regulators, the terminal connected to the load is designated L, the terminal connected to the source is designated S, and the common terminal is designated SL. For three-phase step-voltage regulators, these identifications are S1, S2, S3, L1, L2, L3, and S<sub>0</sub>L<sub>0</sub>.

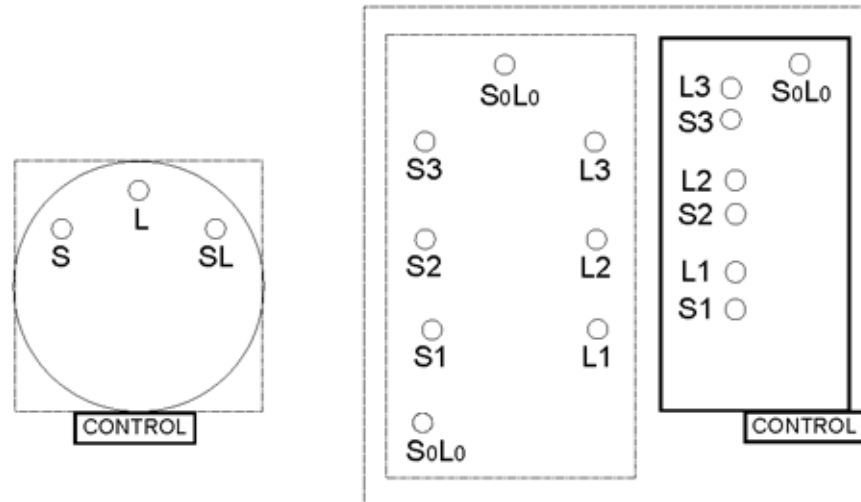

Single-Phase Step-Voltage Regulator

Three-Phase Step-Voltage Regulator

FIGURE 3: Step-Voltage Regulator Terminal Designations.

(4) Regulator Standards

Regulators for use on RUS borrowers' systems have to comply with the requirements of ANSI C57.15-2009, "IEEE Standard Requirements, Terminology, and Test Code for Step-Voltage and Induction-Voltage Regulators."

(5) Short-Circuit Requirements

Step-voltage regulators used on RUS borrowers' systems must be designed and constructed to withstand root-mean-square (rms) symmetrical short-circuit currents of 25 times the regulator full-load currents for 2 seconds and 40 times the regulator full-load current for 0.8 seconds without damage.<sup>4</sup>

Voltage regulators, especially those installed at substations, are subjected to high short-circuit requirements. Care must be exercised in regulator applications to ensure that the short-circuit capabilities of the regulator are

not exceeded. The following procedure must be observed in applying regulators on a rural distribution system.

- (a) Determine the short-circuit duty at the proposed location in terms of available fault current and clearing time of the over-current protective device, and
- (b) If the short-circuit duty on the regulator exceeds its capabilities, then one of the following steps must be taken:
  - (1) Install a larger voltage regulator to obtain greater short-circuit withstand capabilities,
  - (2) Install the voltage regulator at a distance far enough from the substation to limit the duty at the regulator to safe values, or
  - (3) Install current limiting reactors at the substation to limit the available fault current.

c Step-Voltage Regulator Control

- (1) Basic Control Operations. In order to automatically and continuously correct bus and circuit voltages according to pre-determined voltage levels, step-voltage regulators are equipped with automatic controls. In general, the automatic control operation of a step-voltage regulator involves: (1) voltage-sensing, (2) switching and time delay, and (3) driving tap-changing motor. These control functions are accomplished with the control components shown in Figure 4.

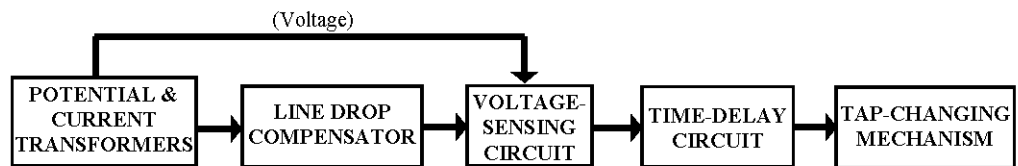

FIGURE 4: Step-Voltage Regulator Control Components.

- (2) Potential and Current Transformers. A potential transformer (PT) is installed at the output of the step-voltage regulator (L terminal). The PT steps down the actual line voltage to a 120-volt base voltage. The reduced voltage at the output of the PT is fed to the line drop compensator (LDC) and to the voltage-sensing circuit (VSC). The current transformer (CT) is typically internal to the step voltage regulator. It is a toroid through which the load current passes. It provides a source of current proportional to load current for line-drop compensation calculation and metering functions.



(3) Line Drop Compensator

- (a) When a step-voltage regulator is used to regulate the voltage of a load center located at some distance, the load cannot be served at the desired voltage level due to the line losses between the regulator and the load. As the load increases, line losses also increase, causing lowest voltage condition during heaviest loading. This means consumers at the end or near the end of the line could experience undervoltage at times when the distribution system is heavily loaded.
- (b) A line drop compensator (LDC) is incorporated in the regulator controls in order for the voltage regulator to maintain a constant voltage at a “projected” point on a distribution line. The LDC circuit is composed of a CT and adjustable resistive and reactive elements. The resulting CT current is passed through the resistive and reactive elements and produces voltage drops that simulate the voltage drops on the primary line between the regulator and the regulated point down line. Hence, LDC allows the voltage regulator to extend its voltage regulation capability to a distant part of the distribution line. When properly applied, the LDC can distribute the voltage variations equally between the first and last customer on the distribution feeder.
- (c) The LDC circuit is connected with the PT such that the simulated LDC voltage drop is vectorially subtracted from the PT voltage. The resultant voltage is then fed to the VSC. A simplified diagram of the LDC and VSC connection is shown in Figure 5.

**Sub. Bus**

FIGURE 5: Simple Schematic Diagram of LDC and VSC.

- (4) Setting of Line Drop Compensator. The voltage boost produced by a line drop compensator (LDC) is a function of the settings of the resistance,  $R$ , and reactance,  $X$ , controls on the control panel and of the amount of the line current flowing through the regulator. The LDC settings are

accomplished at the control panel by means of the R and X dials. In modern regulator controls, the R and X voltage settings are adjusted by pressing the corresponding LDC function codes on a keypad on the control panel. The R and X voltage settings have to correspond to the amount of resistive and reactive voltage drops expected on the distribution circuit at peak load condition. There are several methods for determining the proper setting of load drop compensators. Some of these methods are discussed below.

(a) Traditional LDC Setting Method

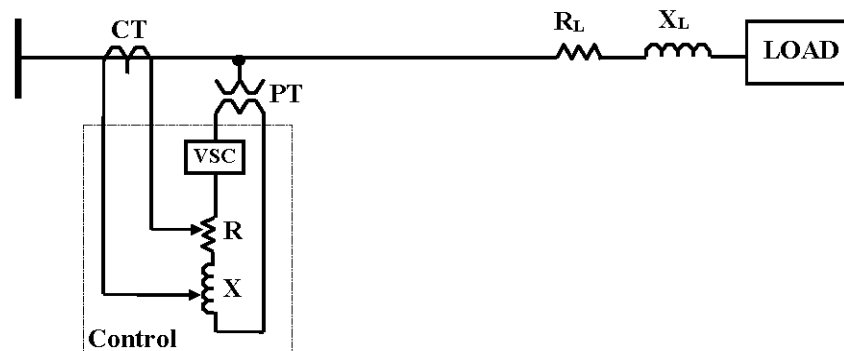
Traditionally, the LDC settings are set to produce a 4-volt rise above the 122-volt set voltage during the annual peak load. To attain the 4-volt rise, the R and X control settings have to be such that R and X voltage values vectorially add up to 4 volts when the load current is equal to the current rating of the voltage regulator. In most cases, it is desirable to maintain a ratio between the R and X control settings equal to the R/X ratio of the actual distribution line. Although this ratio varies with the size and type of conductors used, for most distribution circuits a 5/3 ratio is satisfactory for copper conductors and most small non-copper conductors. Breaking down the 4 volts vectorially on this basis results to approximately 3.5 volts for R and 2 volts for X. These are the recommended R and X control settings if the annual peak load current is equal to the current rating of the regulator. Since the annual peak load current is not often equal to the regulator's current rating, it is necessary to calculate the R and X set values for the estimated peak current. This is done in the following steps:

- (1) Determine the current rating of the regulator. This is shown on the voltage regulator nameplate as the current transformer primary rating.
- (2) Estimate the peak load current expected during a time period between adjustments of voltage regulator controls. Regulator control adjustments are typically completed annually, but could be shortened to semi-annually or quarterly when there is a significant increase in seasonal peak demand or the load is increasing rapidly.
- (3) Divide the current rating by the peak load current. Multiply the result by 3.5 to obtain the R setting and by 2 to obtain the X setting. For example, if the voltage regulator rating is 150 A and the estimated peak current of the line is 80 A, the R and X settings can be estimated as follows:

$$K = 150 \text{ A} \div 80 \text{ A} = 1.87$$

$$R_{\text{SET}} = 3.5 \times K = 6.6 \text{ volts}$$

$$X_{\text{SET}} = 2 \times K = 3.75 \text{ volts @4 volts}$$

(Note: X setting is adjustable in 1-volt step only.)

(b) Load Center LDC Setting Method

When it is desired to hold a constant voltage at some specific spot on a distribution line (such as at a small town or industrial load), the R and X settings are based on the actual resistance and inductance of the distribution line between the voltage regulator and projected load center. In this case, the determination of the R and X settings is achieved by observing the following steps.

- (1) Calculate the R and X values of the distribution line by multiplying the per mile resistance and inductive reactance values by the actual line distance between the voltage regulator and load center.
- (2) From the nameplate of the voltage regulator, determine the current transformer primary rating and potential transformer ratio.
- (3) Calculate the R and X voltage values using the following equations:

$$R_{\text{SET}} = (CT_{\text{R}}/N_{\text{PT}}) \times R_{\text{L}} \text{ (volts)}$$

$$X_{\text{SET}} = (CT_{\text{R}}/N_{\text{PT}}) \times X_{\text{L}} \text{ (volts)}$$

Where:

$R_{\text{SET}}$  = R voltage setting (dial or function code), in volts

$X_{\text{SET}}$  = X voltage setting (dial or function code), in volts

$CT_{\text{R}}$  = Current transformer's primary current rating, in amperes

$N_{\text{PT}}$  = Power transformer turns ratio,  $V_{\text{PRI}}/V_{\text{SEC}}$

$R_{\text{L}}$  = Effective resistance of a feeder conductor from regulator to regulation point or load center

$X_{\text{L}}$  = Effective reactance of a feeder conductor from regulator to regulation point

For example, if the distance between the regulator and the load is 6.2 miles on a No. 2 copper equivalent line, the current transformer

primary rating is 150 A, and the potential transformer ratio is 60:1, the R and X settings can be calculated as follows:

$$R \text{ per mile for No. 2 copper} = 0.885 \text{ ohm/mile}$$

$$X \text{ per mile for No. 2 copper} = 0.756 \text{ ohm/mile}$$

$$R_L = 0.885 \text{ ohm/mile} \times 6.2 \text{ miles} = 5.5 \text{ ohms}$$

$$X_L = 0.756 \text{ ohm/mile} \times 6.2 \text{ miles} = 4.7 \text{ ohms}$$

$$R_{SET} = (CT_R/N_{PT}) \times R_L = (150 \text{ A}/60) \times 5.5 \text{ ohms} = 13.7 \text{ volts}$$

$$X_{SET} = (CT_R/N_{PT}) \times X_L = (150 \text{ A}/60) \times 4.7 \text{ ohms} = 11.8 \text{ volts}$$

(Note: This method is only applicable when the regulator solely serves the line for which the calculations are made. It cannot be used for setting substation regulators serving more than one circuit.)

(c) Voltmeter LDC Setting Method

The voltmeter method is a simple method for determining R and X settings of the LDC when the load on the regulator is at or very near the anticipated peak. The determination of the R and X settings is achieved by observing the following steps.

- (1) With the R and X values set at zero, connect an accurate voltmeter to the voltage test terminals of the control panel of the voltage regulator. Verify that the output voltage is 122 volts.
- (2) Slowly raise the R and X control settings (approximately in 5:3 ratio) until the voltmeter reads 126 volts.

With proper care, this method may be used with less than peak load on the regulator if the ratio of present load to peak load is known. For example, if the present load is one-half of the anticipated peak load, the R and X values have to be set to display a voltmeter reading of 124 volts, which is a boost of 2 volts or one-half the desired peak load boost of 4 volts.

- (5) Voltage-Sensing Circuit. The voltage-sensing circuit (VSC) provides a reference standard for the regulator voltage control. The VSC receives the resultant voltage from LDC and power transformer (PT) to determine if the voltage is beyond the VSC's preset limits. If the resultant voltage is higher or lower than the preset voltage limits, the VSC then sends a signal to a time-delay circuit which activates the operation of a timer. The timer

provides a time delay between the VSC action and the actual tap changing action. In essence, the VSC controls the motor-operated switching mechanism that selects the proper tap to “raise” or “lower” regulator output voltage through the action of the timer. There are two settings that are critical to the proper operation of VSC: (1) Set Voltage and (2) Bandwidth.

(a) Set Voltage

- (1) The set voltage is the voltage level to which the regulator control will regulate on the 120-volt base. It is this voltage with which all other voltages on the system are compared. The set voltage has to be as close to the ideal system voltage as possible. VSC can generally be set from 105 volts to 135 volts in one-volt increments. Generally, the voltage setting is based on the voltage limits delivered to the consumer’s meter, which is 114 volts to 126 volts as set forth in the ANSI Standards.
- (2) Selecting the mid-point of this range, 122 volts, would essentially provide every consumer downline the appropriate voltage service at light loads. Since line current is minimum at this operating condition, the voltage drop is also minimal on the line. The ideal set voltage value, therefore, is 122 volts. In some instances where LDC is not used, the set voltage may be held at 125 volts with a  $\pm 1$ -volt bandwidth.
- (3) The voltage sensing circuit (VSC) receives the resultant voltage of the LDC and PT outputs. If the resultant voltage received by the VSC is 4 volts less than the set value of 122 volts, for example, the VSC reacts accordingly and initiates tap changing actions of the regulator until the 122-volt set voltage is sensed. The tap changing action will, therefore, result in an actual regulator output of 126 volts.

(b) Bandwidth

- (1) The sensitivity or voltage tolerance of the VSC is known as the bandwidth. The bandwidth is the area above and below the set voltage level (e.g., 122 volts) within which the regulated voltage may fluctuate. It is the difference between the maximum and minimum allowable voltages in the regulator control. As an example, a 2-volt bandwidth on a 122-volt setting means the time-delay circuit will not activate the operational timer (time delay) until the voltage is below 121 volts or above 123 volts.

- (2) The selection of a narrow bandwidth will cause more tap changes to occur, but will provide a more tightly regulated line. Conversely, a wider bandwidth results in fewer tap changes, but at the expense of better regulation. Selection of the bandwidth settings has to be made recognizing the trade-off between better regulation and longer equipment life. The recommended bandwidth for RUS borrowers is 1.5 volts ( $\pm 3/4$  volt) or 2 volts ( $\pm 1$  volt).
- (6) Time Delay Circuit. The primary function of the time-delay circuit in the regulator control is to interject a preset “waiting period” or time delay into the tap-changing operation of the regulator. The time-delay circuit has a relay that activates the tap-changing mechanism after the time delay period expires. The preset time delay prevents the voltage regulator from responding to momentary voltage excursions that are outside the bandwidth limits. Responding to every momentary voltage flicker would result in significant life reduction of the tap-changing mechanism.
- (a) Time Delay Setting
    - (1) The time delay relay, set in the control panel, provides a predetermined response time for the regulator. When two voltage regulators are used on a circuit, their time delays have to be coordinated such that the substation voltage regulator operates first before the downstream regulator. This time delay coordination strategy allows the substation regulator to respond to changes before the line regulator and prevent unnecessary corrective actions by the line regulator. As a general rule, the time delay setting for substation regulators is 30 to 40 seconds. If excessive regulator operations are encountered, the setting may be readjusted up to 60 seconds, maximum.
    - (2) The time delay for line regulators has to be longer than that for substation regulators. Generally, the time delay of a line voltage regulator has to be longer by at least 15 seconds than that of the substation voltage regulator. By coordinating the time delay in this manner, the substation regulators are allowed to correct source voltage variations before line regulators operate. When more than one line regulator is used ([see the last paragraph of Section 6a of this Bulletin](#)), the time delay setting of the voltage regulator farthest from the substation has to be the highest.
  - (b) Bandwidth vs. Time Delay Settings

- (1) The number of tap changing operations which a regulator performs has a bearing on both the life of the regulator and on the interval between scheduled inspection and maintenance. The number of operations which a regulator will make during a given period is determined by the characteristics of the supply voltage and the load, and by the bandwidth and time delay settings of the regulator. A regulator operated under typical conditions will probably make, on the average, 100 to 200 tap changes per day. If the daily average number of operations falls much below 100, the regulator is possibly not used effectively. If the average tap changes per day are more than 200, additional maintenance service on the regulator would be required.
- (2) An increase in time delay or bandwidth will tend to reduce the number of regulator operations. Of the two approaches, increasing time delay reduces the number of tap-changing operations with the least sacrifice in voltage control. Examples of these approaches are shown in Figure 6.

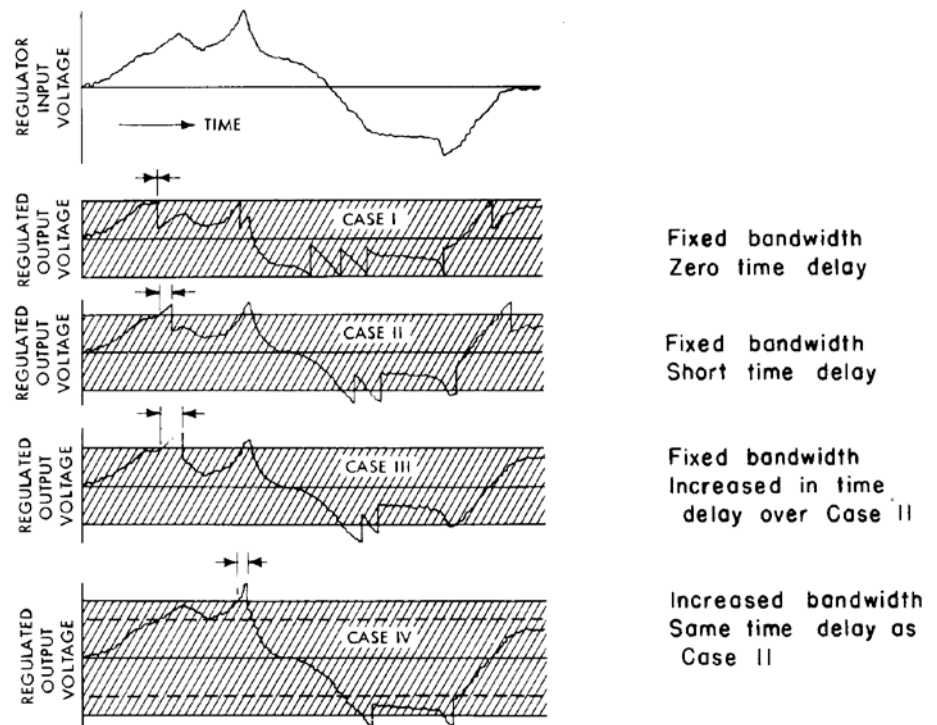

FIGURE 6: Effects of Time Delay and Bandwidth Settings on Voltage Regulator Output

- (3) As shown in Figure 6, the graph of the regulated output voltage for Case I (fixed bandwidth with zero time delay) depicts seven

tap-changing operations. Note that each tap-changing operation is characterized by an abrupt drop in voltage level.

- (4) As can be seen with Cases II and III, the number of tap-changing operations decreases as the time delay settings increase. Case IV shows that the number of regulator operations can be decreased by increasing the bandwidth. However, by increasing the bandwidth as clearly shown in the Case IV graph, voltage limits can be violated without being detected and corrected. Hence, the voltage quality is sacrificed in favor of reducing regulator operations.

(7) Range of Regulation Setting

- (a) The voltage regulation range is set at the regulator position indicator, which is generally mounted on the regulator tank. Setting is accomplished by adjusting the limit switches which stop the travel of the tap changer in either direction. These limit switches are located in the position indicator of the regulator, and their adjustments to provide the desired range of regulation is a simple matter (differing somewhat among the different brands of regulators).
- (b) At nameplate rating, a regulator will deliver rated current while either boosting or bucking the incoming voltage 10%. Reducing this regulation range, say 5%, will allow the regulator to carry more than the rated current. This extended range of load carrying capability at reduced regulation can play an important role in selecting the size of a voltage regulator to be used in a particular application.

(8) Tap-Changing Mechanism

- (a) When the load voltage goes out-of-band, the time delay circuit is activated. At the end of the time delay (e.g., 30 seconds), the output signal of the time delay circuit is relayed to the tap-changing mechanism, which, in turn, raises or lowers the tap by one step. After a tap change, a time period or pause is provided before the operational timer is reset. The pause, which is typically a duration of 2 seconds, allows the regulator control to sample the load voltage and determine if it is already in-band or still out-of-band. If the load voltage is in-band, as a result of the tap change, the operational timer is reset. If the load voltage is still out-of-band, a control signal is relayed to the tap-changing mechanism to perform another tap change. The sequence is continued until the load voltage is in-band.
- (b) There are two types of tap changers: spring-drive and direct-drive. For low-current applications, stored-energy spring-drive tap changers



are commonly used. Spring-drive tap changers are equipped with capacitor-run, reversing gear-motor suitable for operation at 120 V ac, single-phase, 60 Hz. For medium- and high-current applications, direct motor-driven tap changers are used. Direct-drive tap changers are equipped with capacitor-start, capacitor-run, high-torque, and reversing gear motors rated at 120 V, single-phase, 60 Hz.

- d Modern Regulator Controls. Modern regulator controls incorporate digital logic and microprocessor technology. The microprocessors used in a modern regulator control typically include an electrically erasable and programmable read-only memory (EEPROM). The EEPROM has a special memory storage where critical information, such as control settings and metering values, is stored indefinitely even during a power outage. Instead of dials and analog meter displays, the modern regulator control is equipped with liquid crystal displays (LCD) for displaying of control settings, accessory settings, metering values, and annunciator information. The regulator control is also equipped with an analog-to-digital converter that converts the analog voltage and current waveforms into digital signals. Digital signal processing techniques are applied to enhance the resolution of voltage and current signals. Modern voltage regulator controls are equipped with remote metering and control capabilities. These controls can communicate with a supervisory control and data acquisition (SCADA) system. Because of these added control capabilities, voltage regulators are used in other distribution operation functions, such as voltage reduction to support load management, voltage limiting, remote monitoring, and telemetering.

- (1) Voltage Reduction. Distribution voltage regulators are ideal devices for supporting distribution system load management. In this application, voltage regulators are manipulated to force the distribution system to temporarily operate at lower voltages. The reduction of system voltage reduces line losses and, thus, helps alleviate distribution system overloads and minimizes peak load demand. The voltage reduction function of the control is generally automatic. However, the automatic voltage reduction mode can be overridden by an operator taking local control, by a remote operator, by a SCADA system, or by the regulator's voltage limiter. When the control receives a voltage reduction signal, it triggers the voltage regulator to reduce the set voltage based on a preset percent voltage reduction. The voltage reduction control works by calculating an effective set voltage as follows:

$$\text{Eff. } V_{\text{SET}} = V_{\text{SET}} \times (1 - \%R)$$

Where:

- Eff.  $V_{\text{SET}}$  = Effective set voltage (after voltage reduction is applied)  
 $V_{\text{SET}}$  = Regulator set voltage  
 $\%R$  = Percent voltage reduction

As an example, if the set voltage is 122 V and the percent voltage reduction is 4.9%, the effective set voltage would be 116 V, i.e., a tap down of 6 V.

- (2) Voltage Limiting. The voltage limiting capability of a modern voltage regulator control is used to place an upper and lower limit on the output voltage of the regulator. The purpose of the voltage limiter is to protect consumers from abnormally high or low voltages resulting from various causes, such as rapid changes in transmission voltage, abnormal loading of the feeder, and inaccurate voltage regulator settings. The voltage limiting function is automatic; however, it can be overridden by local and remote control or by an interconnected SCADA system.
- (3) Remote Control and Telemetry. Modern voltage regulator controls have remote access capabilities that allow users to monitor, control, and set voltage regulators from a remote location. The control is equipped with analog and digital communications ports that allow interconnection with the utility's SCADA system.

Due to the strategic placement of voltage regulators within a distribution system and the availability of PTs and CTs, voltage regulators are ideal points for remote monitoring and telemetry. Advanced monitoring and telemetry functions could include tap position indication and metering of load voltage, source voltage, compensated voltage, load current, line frequency, load kVA, load kW, and load kvar.

## 5 SUBSTATION VOLTAGE REGULATORS AND SYSTEM VOLTAGE LEVELS

- a Substation Voltage Regulators. Voltage regulators are extensively used in rural electric systems to provide voltage control on distribution feeders or circuits. For substation applications, the standard practice on rural electric systems is to use substation voltage regulators in bus regulation rather than in individual feeder regulation. Bus regulation provides practical benefits in terms of lower cost, ease of operation, and less space requirements than feeder regulation. Bus voltage regulators are used to regulate the voltage level of the distribution substation secondary bus which supports multiple distribution feeders. In this application, voltage regulators are generally set to provide bus voltage at the maximum allowable voltage setting, e.g., 125 volts (on a 120-volt base) with  $\pm 1$ -volt bandwidth. In cases where the projected load center is located far from the substation, the load drop compensator (LDC) is normally used. Individual feeder regulation at the substation is only used on a few rural electric systems. Although this practice is not as popular as bus regulation, regulating the circuits individually provides greater flexibility in the overall voltage regulation of each circuit. With individual feeder regulation, the LDCs of substation voltage regulators can be employed to maximize the effect of the regulators. The principal drawback of feeder or circuit regulation is the cost of using multiple

banks of voltage regulators instead of one bank as in bus regulation. In bus regulation, single-phase or three-phase regulators can be used. Single-phase, step-voltage regulators are the most commonly used substation regulators on rural electric systems. However, in large distribution substations, typically 20 MVA and above, bus regulation in distribution substations is accomplished by using transformers with load-tap-changers. In selecting substation bus regulation equipment, there are three choices: (1) single-phase regulators, (2) three-phase regulators, and (3) load tap-changers built into the power transformer. The following are several factors that could influence the selection.

- (1) For the typical rural distribution substation size, single-phase regulators are more popular than three-phase regulators and LTCs. Using single-phase regulators allows flexibility in maintaining balanced phase voltages under conditions of unbalanced loading.
- (2) In large distribution substations, the choice of three-phase regulators may be based on costs or on the non-availability of single-phase regulators of the required size. The primary advantage of using three-phase regulators is the relatively smaller space requirement.
- (3) Power transformers with under load tap changers (LTC) are being used more in large distribution substations. Basically, they consist of a three-phase regulator built into a three-phase power transformer. The relative cost of this combination—compared to a separate transformer and voltage regulators—varies depending on the size of the substation. Aside from the base cost of the equipment, the LTC method of voltage regulation could result in savings from lesser requirements in space, buswork, and supporting structures. Failure of the LTC will likely render the transformer bank inoperative, requiring an outage to repair the LTC.

b System Voltage Profiles. When a distribution line is initially energized, the maximum drop along the line is generally less than the full 8-volt drop permitted on primary lines. This allows for future load growth to develop in a normal manner. When such a line is supplied with a constant (regulated) bus voltage at its source, its voltage profile resembles that of curve A of Figure 7. With load growth, the voltage drop along this line will increase, causing line voltages to eventually fall below the minimum limit as shown by curve B. Continued load growth beyond this point will result in excessive line voltage drop, greater than 8 volts on the primary, for some sections of the line. This is shown by curve C. Curve B demonstrates why voltage regulators alone, that regulate system voltage without consideration of system loading, are not sufficient for maintaining proper voltage levels.

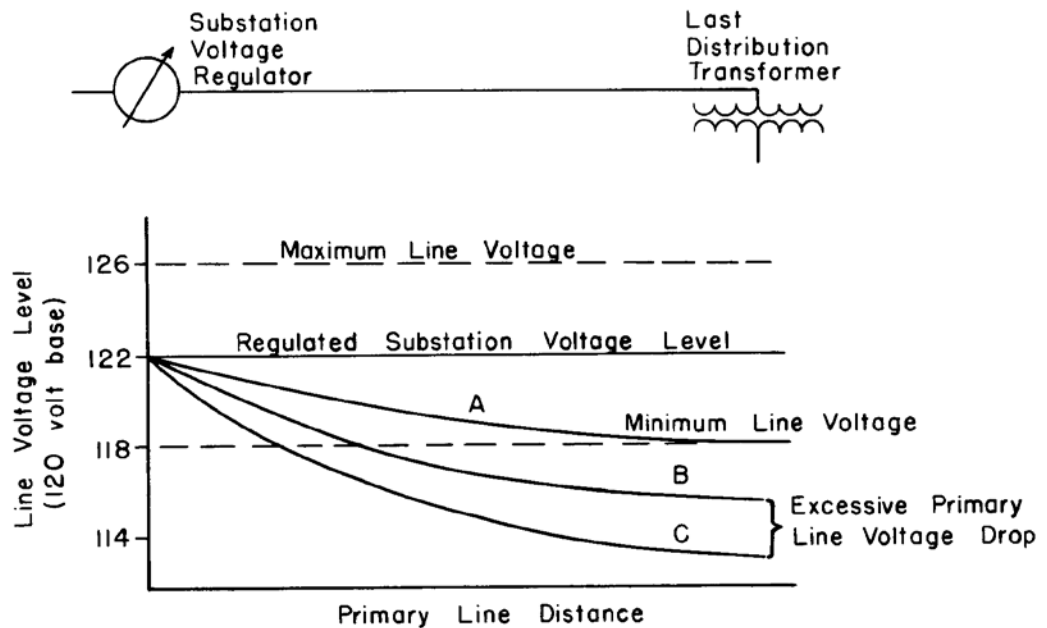

FIGURE 7: Line Voltage Profile.

- (1) Although the voltage drop represented by curve B is not greater than the full 8-volt limit permitted on primary lines, the voltage level for some segments of the line may still be below the minimum recommended line voltage. Distribution transformers served from these portions of line will have insufficient input voltage to their primary terminals and the consumers probably will have low voltage at their point of utilization. This results from the fact that, at peak load conditions, the full 8-volt voltage drop is based from a fixed substation bus voltage, regulated independently of loading.
  - (2) To be effective, system voltage regulators have to do more than provide a constant source voltage. They regulate the source voltage such that the normal distribution line voltage drops are maintained during peak load and light load conditions.
- c Effects of Line Drop Compensator. The line drop compensator (LDC) of a voltage regulator gives the latter the capability of regulating line voltage in response to changing load conditions. This capability allows the regulator to be more effective in maintaining a constant voltage output throughout all types of load conditions. An example of a voltage profile of a bus-regulated line at peak load condition without the application of LDC is shown in Figure 8.

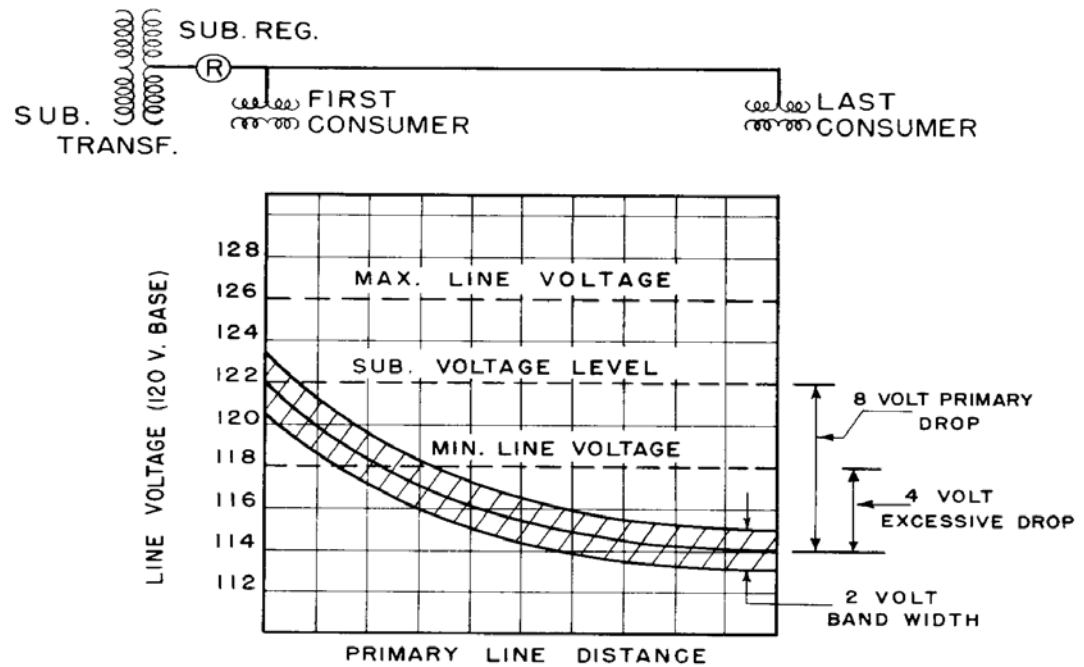

FIGURE 8: Line Voltage Drop at Peak Load  
Using Substation Regulator Without LDC

- (1) In this example, the regulated substation bus voltage is held to a constant 122 volts with a bandwidth of  $\pm 1$  volt. Notice that restricting the primary voltage drop to 8 volts maximum at peak load, while holding the substation output voltage constant, does not prevent segments of the line from receiving less than the minimum recommended line voltage (118 volts).
- (2) Figure 9 shows the same line except, in this instance, the load-sensing capabilities of the LDC are being utilized to monitor the line loading and to provide the necessary voltage adjustment to the regulator output. This adjustment is in proportion to the amount of line voltage drop caused by the loading.

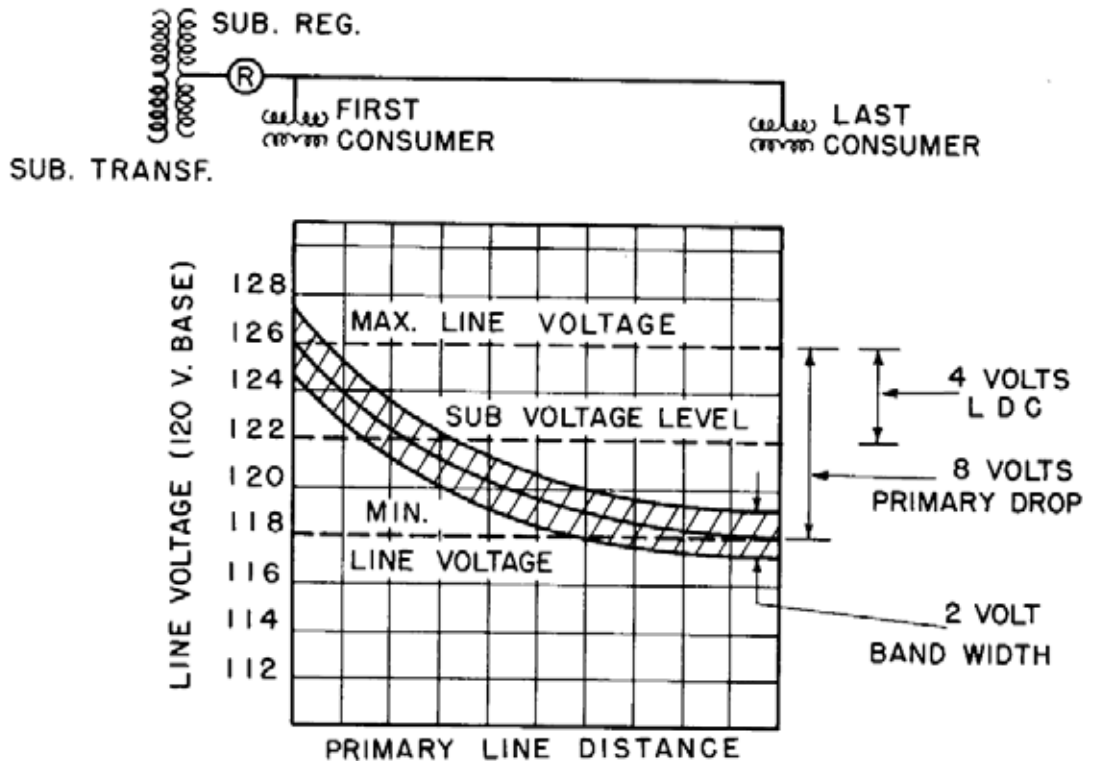

FIGURE 9: Line Voltage Drop at Peak Load  
Using Substation Regulator with LDC

- (3) During peak load conditions, the LDC adjustment is in the form of an increase in regulator output voltage at the substation bus. In effect, the regulator has increased its preset output voltage level from 122 volts to 126 volts, i.e., a 4-volt line drop compensation is added to the regulator output. This regulator output voltage compensation allows the primary line to experience a full 8-volt drop from 126 volts, without going below the minimum recommended line voltage level.
- (d) Mitigating Voltage Swings. One of the inherent advantages gained by using the LDC is the reduction of voltage swings throughout the different parts of the distribution system. This can be illustrated by the example shown in Figure 9, above. Assume that the substation voltage regulator is set to provide a constant output voltage of 126 volts *without* line drop compensation. Under peak load conditions, the 126-volt setting allows an 8-volt drop on the primary distribution line without violating the minimum allowable voltage limit of 118 volts. During light load conditions, the voltage on the primary side of the last transformer would be close to the 126-volt setting at the substation bus. Hence, from peak load

conditions to light load conditions, consumers toward the end of the circuit could experience a voltage swing of up to 8 volts at utilization points.

- (1) Without the LDC, consumers served from segments of the line closest to the substation will have nearly a constant voltage level, close to the 126-volt substation setting, while the consumers near the end of the distribution line experience maximum voltage swings at their utilization points. However, with LDC, these voltage swings can be minimized as shown by curve B in Figure 10.

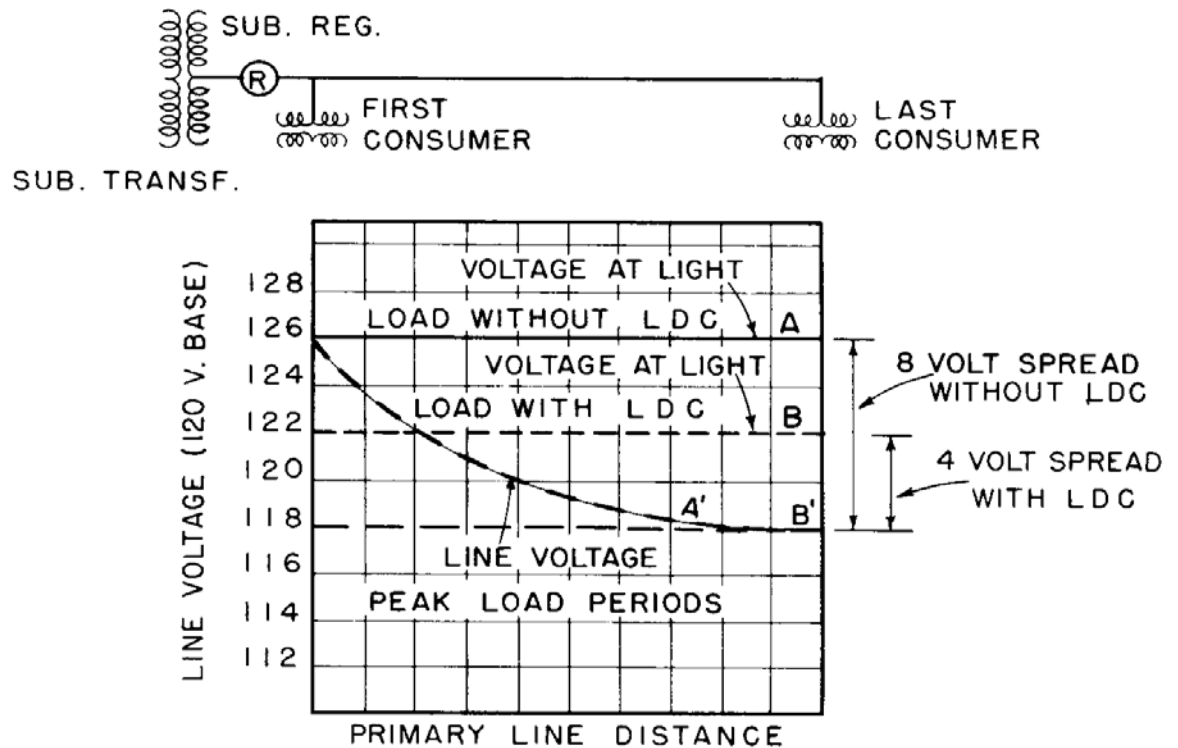

FIGURE 10: Voltage Spreads from First Consumer to Last Consumer.

- (2) In the example, the voltage is set at 122 volts. During light load conditions, it is not necessary to increase the output voltage of the regulator because the line drop compensation is at minimum. At peak loading periods, the regulator control senses a voltage below 122 volts at the system load center and introduces an additive voltage correction to the 122-volt set voltage proportional to the voltage drop on the line from the voltage regulator output to the system load center.

- (3) Without the LDC (curve A), the maximum voltage deviation from the set voltage of 122 volts would be  $\pm 4$  volts, or an 8-volt swing (or spread) from peak to light load conditions. The voltage swing is mostly experienced by consumers at the far end of the line. When LDC is properly employed, this deviation still remains  $\pm 4$  volts except the +4 volts is experienced at the substation end and the - 4 volts is experienced at the far end of the line. Thus, with the use of LDC, the maximum voltage swing of 8 volts at one end of the line is redistributed to a more balanced 4-volt voltage swing at each end of the line.

## 6 LINE VOLTAGE REGULATOR APPLICATION

### a Line Voltage Regulators

- (1) As the load grows and as the distribution line is extended, the voltage drop at the end of the line may exceed the 8-volt drop limit. The most common approach to maintaining the line voltage and getting it back to an acceptable level is by installing voltage regulators on the line. An example of a line voltage profile with excessive voltage drop is shown in [Figure 11](#) of this Bulletin. In the example, the bus is regulated at 126 volts. During peak load condition, the minimum voltage limit of 118 volts is exceeded at the primaries of distribution transformers from the middle to the end of the line. Consumers served by these transformers will experience undervoltage conditions. This voltage level violation is shown by the dashed line below the 118-volt line in [Figure 11](#).
- (2) If a voltage regulator is installed out on the line at the point where the 8-volt drop occurs, the abnormal voltage levels will be corrected, as shown in [Figure 11](#). The addition of the line voltage regulator at this point provides the same voltage control as the substation voltage regulator does upstream. The line voltage at this point is raised up to 126 volts. If LDC is used, the output of the voltage regulator will be 122 volts at light load condition and 126 volts at peak load condition.
- (3) The use of line voltage regulators allows an extension of a distribution line without violating allowable voltage limits. It defers costly replacement or uprating of conductors. In some applications, two or more line-type voltage regulators are used in a series. Line-type step-voltage regulators are only available in single-phase units. These regulators are pole-mounted on overhead primary distribution circuits and pad-mounted on underground distribution lines.



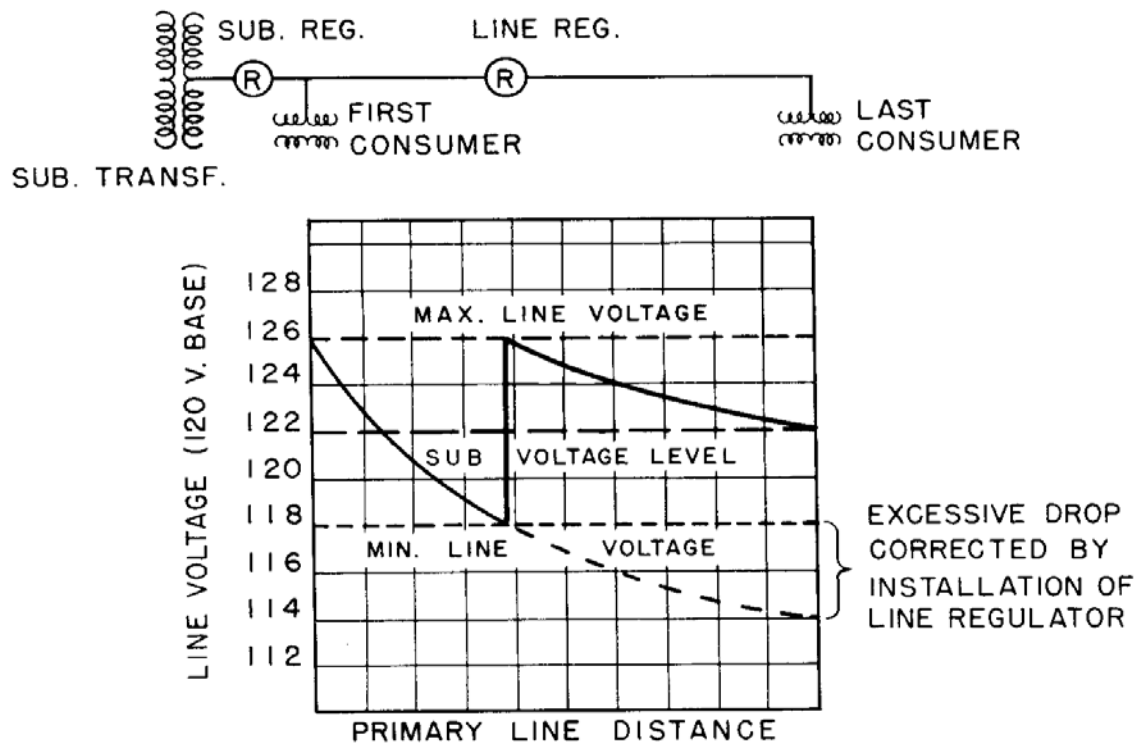

FIGURE 11: Line Voltage Profile at Peak Load Using Substation and Line Voltage Regulators.

- (4) Line-type voltage regulators are generally placed on the line where the voltage drop approaches 8 volts. More than one line-type voltage regulator may be used in a series on a distribution circuit. The decision to use more than one voltage regulator is based on economic considerations. RUS recommends that not more than two voltage regulators be installed in series on the same circuit. However, in emergency cases, and for temporary voltage correction downline, more than two cascaded voltage regulators may be used.

**b** When to Install a Line Voltage Regulator

- (1) A voltage regulator should be installed on a distribution feeder when the actual or projected primary voltage of the feeder is approaching or has dropped below the allowable limit. Line voltage regulator location has to take into consideration both present and anticipated future load conditions.
- (2) Voltage profile studies on all distribution feeders have to be performed regularly as part of the Construction Work Plan. Unscheduled voltage studies should be promptly performed on distribution feeders that display

voltage problems. Voltage profile analyses are normally conducted using commercially available computer software applications. Many of these computer programs can be run on a personal computer and are becoming more user-friendly.

- (3) Voltage recording devices installed at critical points of distribution feeders and on consumer service points can be used to effectively supplement voltage profile studies. These devices provide recorded minimum and maximum voltage levels and the time periods they occur. Modern voltage regulator controls are equipped with profile recording devices that record the regulator's voltage output into a microcomputer memory in the regulator's controller, where this information can be downloaded locally or remotely. Such control is available on both substation and line-type voltage regulators.

c Where to Install a Line Voltage Regulator

In determining the actual distance from a regulated substation to install a line voltage regulator, the following criteria need to be addressed.

- (1) Critical Loads. The location of the line regulator should benefit, if possible, voltage-sensitive or critical loads on the distribution feeder.
- (2) Long Taps. A thorough evaluation should be made to determine whether to place the line voltage regulator before or after the tap point of a long branch line or lateral. Projected load growth of the branch line must be considered.
- (3) Sectionalizing. The effects of sectionalizing and reclosing devices on voltage regulated circuits have to be taken into account. If the location is subject to a high degree of sectionalizing and recloser operations, seeking an alternative location could be an option.
- (4) Accessibility. The location has to be readily accessible for ease of maintenance and adjustment of the voltage regulator.

d Line Voltage Regulator Settings

Once the need for a regulator is established and the site is selected (in terms of physical and electrical location), the next step is to determine the following regulator control settings:

- Voltage level,
- Bandwidth,
- Time delay,
- Regulation range, and

- Line drop compensation.

These setting requirements are the same as those of substation voltage regulators. The voltage level and bandwidth are normally set the same for all voltage regulators in the distribution system, while the settings for time delay, range of regulation, and line drop compensation vary with each application.

## 7 VOLTAGE REGULATOR INSTALLATION

### a Regulator Connections for Single-Phase Circuit.

A voltage regulator can be installed to regulate a single-phase circuit or on one of the phases of a three-phase circuit. Such applications are normally found in feeder regulation. A voltage regulator can be installed by mounting it on a pole or on a crossarm platform. Voltage regulator connections for single-phase circuit regulation, such as laterals, are shown in Figure 12 of this Bulletin. Connections for regulating one phase of a three-phase circuit, such as a main distribution feeder, are shown in Figure 13 of this Bulletin.

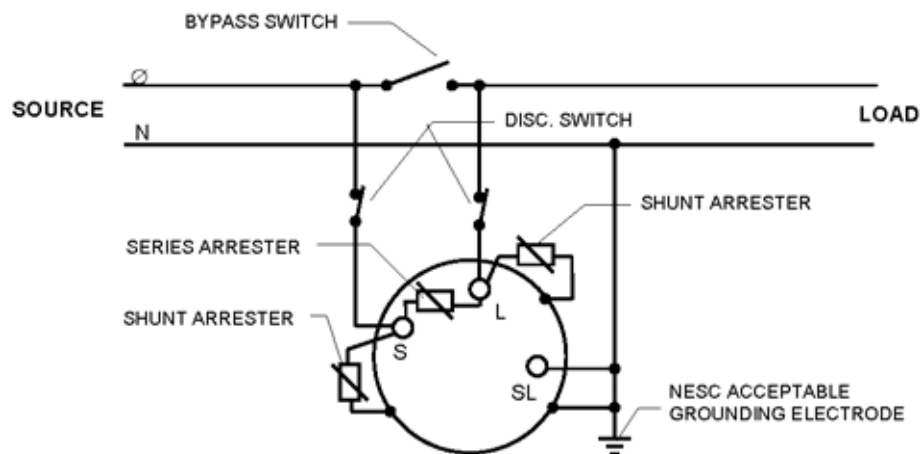

FIGURE 12: Regulator Connections for Regulating a Single-Phase Circuit.<sup>5</sup>

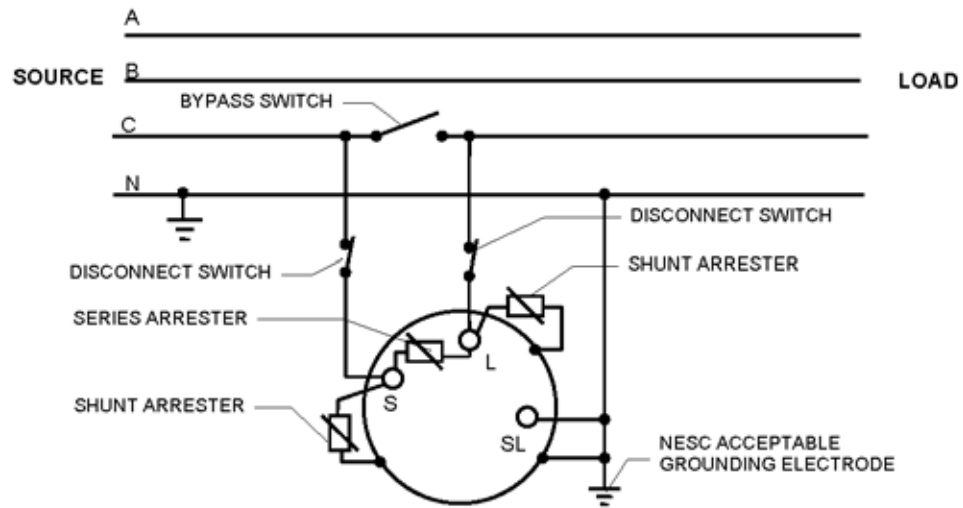

FIGURE 13: Regulator Connection for Regulating One Phase of a Three-Phase/Four-Wire Circuit.<sup>5</sup>

- b Regulator Connection for Three-Phase Circuit. Three single-phase regulators are typically used for three-phase bus and feeder regulation applications on rural distributions systems. The typical connections of three single-phase voltage regulators on four-wire/bye-connected circuits are shown in Figure 14.

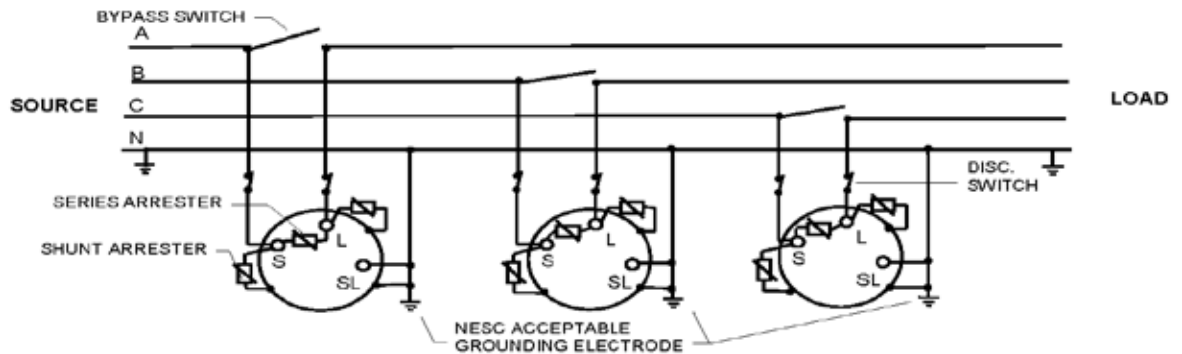

FIGURE 14: Wye Connections for Regulating a Three-Phase/Four-Wire Circuit.<sup>5</sup>

## 8 VOLTAGE REGULATOR AND CAPACITOR APPLICATIONS

- a Application Considerations. Voltage regulators are sometimes used in conjunction with power correction capacitors to significantly improve voltage profiles of distribution systems. However, careful planning for their proper coordination is needed when using both voltage regulators and capacitors. Voltage regulators are used to increase voltage levels at specific locations on a distribution system. Capacitors are used to reduce line impedances by improving

power factor and, thereby, reduce the voltage drop on the line. Voltage regulators have integral automatic controls that actively and continuously monitor and correct voltage problems on distribution circuits. Capacitors, on the other hand, are passive devices that can be installed on a fixed or switched basis. Fixed capacitors are connected to distribution systems for a long duration, while switched capacitors are installed where they can be switched on- and off-line more than once a day. Because of their differences in function and operation, capacitors can easily interfere with voltage regulators.

- (1) Capacitor banks are relatively inexpensive, easy to install, and require little maintenance. For this reason, they are popular for improving power factor, reducing current flow, and reducing voltage drops on distribution lines. Capacitor banks can be installed at the substation, at a midpoint, or at the end of a distribution line. The location of the capacitor bank is critical to its effectiveness in improving the voltage profile of the line. When on the same circuit as voltage regulators, capacitor locations have to be carefully considered in order to properly coordinate the functions of these two types of devices.
- (2) Another important issue that has to be considered when installing capacitors on the same circuit as voltage regulators is the possible creation of a deleterious harmonic resonant condition created by distributed resistor-inductor-capacitor (RLC) line components. Such resonant conditions can also cause unwanted interference by inductively coupling into nearby paralleling telecommunications circuits, thereby creating public relations problems with consumers who own the telecommunications system. If the natural resonant frequency of the RLC line components coincide with any of the frequencies of the harmonic voltages normally occurring on the power line, overvoltages and overcurrents at this frequency can occur, resulting in overheating of conductors, transformers, and motors.

b Effects of Shunt Capacitors. Shunt capacitors are used extensively in distribution systems rather than series-connected capacitors. Although series capacitors directly compensate inductive reactance on a distribution line, they present problems that complicate the operation of a distribution line. Examples of such problems include ferroresonance in transformers, subsynchronous resonance during motor starting, shunting of motors during normal operation, and difficulty in protection of capacitors, all resulting in high system fault current condition.<sup>6</sup> For these reasons, series capacitors are not popularly employed in distribution systems. Therefore, the capacitors or capacitor banks that are described and discussed in this section are shunt capacitors.

- (1) Shunt capacitors supply reactive power or current that counteracts the inductive power or current required by conductor inductances and inductive type loads. A shunt capacitor bank installed on a distribution circuit reduces

the magnitude of the source current which consequently results in the improvement of the power factor and reduction of voltage drop. The reduction of resultant source current and, consequently, the voltage drop of the line are illustrated in [Appendix B](#).

c Voltage Regulator and Shunt Capacitor Coordination

- (1) When a capacitor bank is installed on the source side of a line or circuit voltage regulator, as shown in Figure 15 of this Bulletin, coordination will not be a problem between the capacitor bank and the regulator's load drop compensator (LDC). The leading current drawn by the capacitor bank ( $I_C$ ) counteracts the lagging line current, which results in reduced source current ( $I_S$ ) flowing from the source to the capacitor bank's point of installation. The magnitude of current flowing from the capacitor bank to the load ( $I_L$ ) is the same as the magnitude of the load current when the capacitor bank was not present. Since the same current flows through the voltage regulator, no adjustment in voltage regulator settings will be necessary.

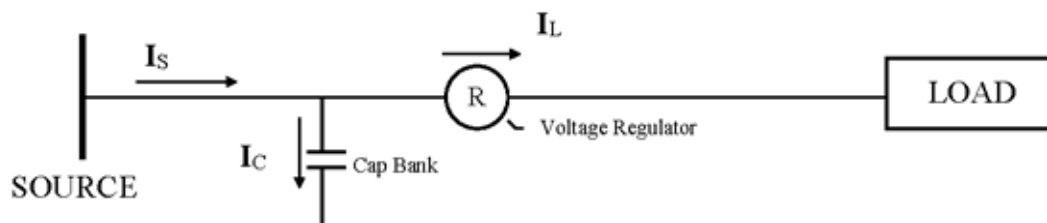

FIGURE 15: Capacitor Bank Located on the Source Side of Voltage Regulator.

- (2) When the capacitor bank is located between the voltage regulator and load, such as shown in Figure 16 of this Bulletin, the current through the voltage regulator is different from the load current. This condition presents a problem in the proper operation of the voltage regulator. During peak load condition, the regulator may see the line voltage to be sufficient because of the reduced voltage drop between the source and the capacitor bank. However, the low voltage condition across the load is not reflected at the voltage regulator since the load current is different from the regulator current. Therefore, the voltage regulator does not properly react to the low-voltage condition at the load.

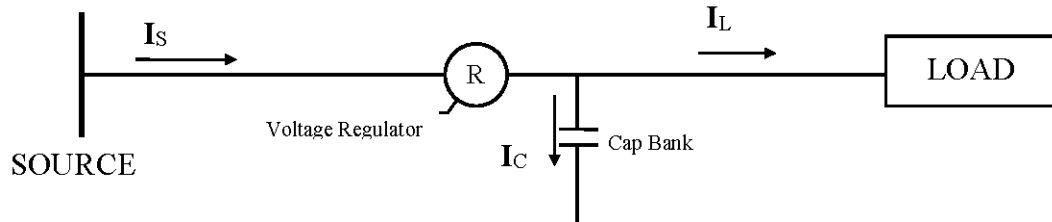

FIGURE 16: Capacitor Bank Located on the Load Side of Voltage Regulator.

- (3) To properly coordinate the voltage regulator when the capacitor bank is located between the regulator and the load, the regulator's voltage setting has to be adjusted accordingly. If no other load is served between the regulator and the load or regulating point, the new set voltage of the regulator can be calculated using the following equation.<sup>3</sup>

$$V_{\text{SET(NEW)}} = V_{\text{SET(OLD)}} + \frac{\text{CKVA}}{\text{KVA}} (X) \left(1 - \frac{L_1}{L}\right)$$

Where:

- $V_{\text{SET(NEW)}}$  = New set voltage
- $V_{\text{SET(OLD)}}$  = Old set voltage
- CKVA = Capacitor bank rating
- KVA = KVA rating based on regulator CT primary current
- X = Old regulator LDC X-setting
- $L_1$  = Distance between voltage regulator and capacitor bank
- L = Distance between voltage regulator and load or regulating point

- (4) When the capacitor bank is located on the regulating point or projected load center, coordination between the capacitor bank and voltage regulator can be accomplished by adjusting the LDC's R and X settings, taking into account the effect of leading current of the capacitor bank. The new R and X settings can be calculated by the following equations:

$$R_{\text{SET(NEW)}} = (CT_R/N_{PT}) \times R_{\text{EFF}} \text{ (volts)}$$

$$X_{\text{SET(NEW)}} = (CT_R/N_{PT}) \times X_{\text{EFF}} \text{ (volts)}$$

Where:

$$R_{\text{EFF}} = \frac{(I_{L1} + I_c)r_1d_1 + (I_{L2} + I_c)r_2d_2 + \dots}{(I_L + I_c)}$$

$$X_{\text{EFF}} = \frac{(I_{L1} + I_C)x_1d_1 + (I_{L2} + I_C)x_2d_2 + \dots}{(I_L + I_C)}$$

$R_{\text{SET(NEW)}}$	=	R voltage setting (dial or function code), in volts
$X_{\text{SET(NEW)}}$	=	X voltage setting (dial or function code), in volts
$CT_R$	=	Current transformer's primary current rating, in amperes
$N_{\text{PT}}$	=	Power transformer turns ratio, $V_{\text{PRI}} / V_{\text{SEC}}$
$R_{\text{EFF}}$	=	Effective resistance of a feeder conductor from regulator to regulation point or load center
$X_{\text{EFF}}$	=	Effective reactance of a feeder conductor from regulator to regulation point
$I_L$	=	Line current at regulator location
$I_C$	=	Current drawn by capacitor bank current
$I_{L1}$	=	Current in first section of the line before the first load is tapped off
$I_{L2}$	=	Current in second section of the line before the second load is tapped off
$r_1$	=	Conductor resistance in ohms/mile of first line section
$r_2$	=	Conductor resistance in ohms/mile of second line section
$x_1$	=	Conductor reactance in ohms/mile of first line section
$x_2$	=	Conductor reactance in ohms/mile of second line section
$d_1$	=	Length of first line section in miles
$d_2$	=	Length of second line section in miles

- d Coordination with Switched Capacitor Banks. Switched capacitor banks are more difficult to coordinate with voltage regulators. When the capacitor bank is switched on or off, the voltage regulator settings may have to be adjusted to perform properly. Since most of the settings are done locally, their adjustments and readjustments will not be practical if the capacitor bank is switched several times a day. Hence, this coordination problem has to be considered when selecting the type of capacitor to be installed.

Coordination with switched capacitor banks can be practical when the capacitor bank and voltage regulator are located close to each other. By interconnecting the two control circuits, correct voltage regulator operation can be attained throughout all load conditions. There are several possible methods for the voltage regulator control circuit to obtain the correct line drop compensation. Two of these methods are discussed below.

- (1) A current transformer can be installed in the capacitor bank circuit and interconnected with the current transformer of the voltage regulator control circuit, such as shown in Figure 17 of this Bulletin. With the current transformer interconnection, the secondary capacitor current flows



only between the two transformers and through the LDC R and X elements of the regulator control. In effect, the actual line drop compensation will result regardless of whether the capacitor bank is on-line or off-line.

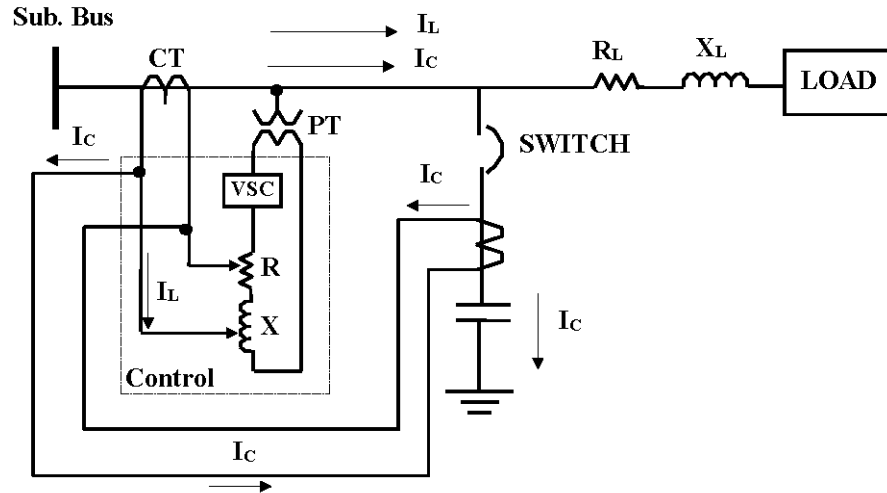

FIGURE 17: Interconnection of Current Transformers.<sup>7</sup>

- (2) Another possible method is to insert an impedance in the regulator control circuit with a magnitude such that voltage drop across it is equal to the voltage rise in the LDC elements due to capacitor current, such as shown in Figure 18. An auxiliary contact is connected across the impedance  $Z$  so that when the capacitor bank is switched off line, the impedance is shorted out. The shorting contact is interlocked with the capacitor switch.

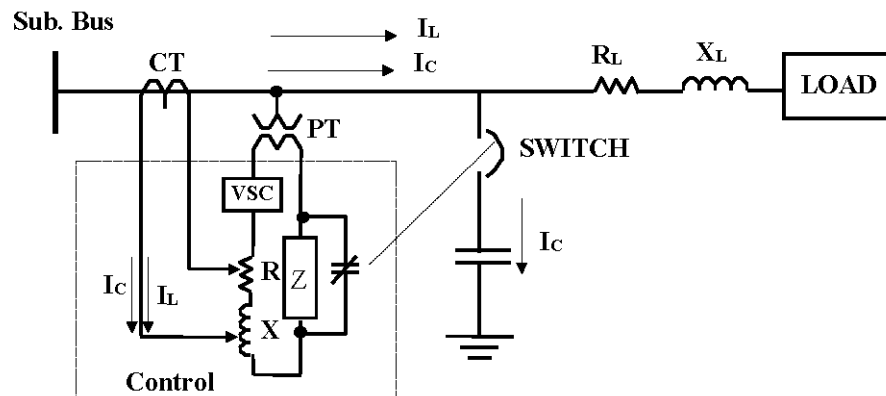

FIGURE 18: Alternative Interconnection of Current Transformers.<sup>3</sup>

## 9 VOLTAGE REGULATOR PROTECTION

- a Surge Protection. Voltage regulators, like other elements of the distribution system, require protection from lightning and other high-voltage surges. Because voltage regulators are constructed like auto-transformers—having one of the windings in series with the primary line—additional protection is required for the series winding. Regulators are normally factory-equipped with by-pass arresters across their series windings. The arresters limit the voltage developed across the series winding during surges to keep them within safe values. However, bypass arresters protect only the series winding of the regulator and do not eliminate the need for distribution class arresters to protect the regulator itself. For protection of shunt windings, an optional shunt arrester may be used and mounted between the L bushing and ground. For additional protection, another shunt arrester may also be installed between the S bushing and ground.
- b Reverse Power Flow Protection. Typically, voltage regulators are used on distribution circuits with well-defined power flow from source to load. Voltage regulators designed to operate only in one power flow direction will not operate as desired when the power flow direction is reversed. During a reverse power flow condition, the regulator will respond to a low-voltage condition by further lowering the output voltage and will respond to a high-voltage condition by further raising the output voltage. To prevent misoperation of a voltage regulator in the event of reverse power flow, the regulator control has to have a safeguard that senses the reverse power flow and automatically switches the regulator into idle or neutral mode.

Some regulator applications, however, may involve interconnected or looped circuits in which power is meant to flow through the regulator from the opposite direction. For optimum distribution system performance, a regulator installed in such circuits has to have the capability of detecting reverse power flow, and of sensing and controlling the voltage regardless of the power flow direction. In order to accomplish automatic reverse operation, the regulator control has to be able to sense the source-to-load differential voltage in addition to load voltage. A source-to-load differential potential transformer (PT) or an external source-side PT will be required. A second transformer called the Ratio Correcting Transformer will also be required to properly correct the source voltage.

- c Voltage Regulator Bypassing. It is sometimes necessary to take a regulator out of service for maintenance or replacement. It is very important that proper bypassing procedures are followed. Of primary concern is making sure that the bypass switch of a regulator is *never* closed without the regulator itself being in the “Neutral” position.
- (1) When a regulator is in any position other than “Neutral,” there is a potential difference between the source and load terminals. Closing the bypass switch of a regulator that is off “Neutral” will cause a circulating current to flow

within the regulator that will likely cause failure of the unit. This current can easily reach magnitudes of several hundred or even thousands of amps. In many cases, the conductor connecting the regulator to the phase wires will physically move back and forth or actually melt in two. This can create both a safety and a fire hazard.

- (2) Never rely solely on the position indicator to determine whether or not a regulator is in the “Neutral” position. Verify proper operation of the indicator by making use of the neutral light within the regulator control and/or an appropriate voltage-measuring device to ensure that there is no potential difference between the source and load terminals of the regulator. *Do not* use an ordinary voltmeter for this purpose.
- (3) If a regulator needs to be bypassed, and the unit cannot be placed in the “Neutral” position due to equipment problems, the safest course of action is to de-energize the primary line that serves the regulator installation. Once the line is de-energized, then the source and load switches can be opened and the bypass switch closed. The line can then be re-energized.

## 10 REFERENCES

<sup>1</sup> American National Standards Institute, “American National Standard for Electric Power Systems and Equipment—Voltage Ratings (60 Hz),” ANSI C84.1-2016.

<sup>2</sup> RUS Bulletin 1724D-113, “Voltage Levels on Rural Distribution Systems.”

<sup>3</sup> Westinghouse Electric Corp., “Distribution Systems: Electric Utility Engineering Reference Book,” Westinghouse, 1965.

<sup>4</sup> American National Standards Institute Publication, “IEEE Standards Requirements, Terminology and Test Code for Step-Voltage and Induction-Voltage Regulators,” ANSI/IEEE C57.15-2009.

<sup>5</sup> Cooper Power Systems, “Voltage Regulators,” Service Information S225-20-1, 1992.

<sup>6</sup> Gönen, Turan, “Electric Power Distribution System Engineering,” McGraw-Hill, Inc., 1986.

<sup>7</sup> Cooper Power Systems, “Voltage Regulator and Capacitor Application Considerations in Distribution Systems for Voltage Improvement,” System Engineering Reference Bulletin SE9701.

**APPENDIX A****DERIVATION OF FORMULAS FOR CALCULATING  
VOLTAGE DROP AND VOLTAGE REGULATION**

As can be observed from Figure A-1, the voltage at the source ( $V_S$ ) is equal to the vector sum of the voltage at the load ( $V_R$ ) plus the voltage impressed on the line  $IZ$ , or

$$V_S = V_R + IZ.$$

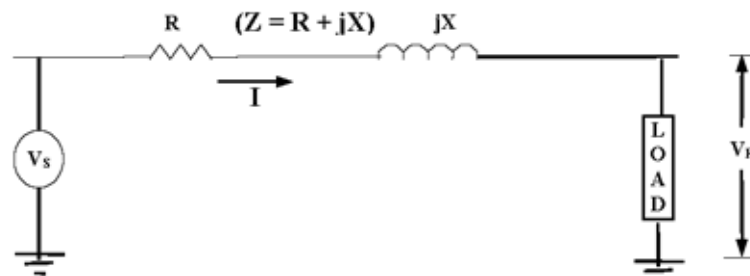

- R - Line resistance
- X - Line inductive reactance
- Z - Line impedance
- I - Line current
- $V_S$  - Source voltage
- $V_R$  - Receiving-end voltage

FIGURE A-1: A Simple Distribution Circuit Diagram.

The voltage impressed on the line ( $IZ$ ) is the actual voltage drop, which can be expressed as a vector. In practice, however, voltage drop is determined by taking the difference between the known voltage magnitudes of the sending and receiving ends as expressed by the following equation:

$$VD = |V_S| - |V_R|$$

The relationship of the voltage and current phasors of the simple circuit of Figure A-1, with a lagging power factor, is shown in Figure A-2. As shown in Figure A-2,  $VD$  is not equal to  $IZ$  drop. However, for the purposes of distribution circuit calculations, the difference between  $VD$  and  $IZ$  drop is insignificant. For known sending-end voltage and power factor,  $VD$  can be approximated by the following equation:

$$VD = IRCos \phi + IXSin \phi$$

Where:

$$I = \text{Line current}$$

- $q$  = Phase angle between voltage and current and can be derived from known power factor  
 $R$  = Resistance of the line  
 $X$  = Inductive reactance of the line

It can be observed from the phasor diagram of Figure A-2 that the approximation of VD using the above equation is sufficiently accurate.

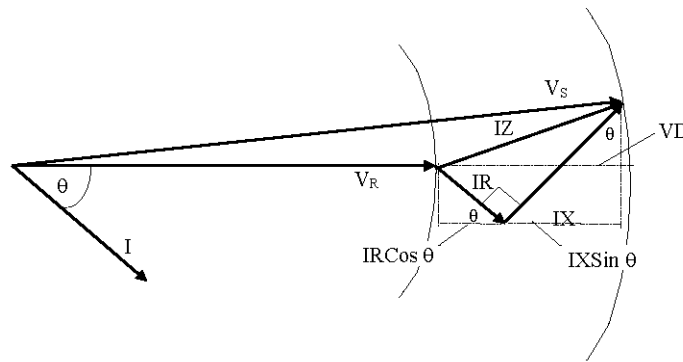

FIGURE A-2: Voltage-Current Phase Relations.

Specifically, for three-phase laterals and feeder mains, the approximate voltage drop is expressed as:<sup>6</sup>

$$VD = I_{3f} (R \cos q + X \sin q)$$

and for the single-phase lateral:

$$VD = I_{1f} (K_R R \cos q + K_X X \sin q)$$

where constants  $K_R$  and  $K_X$  are each typically assumed to be 2.0.

Voltage drop values on a distribution system are based on the nominal system voltage. To convert these values to 120-volt base, the following equation is used.

$$VD = \frac{\text{Actual Voltage Drop}}{\text{Nominal System Voltage}} \times 120 \text{ volts}$$

Voltage regulation is a measure of performance of a distribution circuit with respect to voltage drop. The voltage regulation of a distribution circuit is the ratio of the voltage drop of the line to the load voltage which can be presented in percent regulation as expressed in the following equation:

$$\% \text{ VR} = \frac{|V_S| - |V_R|}{|V_R|} \times 100$$

Where:

% VR = Percent Voltage Regulation

|V<sub>S</sub>| = Sending-end voltage of a distribution line

|V<sub>R</sub>| = Receiving-end voltage of a distribution line

## APPENDIX B

## EFFECT OF SHUNT CAPACITOR ON SOURCE CURRENT AND LINE VOLTAGE

The effect of shunt capacitors is shown in Figures B-1 and B-2. A schematic diagram of a simple distribution circuit is shown in Figure B-1 (a) and the corresponding voltage-phasor diagram is shown in Figure B-1 (b). As shown in Figure B-1 (b), load current ( $I$ ) lags the load voltage ( $V_L$ ) by phase angle  $\phi$ . Notice that the load current is the same as the source current. When a capacitor bank is installed on the circuit, as shown in Figure B-2 (a), the capacitor bank draws a leading reactive current ( $I_c$ ) that counteracts the lagging reactive load current, resulting in the reduction of the source current up to the point of capacitor bank installation. As shown in the resultant voltage and current phasor diagram of Figure B-2 (b), the magnitude of resultant source current ( $I'$ ) is reduced. However, the magnitude of load current ( $I$ ) remains the same. Also, the improvement of the power factor is clearly shown.

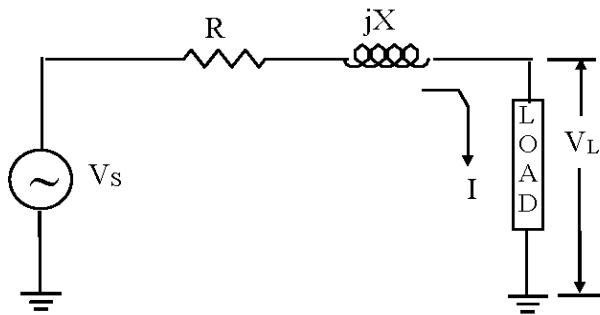

(a)

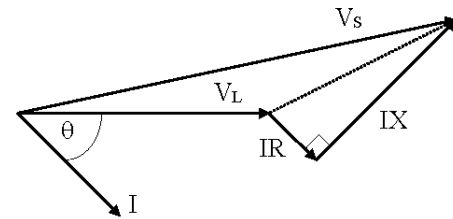

(b)

Figure B-1:

(a) Schematic Diagram of a Simple Feeder

(b) Voltage and Current Phasor Diagram

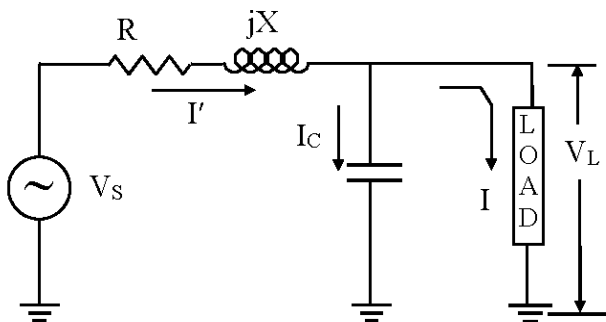

(a)

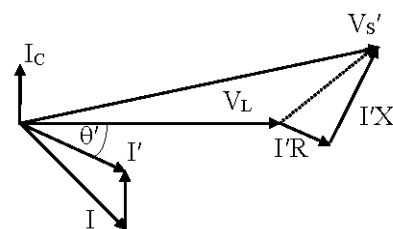

(b)

Figure B-2:

(a) Schematic Diagram of a Simple Feeder with Shunt Capacitor

(b) Voltage and Current Phasor Diagram