

# THE CONSERVATION FUND

---

BRAD A. MEIKLEJOHN  
ALASKA REPRESENTATIVE  
2727 HILAND ROAD  
EAGLE RIVER, ALASKA 99577  
(907) 694-9060  
[BRADMEIKLEJOHN@AOL.COM](mailto:BRADMEIKLEJOHN@AOL.COM)

May 5, 2010

Mr. Glen Martin  
Alaska Power and Telephone Company  
Post Office Box 3222  
Port Townsend, WA 98368

RE: Estimate of In-lieu Fee Compensatory Mitigation for POA-2009-445, Yerrick Creek, Alaska

Dear Mr. Martin,

This letter is in response to your request for an estimate of the appropriate in-lieu fee for compensatory mitigation associated with your project. It is our understanding that your project will impact approximately 0.8 acres of wetlands along Yerrick Creek, approximately 20 miles west of Tok, Alaska.

The new rule on compensatory mitigation, published in April 2008 by the Environmental Protection Agency and the U.S. Army Corps of Engineers, provides the legal framework for mitigating wetland losses for all regions of the country, including Alaska. The guiding principle of “no net loss” of the nation’s water resources is reiterated and reinforced in the new mitigation rule.

The Conservation Fund has a Memorandum of Agreement with the Alaska District of the U.S. Army Corps of Engineers to receive in-lieu fee compensatory mitigation. As provided by that agreement, The Conservation Fund uses the mitigation fees to purchase and protect high-priority wetlands. However, preserving some wetlands does not mitigate the loss of others and does not fulfill the “no net loss” mandate. As a result, the 2008 rule requires that mitigation ratios higher than 1:1 be used where preservation is used as mitigation.

We understand that compensatory mitigation will be required by the Army Corps of Engineers at a 1.5:1 ratio for this project. As a result, the compensatory mitigation for this project will be sufficient to purchase and permanently preserve 1.2 acres of similar wetlands.

In calculating an estimate of the appropriate in-lieu fee, we consider the following:

1. The costs to purchase land, including but not limited to the purchase price, appraisals, surveys, title research, legal expenses and closing costs.
2. The costs to own and manage land in perpetuity, including but not limited to physical and legal defense, property taxes, stewardship fees and management expenses.

When we evaluated the cost to purchase 1.2 acres of wetlands in the project vicinity, we looked at recent real estate transactions, current real estate listings, and property values in the project area.

We selected a base mitigation rate of \$5,000 per acre to calculate the mitigation fee. The land costs for 1.2 acres of wetlands are \$6,000. Transaction costs are estimated at \$1,500 and the long-term stewardship costs are calculated at 20% of the land costs, or \$1,200.

**Thus, the total in-lieu fee for this project is determined to be \$8,700.**

Payment can be made by sending a check to:

The Conservation Fund  
2727 Hiland Road  
Eagle River, Alaska 99577

Please contact me at (907) 694-9060 if I can be of further assistance.

Sincerely,



Brad Meiklejohn  
Alaska Representative

(BLANK PAGE)



**This notice of authorization must be  
conspicuously displayed at the site of work.**

**United States Army Corps of Engineers**  
Yerrick Creek

A permit to: CONSTRUCT A HYDROPOWER FACILITY: DIVERSION DAM &  
APPURTENANCES; BURIED PENSTOCK CREEK CROSSING; SINGLE LANE BRIDGE;  
TAILRACE TERMINUS; TEMPORARY COFFERDAMS & BRIDGES; TEMPORARY CREEK  
DIVERSIONS; EXCAVATION & BACKFILL; CREEK & BANK RESTORATION ACTIVITIES.

has been issued to: ALASKA POWER AND TELEPHONE COMPANY

on: 30 APRIL 2010 and expires on: 18 MARCH 2012

Address of Permittee: P.O. BOX 3222, PORT TOWNSEND, WA 98368, TELEPHONE  
360-385-1733, GLEN MARTIN.

**Permit Number:**

POA-2009-445

**District Commander**  
**HARRY A. BAIJ JR.**  
**PROJECT MANAGER**  
**REGULATORY DIVISION**



REPLY TO  
ATTENTION OF:

DEPARTMENT OF THE ARMY  
U.S. ARMY ENGINEER DISTRICT, ALASKA  
REGULATORY DIVISION  
P.O. BOX 6998  
ELMENDORF AFB, ALASKA 99506-0898

APR 30 2010

Regulatory Division  
POA-2009-445

Mr. Glen Martin  
Alaska Power and Telephone Company  
Post Office Box 3222  
Port Townsend, WA 98368

Dear Mr. Martin:

This is in response to your application for a Corps of Engineers permit for construction of a hydroelectric diversion dam and associated infrastructure in the waters of Yerrick Creek. The permit application has been assigned file number POA-2009-445, Yerrick Creek, which should be referred to in correspondence with us. The project area includes sites within sections 1, 2, 11 & 14, T. 18 N., R. 09 E., and section 36, T. 19 N., R. 09 E., U.S. Geological Survey Quadrangle Tanacross B-6, Copper River Meridian; approximate latitude 63.34529°N and longitude 143.62954°W. The project site is approximately 20 miles west of Tok, Alaska and near Milepost 133.5 of the Alaska Highway. Yerrick Creek flows north and empties into the Tanana River.

Your proposal includes a water diversion dam and appurtenances, buried penstock creek crossing, single lane bridge, tailrace terminus, temporary cofferdams and bridges, temporary creek diversions, excavation and backfill, creek and bank restoration activities, etc. in waters of the U.S. to produce year-round hydroelectric power to the local area.

Section 404 of the Clean Water Act requires that a Department of the Army (DA) permit be obtained for the placement or discharge of dredged and/or fill material into waters of the U.S., including jurisdictional wetlands (33 U.S.C. 1344). The Corps defines wetlands as those areas that are inundated or saturated by surface or groundwater at a frequency and duration sufficient to support, and under normal circumstances do support, a prevalence of vegetation typically adapted for life in saturated soil conditions.

Based on our review of the information you furnished and available to me, I have determined the above property contains waters of the U.S., including wetlands, under the Corps' regulatory jurisdiction. The Approved Jurisdictional Determination (AJD) form can be located at our website at [www.poa.usace.army.mil/reg/ApprovedJDs.htm](http://www.poa.usace.army.mil/reg/ApprovedJDs.htm) under the above file number. This AJD is for Yerrick Creek and all its adjacent wetlands. Corps of Engineers permit authorization is necessary because your project would involve a discharge of dredged (excavated) and/or fill material into waters of the U.S. under our regulatory jurisdiction.

This approved jurisdictional determination is valid for five (5) years from the date of this letter, unless new information supporting a revision is provided to us before the expiration date. Enclosed is a Notification of Administrative Appeal Options and Process and Request for Appeal form (see section titled "Approved Jurisdictional Determination").

Based upon the information and plans you provided, I verify the work described above for construction of a hydropower facility in waters of the U.S., which would be performed in accordance with the enclosed DA permit application and plans, sheets 0-1 dated January 2010, sheet 2B dated March 2010, sheets 3-5 dated January 2010; and sheet 6A dated March 2010, is authorized by Nationwide Permit (NWP) Number 17, Hydropower Projects. NWP 17 and its associated Regional and General Conditions can be accessed at our website at [www.poa.usace.army.mil/reg](http://www.poa.usace.army.mil/reg). Regional Conditions D, E, & F apply to your project. You must comply with all terms and conditions associated with NWP 17. I have enclosed a paper copy of the NWP 17 General and Regional Conditions for your use. In addition to the NWP conditions, you must comply with the following special conditions:

1. All fill slopes and disturbed areas subject to erosion and siltation of Yerrick Creek or project area wetlands shall be stabilized against erosion by revegetation either by seeding and/or transplanting species native to the immediate area. Erosion control with materials such as coir logs, straw wattles, silt fencing, fiber biodegradable mats, straw mulch etc. must be used as best management practices.
2. Migratory birds, their nests, eggs, nestlings, etc. will not be taken (disturbed in any manner). Vegetation must not be cleared between 5 May and 25 July of any year, unless the area to be cleared has been surveyed for birds and their nests, by a qualified biologist, and the land clearing or human disturbances can be conducted without a take.
3. Yerrick Creek bed and banks disturbed by construction of temporary diversion channels, cofferdams, bridges, or other disturbances must be restored to original conditions upon removal of the temporary fills or structures.
4. No equipment or machinery shall be refueled, lubricated, or maintained while in any active or inactive channels of Yerrick Creek. All debris will be cleaned from work areas authorized by this permit immediately following construction.
5. Earthen materials shall not be stockpiled adjacent to Yerrick Creek to prevent erosion and siltation of creek waters.
6. Trenching of Yerrick Creek for installation of the penstock crossing shall not occur within any flowing or open waters. The diversion must result in a dry work area. The creek bed must be restored with the large cobble rocks existing in the channel for armor protection prior to diverting the creek waters back to the original channel over the buried penstock. The creek bed and banks shall have the original elevation and contours re-established.

7. Reasonable precautions and controls must be used to prevent incidental and accidental discharge of petroleum products or other hazardous substances into any water or wetland areas. Clean-up materials shall be available on-site and used immediately to contain any spills of such pollutants. Fuel storage and handling must not be conducted in Yerrick Creek or wetland areas. Equipment leaking fuel, oil, hydraulic oil, etc. must not be operated in aquatic areas and be repaired prior to use in or near Yerrick Creek.

8. As compensatory mitigation for the permanent net loss of approximately 0.8 acre of Yerrick Creek area, the permittee shall pay an in-lieu fee to The Conservation Fund, or other Corps' In-lieu Fee Program sponsor, prior to initiating construction in waters of the U.S., at the ratio of 1 acre of creek to 1.5 acre preserved. The Conservation Fund will provide the cost per debit to the permittee at the time of payment. Proof of the in-lieu fee payment shall be provided to the Corps prior to beginning construction in the waters of Yerrick Creek.

Further, please note General Condition 26 requires that you submit a signed certification to us once any work and required mitigation are completed. Enclosed is the form to complete and return to me. I have also enclosed a Notice of Authorization to post at the work site.

This verification will be valid for two years from the date of this letter, unless the NWP authorization is modified, suspended, or revoked. The NWPs, as a program, are scheduled to be re-issued/modified in 2012. To continue your Yerrick Creek hydroelectric construction for 2012, you will need to re-apply for the nationwide permit. Note any changes to your hydropower construction plans at that time.

Nothing in this letter excuses you from compliance with other Federal, State, or local statutes, ordinances, or regulations.

Please contact me by e-mail at [harry.a.baij@usace.army.mil](mailto:harry.a.baij@usace.army.mil), by mail at the address above, by phone at 907-753-2784, or toll free from within Alaska at 800-478-2712, if you have questions. For additional information about our Regulatory Program, visit our web site at [www.poa.usace.army.mil/reg](http://www.poa.usace.army.mil/reg).

Sincerely,



Harry A. Baij Jr.  
Project Manager

Enclosures

Enclosure



US Army Corps of Engineers  
Alaska District

Permit Number: POA-2009-445

Name of Permittee: Alaska Power and Telephone Company

Date of Issuance: April 30, 2010

Upon completion of the activity authorized by this permit and any mitigation required by the permit, sign this certification and return it to Mr. Harry A. Baij Jr. at the following address:

U.S. Army Corps of Engineers  
Alaska District  
Regulatory Division CEPOA-RD-N  
Post Office Box 6898  
Elmendorf AFB, Alaska 99506-0898

Please note that your permitted activity is subject to a compliance inspection by an U.S. Army Corps of Engineers representative. If you fail to comply with this permit you are subject to permit suspension, modification, or revocation.

I hereby certify that the work authorized by the above-referenced permit has been completed in accordance with the terms and conditions of the said permit, and required mitigation was completed in accordance with the permit conditions.

\_\_\_\_\_  
Glen Martin  
Alaska Power and Telephone Company

\_\_\_\_\_  
Date





17. DIRECTIONS TO THE SITE

The Yerrick Creek Hydroelectric Project, located on Yerrick Creek, is approximately 20 miles west of Tok, at about Mile Post 1333.5 on the Alaska Highway.

18. Nature of Activity *(Description of project, include all features)*

To construct and operate a run-of-river hydroelectric project at Yerrick Creek. This project will have a concrete-and-rockfill diversion structure (about 300 feet long and up to 10 feet high) across Yerrick Creek to divert water into a 15,000 feet long pipeline ("penstock") that will transport the water to a powerhouse located about 1,500 feet upstream from the Alaska Highway, where a hydraulic turbine and generator will generate up to 1,500 kW of electricity. An excavated channel ("tailrace") about 700 feet long will discharge the water back to the creek. A 3.0 mile long access road will be constructed from the Alaska Highway to the diversion structure, which will be adjacent to the penstock for most of its length. A power cable will be buried adjacent to the access road between the powerhouse and the Alaska Highway. Please see the attached figures.

19. Project Purpose *(Describe the reason or purpose of the project, see instructions)*

The project's purpose is produce electricity from a renewable resource, thereby reducing the use of fossil fuels to provide power and heating in the communities of Tok, Tetlin, Dot Lake, and Tanacross. These communities currently rely 100% on diesel fuel for generating electricity. This project would stabilize and reduce electric rates for these communities.

AP&T expects to begin work in the spring of 2010 and complete work by the end of 2012.

USE BLOCKS 20-22 IF DREDGED AND/OR FILL MATERIAL IS TO BE DISCHARGED

20. Reason(s) for Discharge

In its planning and design for this project, AP&T considered several alternative routes for the required long penstock. Since Yerrick Creek is a very active stream, AP&T wants to minimize the exposure of the penstock to potential flood damage. However, alternatives that kept the penstock completely out of the flood plain were found to require an excessive amount of excavation in very difficult terrain. The proposed design is considered to be optimal, in that the structures in the flood plain are limited to the diversion structure, one buried penstock crossing, one bridge, and a small section of the tailrace channel. The route avoids all mapped wetlands except those associated with these few structures in the flood plain. Approximately half of the penstock/access road route is located on terraces outside of the Yerrick Creek valley, and the other half is at the base of the valley walls in forested upland well away from the active creek channel.

Initially, AP&T will construct a pioneer road from the Alaska Highway to the diversion area, including a temporary bridge over Yerrick Creek at the location of the buried penstock river crossing. This temporary bridge will consist of modified railroad cars supported on gabion abutments, with rockfill approaches. A similar temporary bridge will be installed at the diversion structure to provide access to a staging area on the west side of the creek. These temporary bridges will be removed prior to operation of the project. The railroad car bridge structures will be located above the ordinary high water elevation, so they are not included in the dredge-and-fill volumes in Section 21.

A borrow pit in the powerhouse area will be used for any roadfill needed for the pioneer road. A source of excellent road material is located in a landslide deposit along the access road alignment about 2 miles from the Alaska Highway. This deposit will be used for raising the grade of the access road and for other required structural backfill. Neither material source is located in the flood plain or mapped wetlands, and so the excavations are not included in the dredge-and-fill volumes in Section 21.

Staging areas will be created in relatively flat upland terrain near the powerhouse and diversion structure. These areas (which include the borrow pit described above) will be cleared of vegetation and used for screening and stockpiling of borrow material, as well as storage of construction materials and equipment. Appropriate erosion control measures, such as silt fencing, straw bale check dams, and sediment detention ponds, will be used to prevent release of silt-laden drainage to Yerrick Creek.

The diversion structure will include an embankment on the left (west) abutment, a spillway in the active stream channel, an intake on the right (east) abutment, and an embankment between the intake and the east valley wall. The embankments and

the spillway will be rockfill structures with upstream concrete facing. The concrete facing will be continuous with a cutoff wall to limit seepage. A grout curtain may also be required, depending on the amount of seepage observed following construction. The spillway will have two sections, a 30' section to provide fish passage (as required by the Alaska Department of Fish and Game) and a 100' section to pass flood flows. The downstream face of both sections of the spillway will be constructed of large grouted rockfill; the slope of the fish passage section will be 10:1, whereas the slope of the flood flow section will be at 4:1. The crest of the fish passage section will be 1' lower than the flood flow section. The intake will be a concrete structure with a trashrack, gates, and fishscreen as required by the Alaska Department of Fish and Game. The intake will be designed to facilitate the potential construction of a desanding facility if that becomes necessary. The spillway will be constructed after the intake, with the stream temporarily diverted through the intake by a supersack cofferdam and excavated channel. The dredge-and-fill volumes in Section 21 below are for the spillway and cofferdam, which are the only parts of the diversion structure in the mapped floodplain. The potential desander will also be located entirely in uplands. The potential grout curtain is not included in the dredge-and-fill volumes, as it will be entirely subsurface.

The upper half of the penstock will be 48 inch diameter HDPE pipe, and the lower half will be 42 inch ductile iron pipe. The buried penstock river crossing will be in the HDPE portion, with the pipe encased in reinforced concrete. The top of the pipe will be a minimum of 6 feet below the current stream level, and the excavation will be backfilled with large rock to resist erosion during flooding. The length in the floodplain is estimated to be 200 feet.

The single lane bridge over Yerrick Creek will have three 70-foot-long spans, with each span consisting of two parallel modified railroad cars. The abutments on each end will consist of welded wire walls and rockfill; one will be located outside of the flood plain, and one will be on the edge of the flood plain. The two center supports will be reinforced concrete piers setting on reinforced concrete footings. The footings will be 20 foot shipping containers filled with concrete and buried so the bottoms are at least 12 feet below the existing stream level to resist erosion during flooding. Installation of the footings will require a temporary diversion of the stream by a supersack cofferdam and diversion channel. The dredge and fill calculations in Section 21 below are for the center support footings and piers, cofferdam, one abutment, and the temporary diversion, which are the only parts of the bridge in the mapped floodplain and below the ordinary high water level.

The powerhouse will discharge into a pond created in the borrow pit for the access road. An excavated channel will return the flow from the pond to the Yerrick Creek floodplain; nearly all of this excavated channel will be in uplands. This section of the floodplain is dry except during very high floods, however, it is mapped as wetlands. In order to provide a reliable tailrace, it is estimated that about 200 feet of the floodplain will need to be reworked (excavation of high sections and placement of that same material in the floodplain downstream).

21. Type(s) of Material Being Discharged and the Amount of Each Type in Cubic Yards

Diversion Structure (Permanent Structure)

Excavation for temporary diversion channel.....	320 cubic yards
Cofferdam for temporary diversion.....	125 cubic yards
Excavation.....	1,000 cubic yards
Reinforced concrete.....	200 cubic yards
Rockfill.....	670 cubic yards
Grouted rockfill.....	770 cubic yards

Buried Penstock River Crossing (Permanent Structure)

Excavation for temporary diversion channel.....	1,750 cubic yards
Cofferdam for temporary diversion.....	90 cubic yards
Excavation for penstock.....	1,950 cubic yards
48" diameter HDPE pipe (buried under creek).....	93 cubic yards (200' length)
Reinforced concrete encasement of buried HDPE pipe.....	260 cubic yards
Rockfill (backfill of excavation).....	1,600 cubic yards

Single Lane Bridge (Permanent Structure)

Excavation.....	780 cubic yards
Reinforced concrete bridge center supports.....	140 cubic yards
Rockfill (backfill of excavations).....	520 cubic yards
Welded wire wall.....	700 square feet (exposed face)

Tailrace (Permanent Structure)

Excavation.....	490 cubic yards
Fill.....	370 cubic yards

Temporary Bridges (Temporary Structures)

Gabion abutments.....	112 cubic yards
Rockfill (approach embankments).....	600 cubic yards

22. Surface Area in Acres of Wetlands or Other Waters Filled (*see instructions*)

<u>Diversion Structure</u> .....	0.60 acres
<u>Buried Penstock River Crossing</u> .....	0.20 acres
<u>Single Lane Bridge</u> .....	0.15 acres
<u>Tailrace</u> .....	0.05 acres

Excavations will be made with tracked excavators of various sizes and capacities. Backfill will be by excavators, with compaction by plate compactors, tamping with excavator buckets, or hoe-mounted vibrators. Hauling of earthwork materials will be by standard dump trucks. Concrete will be delivered by standard concrete trucks from commercial sources or from an on-site batch plant.

23. Is Any Portion of the Work Already Complete? Yes \_\_\_\_\_ No  IF YES, DESCRIBE THE COMPLETED WORK

24. Addresses of Adjoining Property Owners, Lessees, Etc., Whose Property Adjoins the Waterbody (if more than can be entered here, please attach a supplemental list).

Property owners for this site are:

Alaska Department of Natural Resources  
 3700 Airport Way  
 Fairbanks, AK 99709-4699  
 Attn: Chris Milles, Natural Resource Mgr III

and

Tanacross, Inc.

P.O. Box 76029  
Tanacross, AK 99776

25. List of Other Certifications or Approvals/Denials Received from other Federal, State, or Local Agencies for Work Described in This Application

AGENCY	TYPE APPROVAL*	IDENTIFICATION NUMBER	DATE APPLIED	DATE APPROVED	DATE DENIED
ADF&G	Habitat Permit	FH09-III-0182	September 2008	August 5, 2009	
DNR	Land Lease		October 2007		
DNR	Water Rights		May 2007	Won't be approved until after operations start.	

\*Would include but is not restricted to zoning, building and flood plain permits

26. Application is hereby made for a permit or permits to authorize the work described in this application. I certify that the information in this application is complete and accurate. I further certify that I possess the authority to undertake the work described herein or am acting as the duly authorized agent of the applicant.

/S/ Glen D. Martin

January 18, 2010

SIGNATURE OF APPLICANT

DATE

SIGNATURE OF AGENT

DATE

The application must be signed by the person who desires to undertake the proposed activity (applicant) or it may be signed by a duly authorized agent if the statement in block 11 has been filled out and signed.

18 U.S.C. Section 1001 provides that: Whoever, in any manner within the jurisdiction of any department or agency of the United States knowingly and willfully falsifies, conceals, or covers up any trick, scheme, or disguises a material fact or makes any false, fictitious or fraudulent statements or representations or makes or uses any false writing or document knowing same to contain any false, fictitious or fraudulent statements or entry, shall be fined not more than \$10,000 or imprisoned not more than five years or both.

**PROJECT LOCATION**  
 T18N, R9E, Section 1, 2, 11, 14  
 T19N, R9E, Section 36, CRM  
 USGS Tanacross (B-6)  
 Mile Post 1333.5 Alaska Hwy  
 Approximately 20 Miles West of Tok

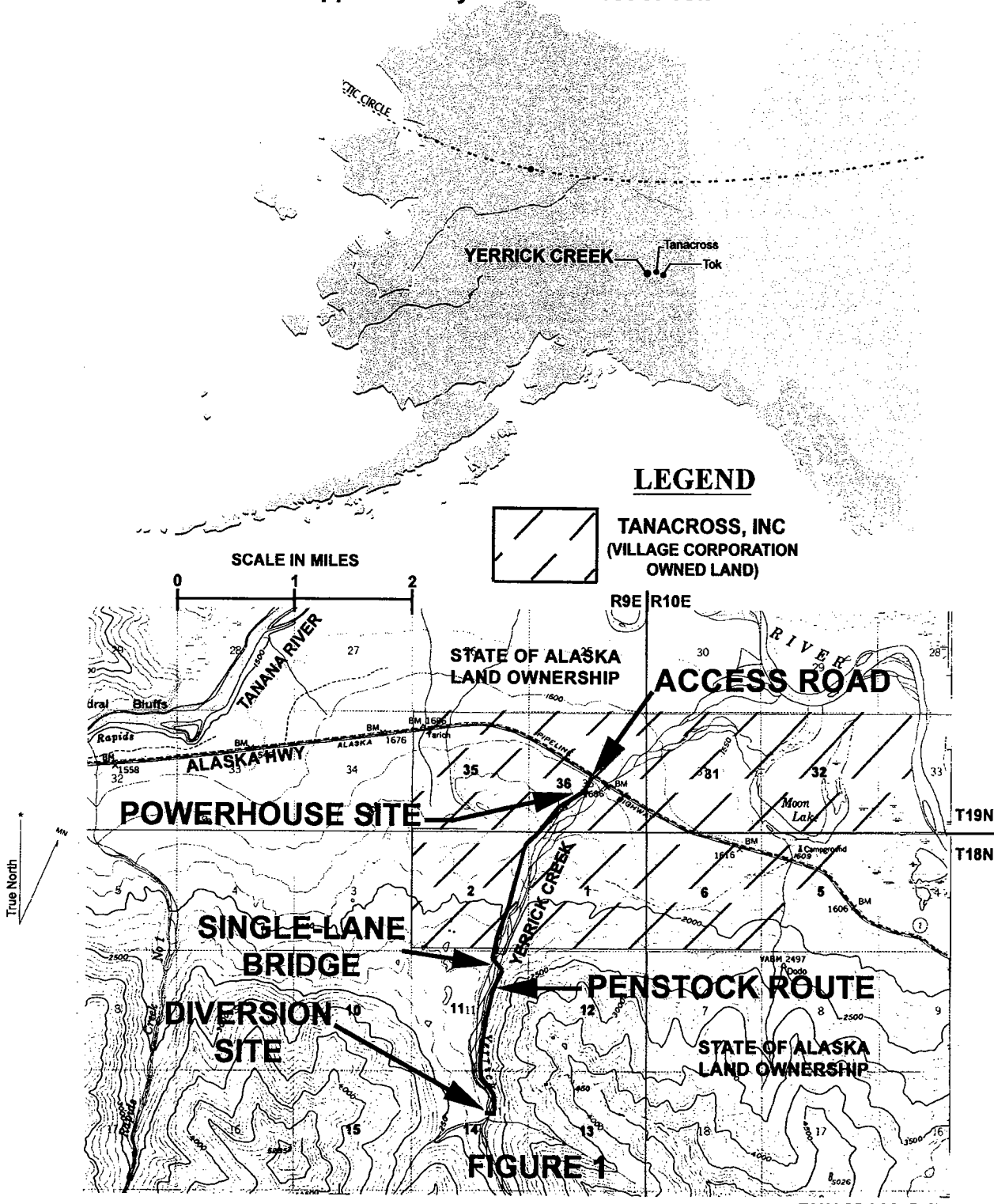

**FIGURE 1**

TANACROSS (B-6)



**YERRICK CREEK  
 HYDROELECTRIC PROJECT  
 PROJECT LOCATION  
 AND FEATURES**

DATE: JANUARY, 2010	
PROJECT NUMBER:	
SHEET NUMBER: 0	ISSUE NO.



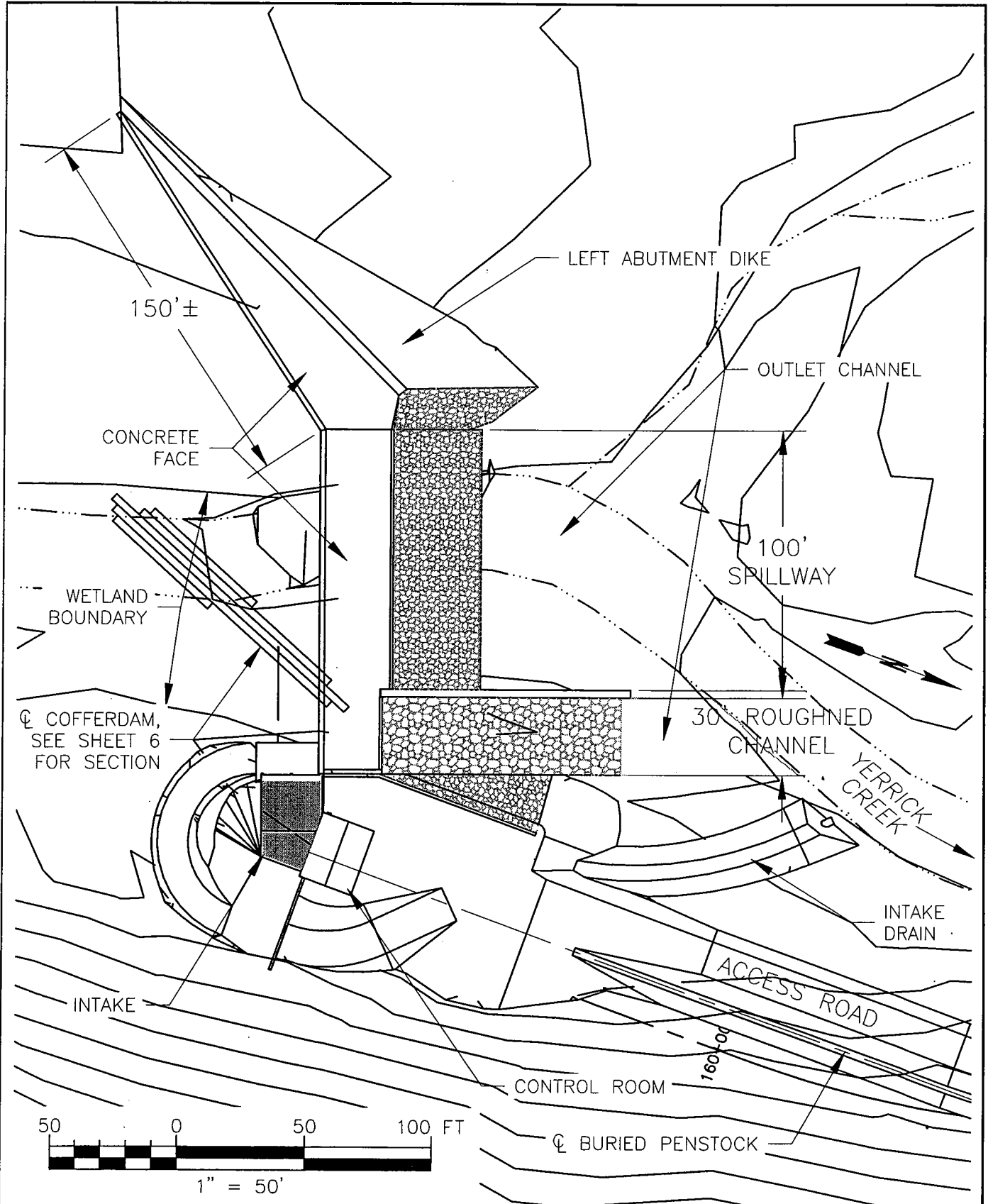

**AP&T**  
 ALASKA POWER &  
 TELEPHONE COMPANY

**YERRICK CREEK  
 HYDROELECTRIC PROJECT**  
**INTAKE STRUCTURE  
 PLAN**

DATE: MARCH, 2010	
PROJECT NUMBER:	
SHEET NUMBER: <b>2</b>	ISSUE NO. <b>B</b>



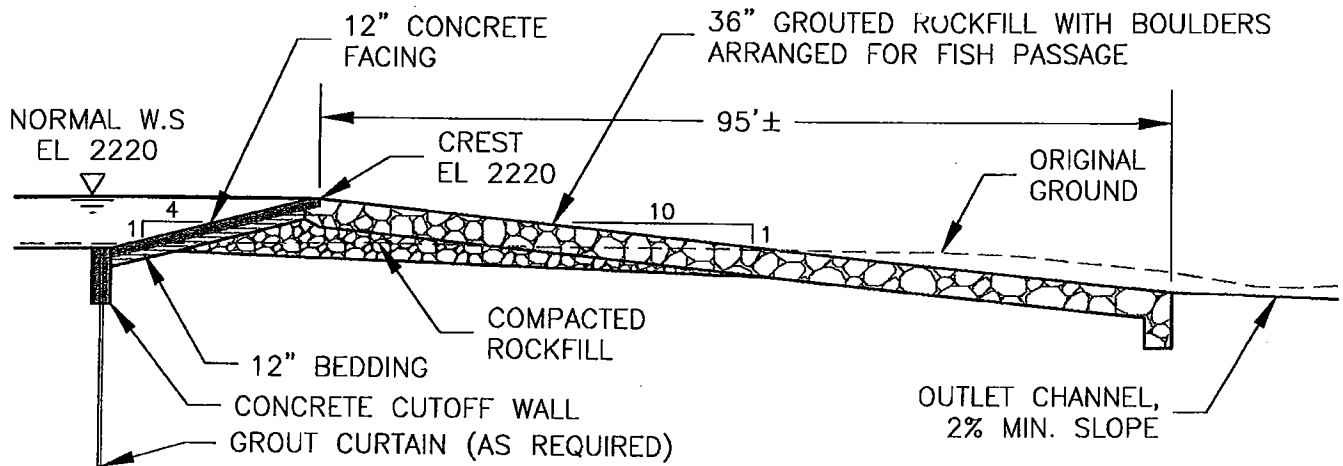

**ROUGHENED CHANNEL SECTION**  
SCALE 1"=20'

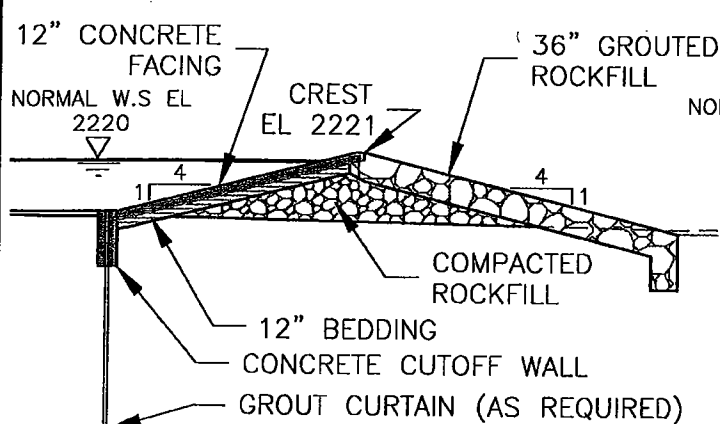

**SPILLWAY SECTION**  
SCALE 1"=20'

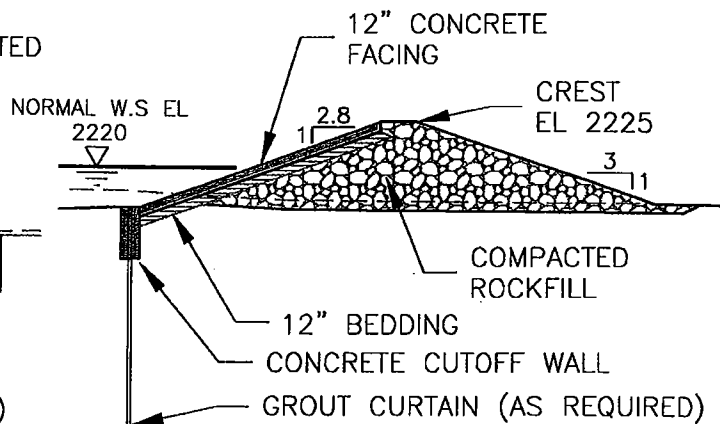

**LEFT ABUTMENT DIKE SECTION**  
SCALE 1"=20'

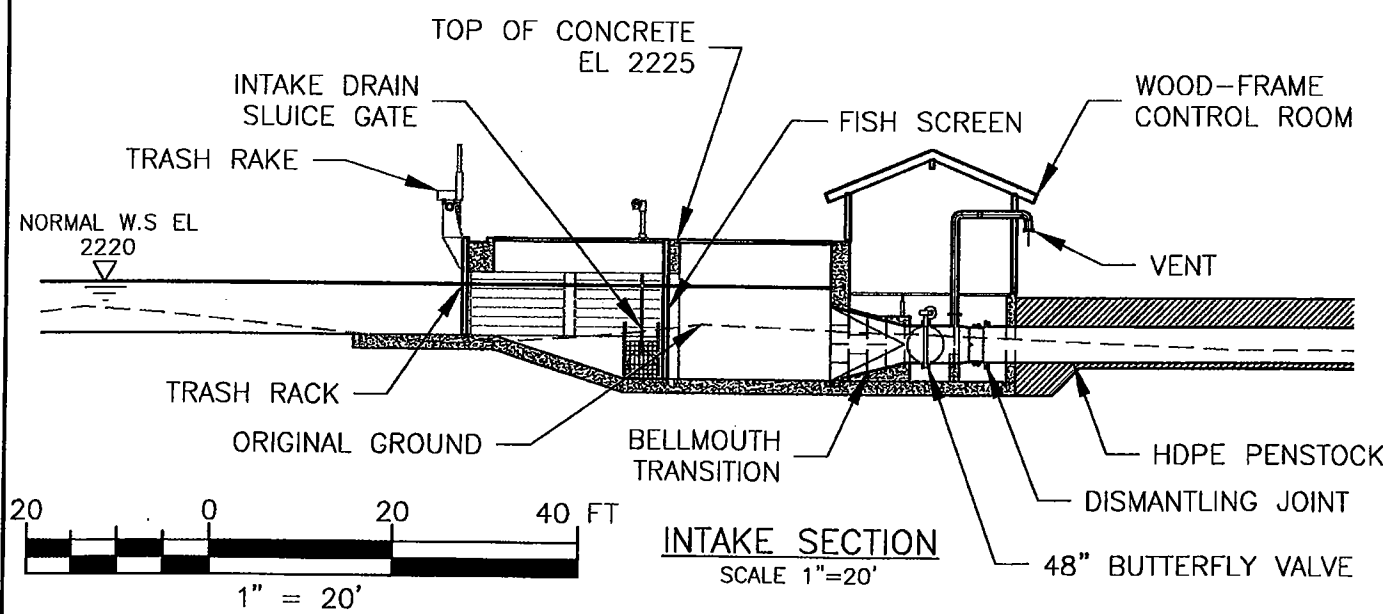

**INTAKE SECTION**  
SCALE 1"=20'



**YERRICK CREEK  
HYDROELECTRIC PROJECT**

**INTAKE STRUCTURE  
SECTIONS**

DATE: JANUARY, 2010	
PROJECT NUMBER:	
SHEET NUMBER:	ISSUE NO.
<b>3</b>	

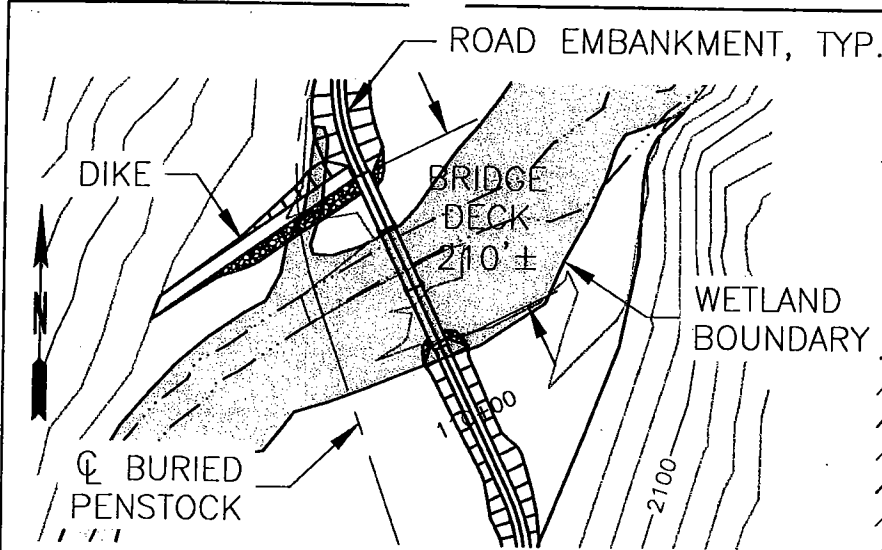

**BRIDGE AND PENSTOCK PLAN**

SCALE 1"=200'

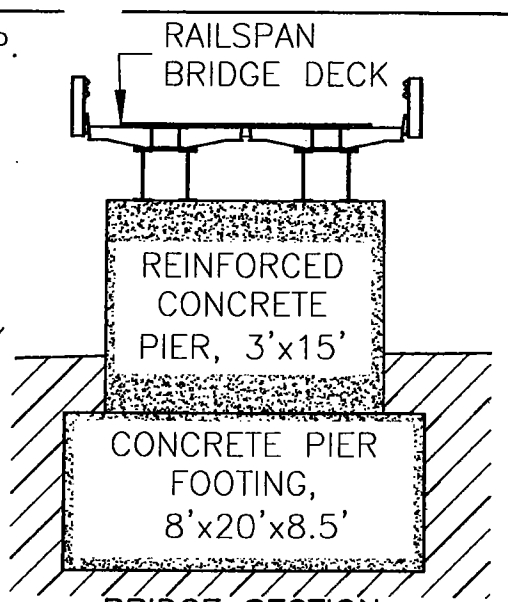

**BRIDGE SECTION**

SCALE 1"=10'

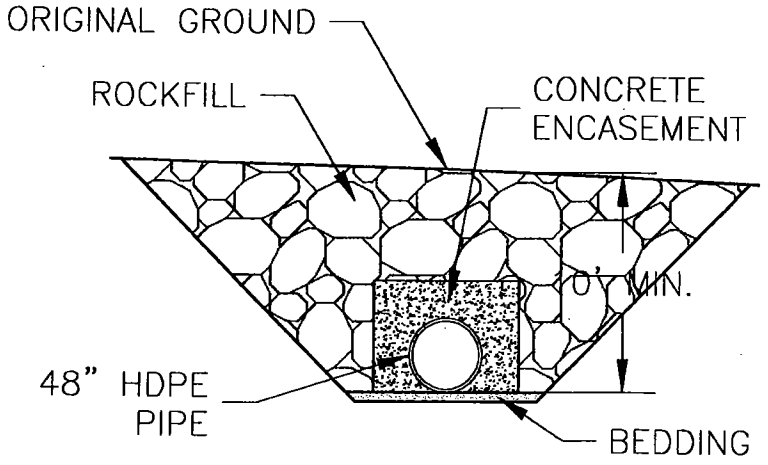
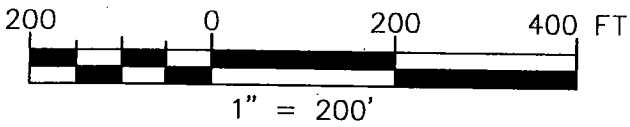
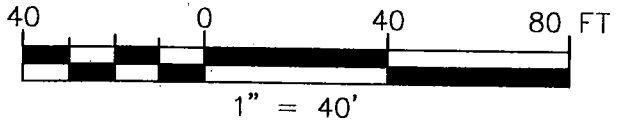
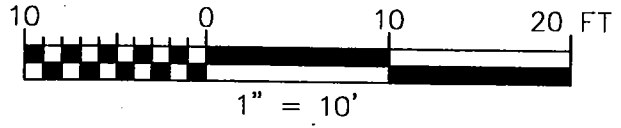

**BURIED PENSTOCK SECTION**

SCALE 1"=10'

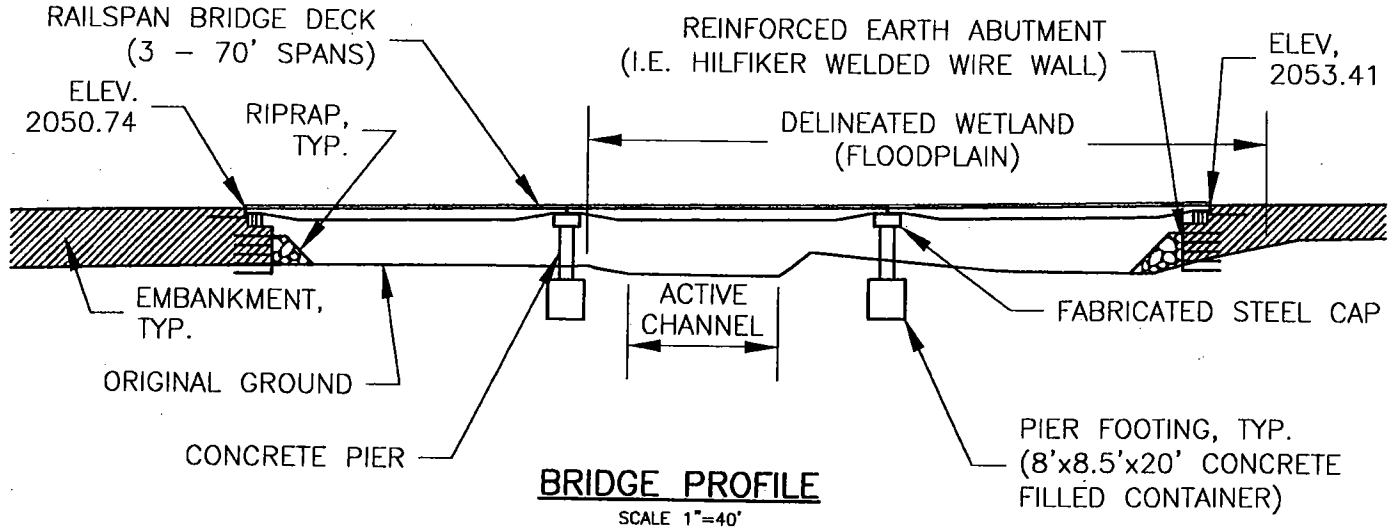

**BRIDGE PROFILE**

SCALE 1"=40'



**YERRICK CREEK  
HYDROELECTRIC PROJECT**

**BRIDGE AND PENSTOCK  
PLAN AND SECTIONS**

DATE: JANUARY, 2010	
PROJECT NUMBER:	
SHEET NUMBER:	ISSUE NO.
<b>4</b>	

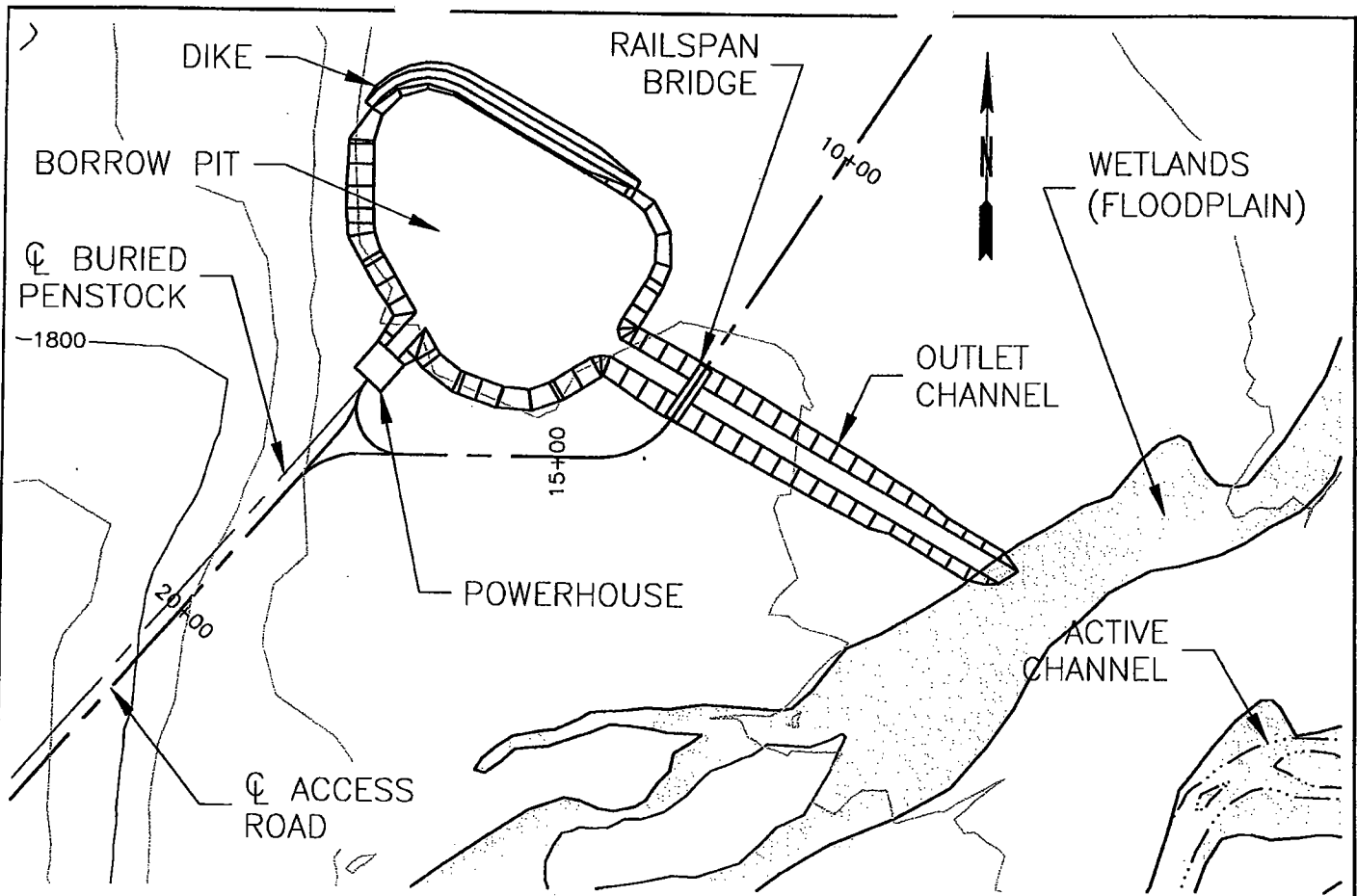

**POWERHOUSE AND TAILRACE PLAN**  
SCALE 1"=200'

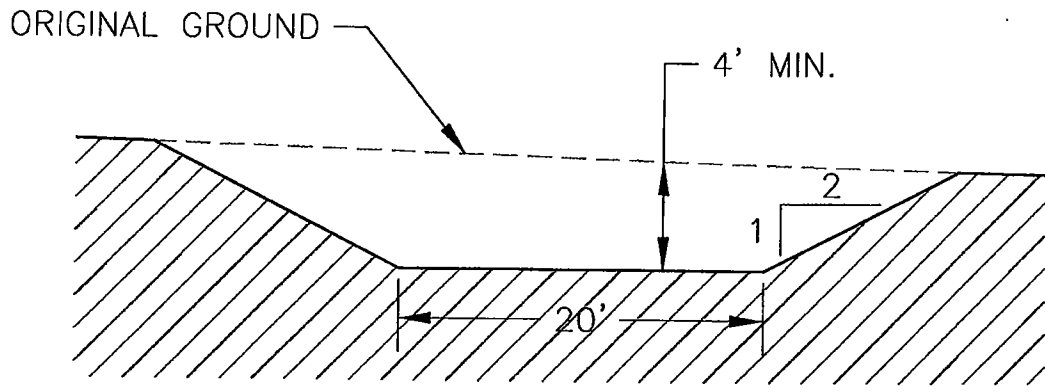

**OUTLET CHANNEL SECTION**  
SCALE 1"=10'

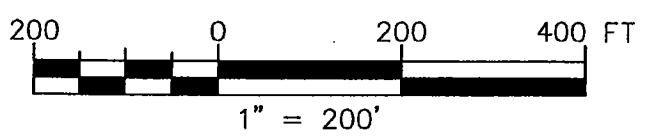
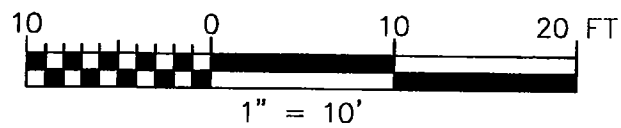

**YERRICK CREEK  
HYDROELECTRIC PROJECT**  
**POWERHOUSE AND TAILRACE  
PLAN AND SECTIONS**

DATE: JANUARY, 2010	
PROJECT NUMBER:	
SHEET NUMBER:	ISSUE NO.
<b>5</b>	

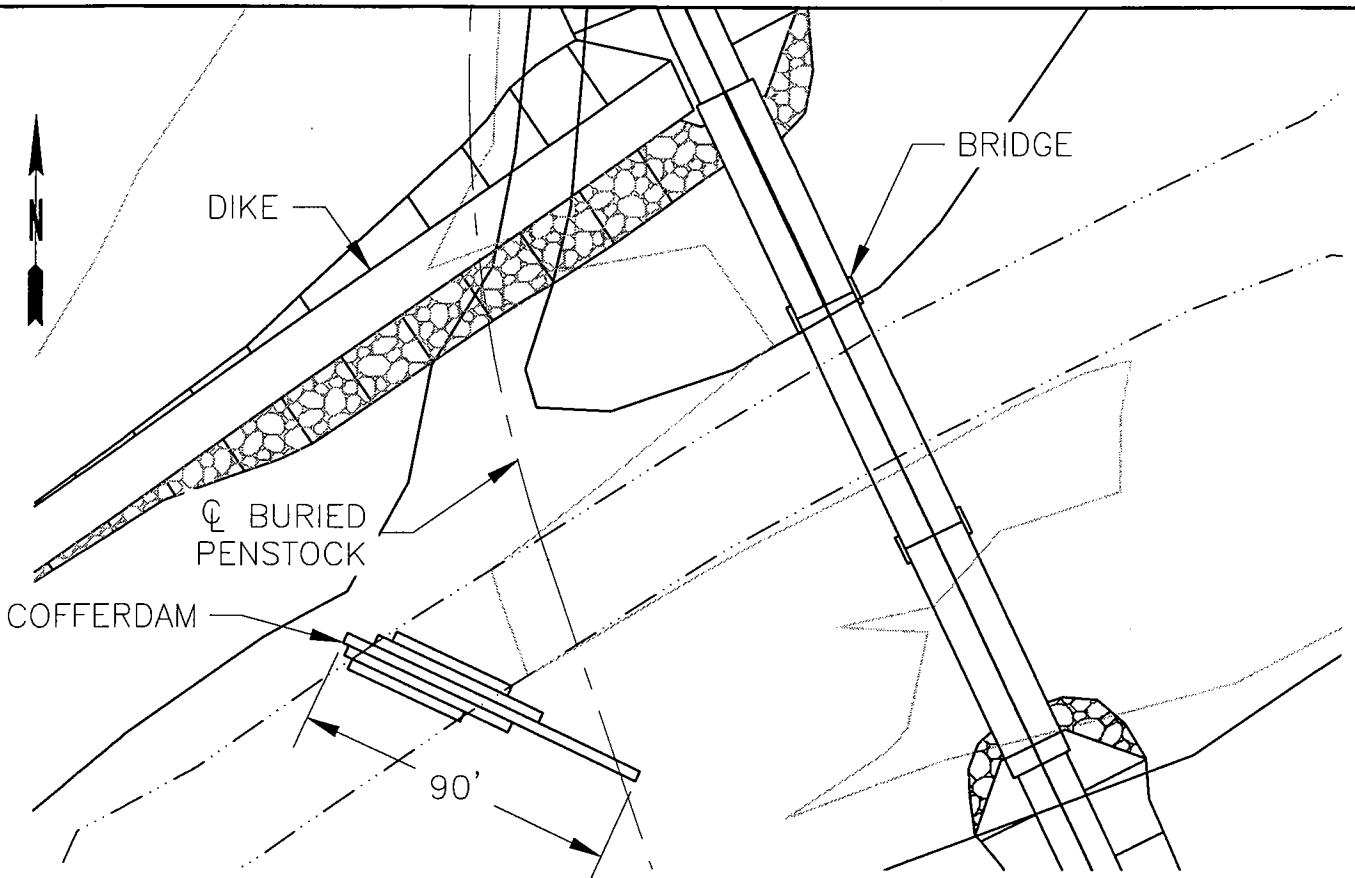

**COFFERDAM PLAN AT BURIED PENSTOCK CROSSING**

SCALE 1"=50'

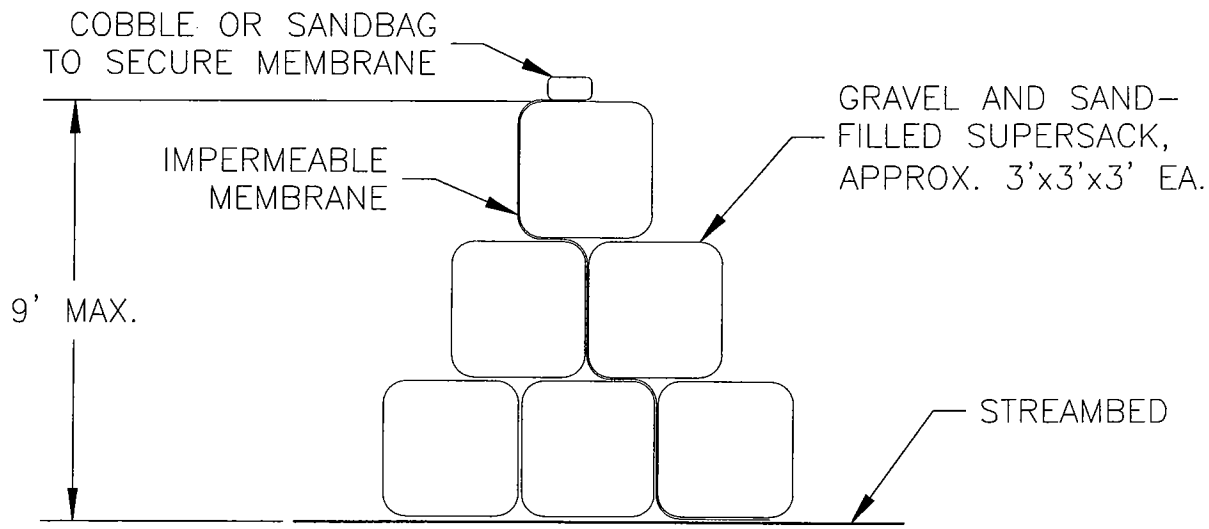

**COFFERDAM SECTION**

SCALE 1/4"=1'-0"

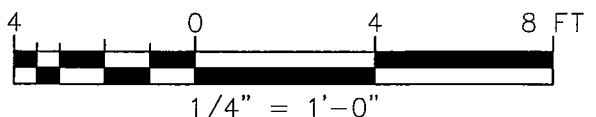
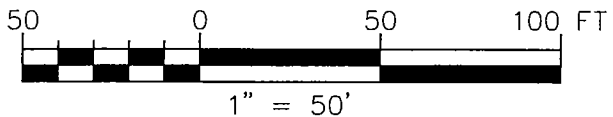

**YERRICK CREEK  
HYDROELECTRIC PROJECT**

**PENSTOCK COFFERDAM  
PLAN AND SECTION**

DATE: MARCH, 2010	
PROJECT NUMBER:	
SHEET NUMBER: <b>6</b>	ISSUE NO.: <b>A</b>

Applicant: Alaska Power and Telephone Company	File Number: POA-2009-445	Date: 30 April 2010
Attached is:	See Section below	
	INITIAL PROFFERED PERMIT (Standard Permit or Letter of Permission)	A
	PROFFERED PERMIT (Standard Permit or Letter of Permission)	B
	PERMIT DENIAL	C
XX	APPROVED JURISDICTIONAL DETERMINATION	D
	PRELIMINARY JURISDICTIONAL DETERMINATION	E

**THIS REQUEST FOR APPEAL FORM MUST BE RECEIVED BY: 29 JUNE 2010**

**SECTION I:** The following identifies your rights and options regarding an administrative appeal of the above decision. Additional information may be found at: <http://usace.army.mil/inet/functions/cw/cecw/req-or-Corps/regulations-at-33-CFR-Part-351>.

**A: INITIAL PROFFERED PERMIT:** You may accept or object to the permit.

- **ACCEPT:** If you received a Standard Permit, you may sign the permit document and return it to the District Engineer for final authorization. If you received a Letter of Permission (LOP), you may accept the LOP and your work is authorized. Your signature on the Standard Permit or acceptance of the LOP means that you accept the permit in its entirety, and waive all rights to appeal the permit, including its terms and conditions, and approved jurisdictional determinations associated with the permit.
- **OBJECT:** If you object to the permit (Standard or LOP) because of certain terms and conditions therein, you may request that the permit be modified accordingly. You must complete Section II of this form and return the form to the District Engineer. Your objections must be received by the District Engineer within 60 days of the date of this notice, or you will forfeit your right to appeal the permit in the future. Upon receipt of your letter, the District Engineer will evaluate your objections and may: (a) modify the permit to address all of your concerns, (b) modify the permit to address some of your objections, or, (c) not modify the permit, having determined that the permit should be issued as previously written. After evaluating your objections, the District Engineer will send you a proffered permit for your reconsideration, as indicated in Section B below.

**B: PROFFERED PERMIT:** You may accept or appeal the permit

- **ACCEPT:** If you received a Standard Permit, you may sign the permit document and return it to the District Engineer for final authorization. If you received a Letter of Permission (LOP), you may accept the LOP and your work is authorized. Your signature on the Standard Permit or acceptance of the LOP means that you accept the permit in its entirety, and waive all rights to appeal the permit, including its terms and conditions, and approved jurisdictional determinations associated with the permit.
- **APPEAL:** If you choose to decline the proffered permit (Standard or LOP) because of certain terms and conditions therein, you may appeal the declined permit under the Corps of Engineers Administrative Appeal Process by completing Section II of this form and sending the form to the Division Engineer. This form must be received by the Division Engineer within 60 days of the date of this notice.

**C: PERMIT DENIAL:** You may appeal the denial of a permit under the Corps of Engineers Administrative Appeal Process by completing Section II of this form and sending the form to the Division Engineer. This form must be received by the Division Engineer within 60 days of the date of this notice.

**D: APPROVED JURISDICTIONAL DETERMINATION (JD):** You may accept or appeal the approved JD or provide new information.

- **ACCEPT:** You do not need to notify the Corps to accept an approved JD. Failure to notify the Corps within 60 days of the date of this notice means that you accept the approved JD in its entirety, and waive all rights to appeal the approved JD.
- **APPEAL:** If you disagree with the approved JD, you may appeal the approved JD under the Corps of Engineers Administrative Appeal Process by completing Section II of this form and sending the form to the Division Engineer. This form must be received by the Division Engineer within 60 days of the date of this notice.

**E: PRELIMINARY JURISDICTIONAL DETERMINATION:** You do not need to respond to the Corps regarding the Preliminary JD. The Preliminary JD is not appealable. If you wish, you may request an approved JD (which may be appealed), by contacting the Corps district for further instruction. Also, you may provide new information for further consideration by the Corps to reevaluate the JD.

**SECTION II - REQUEST FOR APPEAL or OBJECTIONS TO AN INITIAL PROFFERED PERMIT**

**REASONS FOR APPEAL OR OBJECTIONS:** (Describe your reasons for appealing the decision or your objections to an initial proffered permit in clear concise statements. You may attach additional information to this form to clarify where your reasons or objections are addressed in the administrative record.)

**ADDITIONAL INFORMATION:** The appeal is limited to a review of the administrative record, the Corps memorandum for the record of the appeal conference or meeting, and any supplemental information that the review officer has determined is needed to clarify the administrative record. Neither the appellant nor the Corps may add new information or analyses to the record. However, you may provide additional information to clarify the location of information that is already in the administrative record.

In order for a Request For Appeal to be accepted by the Corps, the Corps must determine that it is complete, that it meets the criteria for appeal under 33 CFR Part 331.5, and that it has been received by the Division Office within 60 days of the date of the Notice of Appeal Process. It is not necessary to submit a Request For Appeal form to the Division office if you do not object to the decision.

**POINT OF CONTACT FOR QUESTIONS OR INFORMATION:**

If you have questions regarding this decision and/or the appeal process you may contact:

Harry A. Baij Jr.  
Alaska District Corps of Engineers  
Regulatory Division, CEPOA-RD-N  
Post Office Box 6896  
Elmendorf AFB, AK 99506-6898  
907-753-2784  
harry.a.baij@usace.army.mil

If you only have questions regarding the appeal process you may also contact:

Commander  
USAED, Pacific Ocean Division  
ATTN: CEPOD-PDC/Linda Hihara-Endo, P.E.  
Building 525  
Fort Shafter, HI 96858-5440

**To submit this form, mail to the address above**

**RIGHT OF ENTRY:** Your signature below grants the right of entry to Corps of Engineers personnel, and any government consultants, to conduct investigations of the project site during the course of the appeal process. You will be provided a 15-day notice of any site investigation, and will have the opportunity to participate in all site investigations.

\_\_\_\_\_  
Signature of appellant or agent.

Date:

Telephone number:

1. Navigation. (a) No activity may cause more than a minimal adverse effect on navigation.

(b) Any safety lights and signals prescribed by the U.S. Coast Guard, through regulations or otherwise, must be installed and maintained at the permittee's expense on authorized facilities in navigable waters of the United States.

(c) The permittee understands and agrees that, if future operations by the United States require the removal, relocation, or other alteration, of the structure or work herein authorized, or if, in the opinion of the Secretary of the Army or his authorized representative, said structure or work shall cause unreasonable obstruction to the free navigation of the navigable waters, the permittee will be required, upon due notice from the Corps of Engineers, to remove, relocate, or alter the structural work or obstructions caused thereby, without expense to the United States. No claim shall be made against the United States on account of any such removal or alteration.

2. Aquatic Life Movements. No activity may substantially disrupt the necessary life cycle movements of those species of aquatic life indigenous to the waterbody, including those species that normally migrate through the area, unless the activity's primary purpose is to impound water. Culverts placed in streams must be installed to maintain low flow conditions.

3. Spawning Areas. Activities in spawning areas during spawning seasons must be avoided to the maximum extent practicable. Activities that result in the physical destruction (e.g., through excavation, fill, or downstream smothering by substantial turbidity) of an important spawning area are not authorized.

4. Migratory Bird Breeding Areas. Activities in waters of the United States that serve as breeding areas for migratory birds must be avoided to the maximum extent practicable.

5. Shellfish Beds. No activity may occur in areas of concentrated shellfish populations, unless the activity is directly related to a shellfish harvesting activity authorized by NWP 4 and 48.

6. Suitable Material. No activity may use unsuitable material (e.g., trash, debris, car bodies, asphalt, etc.). Material used for construction or discharged must be free from toxic pollutants in toxic amounts (see Section 307 of the Clean Water Act).

7. Water Supply Intakes. No activity may occur in the proximity of a public water supply intake, except where the activity is for the repair or improvement of public water supply intake structures or adjacent bank stabilization.

8. Adverse Effects From Impoundments. If the activity creates an impoundment of water, adverse effects to the aquatic system due to accelerating the passage of water, and/or restricting its flow must be minimized to the maximum extent practicable.

9. Management of Water Flows. To the maximum extent practicable, the pre-construction course, condition, capacity, and location of open waters must be maintained for each activity, including stream channelization and storm water management activities, except as provided below. The activity must be constructed to withstand expected high flows. The activity must not restrict or impede the passage of normal or high flows, unless the primary purpose of the activity is to impound water or manage high flows. The activity may alter the pre-construction course, condition, capacity, and location of open waters if it benefits the aquatic environment (e.g., stream restoration or relocation activities).

10. Fills Within 100-Year Floodplains. The activity must comply with applicable FEMA-approved state or local floodplain management requirements.

11. Equipment. Heavy equipment working in wetlands or mudflats must be placed on mats, or other measures must be taken to minimize soil disturbance.

12. Soil Erosion and Sediment Controls. Appropriate soil erosion and sediment controls must be used and maintained in effective operating condition during construction, and all exposed soil and other fills, as well as any work below the ordinary high water mark or high tide line, must be permanently stabilized at the earliest practicable date. Permittees are encouraged to perform work within waters of the United States during periods of low-flow or no-flow.

13. Removal of Temporary Fills. Temporary fills must be removed in their entirety and the affected areas returned to pre-construction elevations. The affected areas must be revegetated, as appropriate.

14. Proper Maintenance. Any authorized structure or fill shall be properly maintained, including maintenance to ensure public safety.

15. Wild and Scenic Rivers. No activity may occur in a component of the National Wild and Scenic River System, or in a river officially designated by Congress as a "study river" for possible inclusion in the system while the river is in an official study status, unless the appropriate Federal agency with direct management responsibility for such river, has determined in writing that the proposed activity will not adversely affect the Wild and Scenic River designation or study status. Information on Wild and Scenic Rivers may be obtained from the appropriate Federal land management agency in the area (e.g., National Park Service, U.S. Forest Service, Bureau of Land Management, U.S. Fish and Wildlife Service).

16. Tribal Rights. No activity or its operation may impair reserved tribal rights, including, but not limited to, reserved water rights and treaty fishing and hunting rights.

17. Endangered Species. (a) No activity is authorized under any NWP which is likely to jeopardize the continued existence of a threatened or endangered species or a species proposed for such designation, as identified under the Federal Endangered



Species Act (ESA), or which will destroy or adversely modify the critical habitat of such species. No activity is authorized under any NWP which “may affect” a listed species or critical habitat, unless Section 7 consultation addressing the effects of the proposed activity has been completed.

(b) Federal agencies should follow their own procedures for complying with the requirements of the ESA. Federal permittees must provide the district engineer with the appropriate documentation to demonstrate compliance with those requirements.

(c) Non-federal permittees shall notify the district engineer if any listed species or designated critical habitat might be affected or is in the vicinity of the project, or if the project is located in designated critical habitat, and shall not begin work on the activity until notified by the district engineer that the requirements of the ESA have been satisfied and that the activity is authorized. For activities that might affect Federally-listed endangered or threatened species or designated critical habitat, the pre-construction notification must include the name(s) of the endangered or threatened species that may be affected by the proposed work or that utilize the designated critical habitat that may be affected by the proposed work. The district engineer will determine whether the proposed activity “may affect” or will have “no effect” to listed species and designated critical habitat and will notify the non-Federal applicant of the Corps’ determination within 45 days of receipt of a complete pre-construction notification. In cases where the non-Federal applicant has identified listed species or critical habitat that might be affected or is in the vicinity of the project, and has so notified the Corps, the applicant shall not begin work until the Corps has provided notification the proposed activities will have “no effect” on listed species or critical habitat, or until Section 7 consultation has been completed.

(d) As a result of formal or informal consultation with the FWS or NMFS the district engineer may add species-specific regional endangered species conditions to the NWPs.

(e) Authorization of an activity by a NWP does not authorize the “take” of a threatened or endangered species as defined under the ESA. In the absence of separate authorization (e.g., an ESA Section 10 Permit, a Biological Opinion with “incidental take” provisions, etc.) from the U.S. FWS or the NMFS, both lethal and non-lethal “takes” of protected species are in violation of the ESA. Information on the location of threatened and endangered species and their critical habitat can be obtained directly from the offices of the U.S. FWS and NMFS or their world wide Web pages at <http://www.fws.gov/> and <http://www.noaa.gov/fisheries.html> respectively.

18. Historic Properties. (a) In cases where the district engineer determines that the activity may affect properties listed, or eligible for listing, in the National Register of Historic Places, the activity is not authorized, until the requirements of Section 106 of the National Historic Preservation Act (NHPA) have been satisfied.

(b) Federal permittees should follow their own procedures for complying with the requirements of Section 106 of the National Historic Preservation Act. Federal permittees must provide the district engineer with the appropriate documentation to demonstrate compliance with those requirements.

(c) Non-federal permittees must submit a pre-construction notification to the district engineer if the authorized activity may have the potential to cause effects to any

historic properties listed, determined to be eligible for listing on, or potentially eligible for listing on the National Register of Historic Places, including previously unidentified properties. For such activities, the pre-construction notification must state which historic properties may be affected by the proposed work or include a vicinity map indicating the location of the historic properties or the potential for the presence of historic properties. Assistance regarding information on the location of or potential for the presence of historic resources can be sought from the State Historic Preservation Officer or Tribal Historic Preservation Officer, as appropriate, and the National Register of Historic Places (see 33 CFR 330.4(g)). The district engineer shall make a reasonable and good faith effort to carry out appropriate identification efforts, which may include background research, consultation, oral history interviews, sample field investigation, and field survey. Based on the information submitted and these efforts, the district engineer shall determine whether the proposed activity has the potential to cause an effect on the historic properties. Where the non-Federal applicant has identified historic properties which the activity may have the potential to cause effects and so notified the Corps, the non-Federal applicant shall not begin the activity until notified by the district engineer either that the activity has no potential to cause effects or that consultation under Section 106 of the NHPA has been completed.

(d) The district engineer will notify the prospective permittee within 45 days of receipt of a complete pre-construction notification whether NHPA Section 106 consultation is required. Section 106 consultation is not required when the Corps determines that the activity does not have the potential to cause effects on historic properties (see 36 CFR §800.3(a)). If NHPA section 106 consultation is required and will occur, the district engineer will notify the non-Federal applicant that he or she cannot begin work until Section 106 consultation is completed.

(e) Prospective permittees should be aware that section 110k of the NHPA (16 U.S.C. 470h-2(k)) prevents the Corps from granting a permit or other assistance to an applicant who, with intent to avoid the requirements of Section 106 of the NHPA, has intentionally significantly adversely affected a historic property to which the permit would relate, or having legal power to prevent it, allowed such significant adverse effect to occur, unless the Corps, after consultation with the Advisory Council on Historic Preservation (ACHP), determines that circumstances justify granting such assistance despite the adverse effect created or permitted by the applicant. If circumstances justify granting the assistance, the Corps is required to notify the ACHP and provide documentation specifying the circumstances, explaining the degree of damage to the integrity of any historic properties affected, and proposed mitigation. This documentation must include any views obtained from the applicant, SHPO/THPO, appropriate Indian tribes if the undertaking occurs on or affects historic properties on tribal lands or affects properties of interest to those tribes, and other parties known to have a legitimate interest in the impacts to the permitted activity on historic properties.

19. Designated Critical Resource Waters. Critical resource waters include, NOAA-designated marine sanctuaries, National Estuarine Research Reserves, state natural heritage sites, and outstanding national resource waters or other waters officially designated by a state as having particular environmental or ecological significance and identified by the district engineer after notice and opportunity for public comment. The

district engineer may also designate additional critical resource waters after notice and opportunity for comment.

(a) Discharges of dredged or fill material into waters of the United States are not authorized by NWP 7, 12, 14, 16, 17, 21, 29, 31, 35, 39, 40, 42, 43, 44, 49, and 50 for any activity within, or directly affecting, critical resource waters, including wetlands adjacent to such waters.

(b) For NWP 3, 8, 10, 13, 15, 18, 19, 22, 23, 25, 27, 28, 30, 33, 34, 36, 37, and 38, notification is required in accordance with general condition 27, for any activity proposed in the designated critical resource waters including wetlands adjacent to those waters. The district engineer may authorize activities under these NWPs only after it is determined that the impacts to the critical resource waters will be no more than minimal.

20. Mitigation. The district engineer will consider the following factors when determining appropriate and practicable mitigation necessary to ensure that adverse effects on the aquatic environment are minimal:

(a) The activity must be designed and constructed to avoid and minimize adverse effects, both temporary and permanent, to waters of the United States to the maximum extent practicable at the project site (i.e., on site).

(b) Mitigation in all its forms (avoiding, minimizing, rectifying, reducing, or compensating) will be required to the extent necessary to ensure that the adverse effects to the aquatic environment are minimal.

(c) Compensatory mitigation at a minimum one-for-one ratio will be required for all wetland losses that exceed 1/10 acre and require pre-construction notification, unless the district engineer determines in writing that some other form of mitigation would be more environmentally appropriate and provides a project-specific waiver of this requirement. For wetland losses of 1/10 acre or less that require pre-construction notification, the district engineer may determine on a case-by-case basis that compensatory mitigation is required to ensure that the activity results in minimal adverse effects on the aquatic environment. Since the likelihood of success is greater and the impacts to potentially valuable uplands are reduced, wetland restoration should be the first compensatory mitigation option considered.

(d) For losses of streams or other open waters that require pre-construction notification, the district engineer may require compensatory mitigation, such as stream restoration, to ensure that the activity results in minimal adverse effects on the aquatic environment.

(e) Compensatory mitigation will not be used to increase the acreage losses allowed by the acreage limits of the NWPs. For example, if an NWP has an acreage limit of 1/2 acre, it cannot be used to authorize any project resulting in the loss of greater than 1/2 acre of waters of the United States, even if compensatory mitigation is provided that replaces or restores some of the lost waters. However, compensatory mitigation can and should be used, as necessary, to ensure that a project already meeting the established acreage limits also satisfies the minimal impact requirement associated with the NWPs.

(f) Compensatory mitigation plans for projects in or near streams or other open waters will normally include a requirement for the establishment, maintenance, and legal protection (e.g., conservation easements) of riparian areas next to open waters. In some cases, riparian areas may be the only compensatory mitigation required. Riparian areas

should consist of native species. The width of the required riparian area will address documented water quality or aquatic habitat loss concerns. Normally, the riparian area will be 25 to 50 feet wide on each side of the stream, but the district engineer may require slightly wider riparian areas to address documented water quality or habitat loss concerns. Where both wetlands and open waters exist on the project site, the district engineer will determine the appropriate compensatory mitigation (e.g., riparian areas and/or wetlands compensation) based on what is best for the aquatic environment on a watershed basis. In cases where riparian areas are determined to be the most appropriate form of compensatory mitigation, the district engineer may waive or reduce the requirement to provide wetland compensatory mitigation for wetland losses.

(g) Permittees may propose the use of mitigation banks, in-lieu fee arrangements or separate activity-specific compensatory mitigation. In all cases, the mitigation provisions will specify the party responsible for accomplishing and/or complying with the mitigation plan.

(h) Where certain functions and services of waters of the United States are permanently adversely affected, such as the conversion of a forested or scrub-shrub wetland to a herbaceous wetland in a permanently maintained utility line right-of-way, mitigation may be required to reduce the adverse effects of the project to the minimal level.

21. Water Quality. Where States and authorized Tribes, or EPA where applicable, have not previously certified compliance of an NWP with CWA Section 401, individual 401 Water Quality Certification must be obtained or waived (see 33 CFR 330.4(c)). The district engineer or State or Tribe may require additional water quality management measures to ensure that the authorized activity does not result in more than minimal degradation of water quality.

22. Coastal Zone Management. In coastal states where an NWP has not previously received a state coastal zone management consistency concurrence, an individual state coastal zone management consistency concurrence must be obtained, or a presumption of concurrence must occur (see 33 CFR 330.4(d)). The district engineer or a State may require additional measures to ensure that the authorized activity is consistent with state coastal zone management requirements.

23. Regional and Case-By-Case Conditions. The activity must comply with any regional conditions that may have been added by the Division Engineer (see 33 CFR 330.4(e)) and with any case specific conditions added by the Corps or by the state, Indian Tribe, or U.S. EPA in its section 401 Water Quality Certification, or by the state in its Coastal Zone Management Act consistency determination.

24. Use of Multiple Nationwide Permits. The use of more than one NWP for a single and complete project is prohibited, except when the acreage loss of waters of the United States authorized by the NWPs does not exceed the acreage limit of the NWP with the highest specified acreage limit. For example, if a road crossing over tidal waters is constructed under NWP 14, with associated bank stabilization authorized by NWP 13,

the maximum acreage loss of waters of the United States for the total project cannot exceed 1/3-acre.

25. Transfer of Nationwide Permit Verifications. If the permittee sells the property associated with a nationwide permit verification, the permittee may transfer the nationwide permit verification to the new owner by submitting a letter to the appropriate Corps district office to validate the transfer. A copy of the nationwide permit verification must be attached to the letter, and the letter must contain the following statement and signature:

“When the structures or work authorized by this nationwide permit are still in existence at the time the property is transferred, the terms and conditions of this nationwide permit, including any special conditions, will continue to be binding on the new owner(s) of the property. To validate the transfer of this nationwide permit and the associated liabilities associated with compliance with its terms and conditions, have the transferee sign and date below.”

---

(Transferee)

---

(Date)

26. Compliance Certification. Each permittee who received an NWP verification from the Corps must submit a signed certification regarding the completed work and any required mitigation. The certification form must be forwarded by the Corps with the NWP verification letter and will include:

- (a) A statement that the authorized work was done in accordance with the NWP authorization, including any general or specific conditions;
- (b) A statement that any required mitigation was completed in accordance with the permit conditions; and
- (c) The signature of the permittee certifying the completion of the work and mitigation.

27. Pre-Construction Notification. This general condition requires the applicant to provide notification (except for NWPs # 1, 2, 4, 5, 6, 9, 10, 11, 15, 16, 19, 20, 24, 25, 28, 30, 32, 35, and 47) to the District Engineer, including project-specific information, before DA authorization can be granted. The District Engineer reviews that information and solicits input from federal, state, and local resource agencies before making a permit decision. Once authorization has been granted, there are no further requirements of this general condition; therefore, the text of this condition has been removed. A copy of the full text will be provided upon request (visit our web site at: [www.poa.usace.army.mil/reg](http://www.poa.usace.army.mil/reg))."

28. Single and Complete Project. The activity must be a single and complete project. The same NWP cannot be used more than once for the same single and complete project.

## **Regional Conditions for the Alaska District**

### **REGIONAL CONDITION A - Additional Pre-Construction Notification (PCN) Requirements<sup>1</sup>**

1. NWP 6, Survey Activities: 3-D seismic surveys employing ocean bottom cables.
2. NWP 13, Bank Stabilization: Projects require a PCN when specified by NWP 13 and/or the proposed methods and techniques are not included in Streambank Revegetation and Protection: A Guide for Alaska Revised 2005 (Walter, Hughes and Moore, April 2005) (Guide) or its future revisions.

The Guide is available at <http://www.sf.adfg.state.ak.us/sarr/restoration/techniques/techniques.cfm>

Furthermore, applicants proposing projects not contained in the Guide may still qualify for NWP 13 but they shall provide an alternative analysis to the district engineer with the PCN consisting of the bioengineered methods that were considered and rationale as to why these alternatives are not in the applicant's preferred alternative. Applicants subject to the PCN due to a design that is not included in the Guide are encouraged to include measures that minimize impacts to the aquatic environment including methods that improve fish habitat such as vegetated riprap.

3. Any activity proposing pile driving in the following Navigable (Section 10) waters: marine waters, anadromous lakes or anadromous streams.

<sup>1</sup> Where required by the terms of the NWP or Regional Condition A, a prospective permittee must notify the district engineer by submitting a preconstruction notification (PCN) as early as possible. See General Condition 27 of the NWPs for the contents of the PCN or visit [www.poa.usace.army.mil/reg/NWPs](http://www.poa.usace.army.mil/reg/NWPs). This Regional Condition does not apply to NWP 47.

### **REGIONAL CONDITION B – General Permit Agency Coordination**

*This Regional Condition establishes geographic and habitat areas that will require agency coordination for projects that are less than 1/2 acre.<sup>1</sup>*

For projects requiring a Pre-Construction Notification (PCN) and occurring within any of the following geographic/habitat areas, the Corps will conduct agency coordination with the appropriate agencies according to General Condition No.27, regardless of the amount of loss of waters of the U.S.

- 1) The Municipality of Anchorage.
- 2) Areas designated as "A" or "B" wetlands in the Juneau Wetlands Management Plan.
- 3) Areas designated as "High" or "Moderate" value wetlands in the Homer Wetland Functional Assessment.
- 4) Anadromous lakes or anadromous streams including, but not limited to catalogued streams identified in the *Catalog of Waters Important for the Spawning, Rearing, or Migration of Anadromous Fishes* (available at <http://www.sf.adfg.state.ak.us/SARR/FishDistrib/anadcat.cfm>)
- 5) Jurisdictional areas within 500 feet (measured from OHW or HTL) of anadromous lakes or anadromous streams as identified above.
- 6) Marine waters.

Local, State or Federal applicants may choose to conduct agency coordination in accordance with this regional condition for projects in the above geographic areas having less than 1/2 acre loss of waters of the U.S. The documentation of agency coordination shall be supplied with the PCN and if the Corps determines the applicant's proposal adequately addresses agency concerns, the project will not be coordinated again.

The Corps (or local, State or Federal applicant, as described above) will coordinate such projects with the Environmental Protection Agency, U.S. Fish and Wildlife Service, National Marine Fisheries Service and State Historical Preservation Officer or Tribal Historical Preservation Officer. Additionally, project coordination will occur with the State of Alaska's Department of Natural Resources, Office of Project Management and Permitting for projects that are within the coastal zone or when outside the coastal

## **Regional Conditions for the Alaska District**

zone, coordination will occur with the Department of Environmental Conservation, the State of Alaska's Department of Natural Resources, Office of Habitat Management and Permitting, and the Department of Fish and Game for activities within State Refuges, Critical Habitat Areas and Sanctuaries.

<sup>1</sup> For activities requiring a PCN that result in the loss of greater than 1/2-acre of waters of the U.S., agency coordination will occur according to general condition 27(d) but also include the agencies as specified above.

### **REGIONAL CONDITION C - Wood Preservatives**

*This Regional Condition applies to all NWP's when the regulated activity involves the use of wood preservative products in waters of the U.S.<sup>1</sup>*

1. For new materials<sup>2</sup>:

- a) Preservatives for wooden structures shall be applied by pressure treatment.
- b) In fresh waters, wood structures treated with creosote or pentachlorophenol preservative shall not be used.
- c) In marine waters, wood structures treated with pentachlorophenol preservative shall not be used.

2. For the reuse of previously treated wood products in marine waters the wood preservative product's use shall be consistent with its original use and may not be treated with any additional wood preservative. (e.g. the reuse for dock piling of creosote treated wood for dock piling is allowable, the reuse for a retaining wall of creosote treated railroad ties is not allowed, etc.).

<sup>1</sup> Wood preservative products allowed for use in the aquatic/marine environments is determined by the Environmental Protection Agency.

<sup>2</sup>Treated wood products are produced and installed in accordance with the "Best Management Practices for the Use of Treated Wood in Aquatic and Other Sensitive Environments" (August 2006), including amendments published by the Western Wood Preservers Institute (WWPI) ([www.wwpinstitute.org](http://www.wwpinstitute.org)) including the standards set forth by the American Wood-Preservers Association (AWPA) ([www.awpa.com](http://www.awpa.com)), the Timber Piling Council (TPC) ([www.timberpilingcouncil.org](http://www.timberpilingcouncil.org)) and/or the American Lumber Standards Committee as appropriate.

### **REGIONAL CONDITION D - Activities Involving Trenching**

Trenches cannot be constructed or backfilled in such a manner as to drain waters of the U.S. (e.g., backfilling with extensive gravel layers, creating a french drain effect). Ditch plugs or other methods shall be used to prevent this situation.

Except for material placed as minor trench over-fill or surcharge necessary to offset subsidence or compaction, all excess materials shall be removed to a non-wetland location. The backfilled trench shall achieve the original surface condition, within a year of disturbance unless climatic conditions warrant additional time and is approved by the Corps.

Revegetation of the trench should follow the process outlined in RC E.

### **REGIONAL CONDITION E - Site Restoration for Projects with Ground Disturbing Activities**

Disturbed areas shall be stabilized immediately after construction to prevent erosion. Revegetation of the site shall begin as soon as site conditions allow and in the same growing season as the disturbance unless climatic conditions warrant additional time and is approved by the Corps. Native vegetation and



## **Regional Conditions for the Alaska District**

soils removed for project construction shall be stockpiled separately and used for site rehabilitation. If soil and/or organic materials are not available from the project site for rehabilitation, other locally-obtained native materials may be used. Other topsoil or organic materials (including seed) may be used only if identified in the PCN and approved in the NWP verification. Species to be used for seeding and planting shall follow this order of preference: 1) species native to the site; 2) species native to the area; 3) species native to the state. Revegetated areas eventually shall have enough cover to sufficiently control erosion without silt fences, hay bales, or other mechanical means.

### **REGIONAL CONDITION F - Equipment Standards**

Heavy equipment working in wetlands or mudflats must be placed on mats, or other measures (e.g. ice roads, compacted snow, low psi ground bearing weight, etc) must be taken to prevent soil disturbance.

### **REGIONAL CONDITIONS G - J APPLY TO SPECIFIC NWPs.**

#### **REGIONAL CONDITION G- Seasonal Docks Authorized by NWP 11, Temporary Recreational Structures**

Small, seasonal docks shall not extend more than 50 feet waterward of the ordinary high water mark or mean high water mark, or exceed more than 25 percent of the width of the waterbody, whichever is less.

#### **REGIONAL CONDITION H – NWP 40 Agricultural Activities**

The following activities are not authorized by NWP 40: a. Drain tiles, ditches, or levees or; b. Mechanized land clearing and land leveling in jurisdictional wetlands within 500' of anadromous lakes or anadromous streams.

#### **REGIONAL CONDITION I – NWP 44 Mining Activities**

Placer mining activities are excluded from coverage by NWP 44 (Mining Activities). Placer mining may be authorized by Regional General Permit 2006-1944. In Alaska, NWP 44 will only authorize the following activities:

1. Hard rock mining, not including trenching, drilling, or access road construction. Applicable to Section 404 only.
2. Temporary stockpiling of sand and gravel in waters of the U.S., limited to seasonally dewatered unvegetated sand/gravel bars. Stockpiles shall be completely removed and the area restored to pre-project contours within one year, in advance of seasonal ordinary high water events, and/or prior to equipment being removed from site, whichever comes first.

#### **REGIONAL CONDITION J – NWP 48 Existing Commercial Shellfish Aquaculture Activities**

NWP 48 is revoked in Alaska. Applicants seeking authorization for this work are encouraged to apply for Regional General Permit 1991-7-P, Mariculture Activities in Alaska.

(BLANK PAGE)

# ALASKA POWER & TELEPHONE COMPANY

P.O. BOX 3222 • 193 OTTO STREET  
PORT TOWNSEND, WA 98368  
(360) 385-1733 • (800) 982-0136  
FAX (360) 385-5177

April 7, 2010

Robert F. "Mac" McLean  
Regional Supervisor  
Division of Habitat  
Alaska Department of Fish & Game  
1300 College Road  
Fairbanks, AK 99701-1551

Re: Yerrick Creek Hydroelectric Project  
Fish Habitat Permit FH09-III-0182

Dear Mr. McLean:

In response to your March 5, 2010, letter to update you on the overall project status, we offer the following:

We are still acquiring funding for the project and therefore may not break ground this year. No changes to the project scope have occurred, but we have chosen our preferred route that avoids wetlands but does cross the creek with a single-lane bridge, for which two concrete pilings will be placed in the floodplain to span the creek.

Enclosed is a diagram of the final penstock and access road route, diversion plan and profile views, as well as other diagrams regarding how features will be constructed in the creek.

If further information is needed, please let us know.

Sincerely,

A handwritten signature in cursive script that reads "Glen D. Martin". The signature is written in black ink and is positioned above the typed name and title.

Glen D. Martin  
Project Manager  
(360) 385-1733 x122  
[glen.m@aptalaska.com](mailto:glen.m@aptalaska.com)

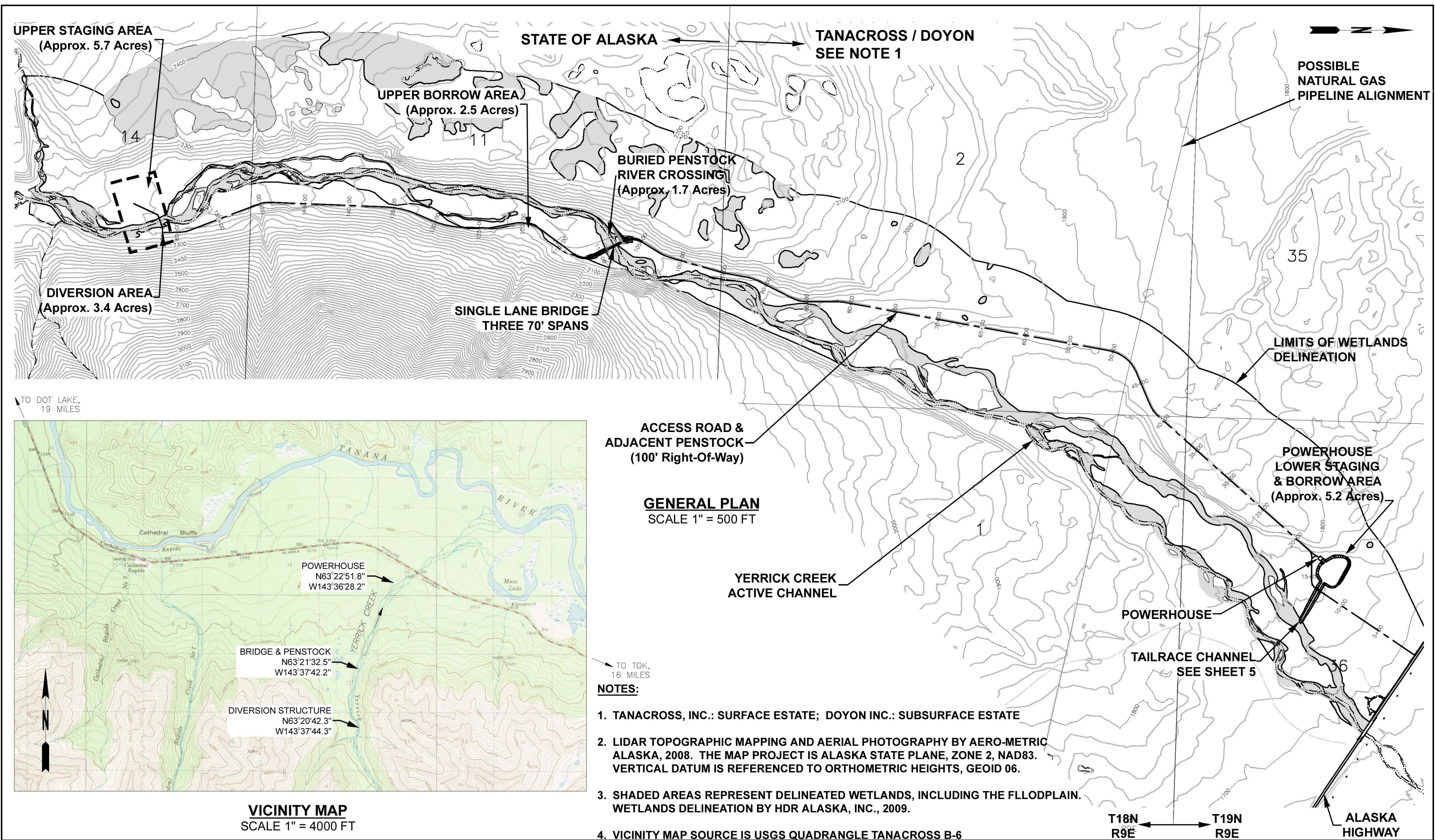

TO DOT LAKE,  
19 MILES

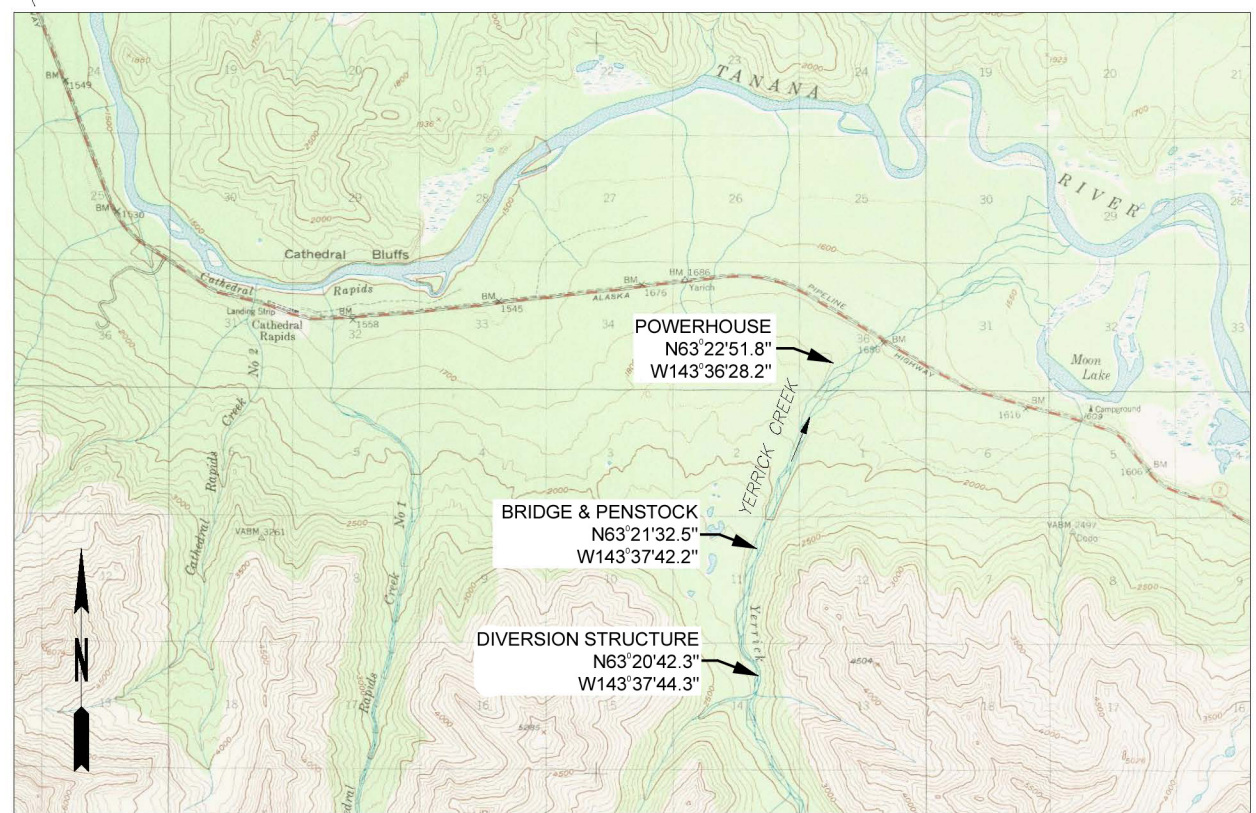

**VICINITY MAP**  
SCALE 1" = 4000 FT

ACCESS ROAD &  
ADJACENT PENSTOCK  
(100' Right-Of-Way)

**GENERAL PLAN**  
SCALE 1" = 500 FT

YERRICK CREEK  
ACTIVE CHANNEL

TO TOK,  
16 MILES

**NOTES:**

1. TANACROSS, INC.: SURFACE ESTATE; DOYON INC.: SUBSURFACE ESTATE
2. LIDAR TOPOGRAPHIC MAPPING AND AERIAL PHOTOGRAPHY BY AERO-METRIC ALASKA, 2008. THE MAP PROJECT IS ALASKA STATE PLANE, ZONE 2, NAD83. VERTICAL DATUM IS REFERENCED TO ORTHOMETRIC HEIGHTS, GEOID 06.
3. SHADED AREAS REPRESENT DELINEATED WETLANDS, INCLUDING THE FLOODPLAIN. WETLANDS DELINEATION BY HDR ALASKA, INC., 2009.
4. VICINITY MAP SOURCE IS USGS QUADRANGLE TANACROSS B-6

T18N  
R9E

T19N  
R9E

ALASKA  
HIGHWAY

ISSUE NO.	DATE	DESCRIPTION	BY	CHK	APPR	CHECKED:

HALF-SIZE DRAWING

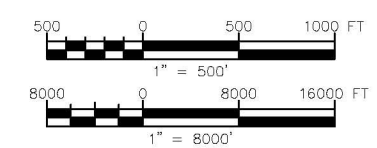

**YERRICK CREEK  
HYDROELECTRIC PROJECT**

**GENERAL PLAN AND  
VICINITY MAP**

DATE:	JANUARY, 2010
PROJECT NUMBER:	
SHEET NUMBER:	1
ISSUE NO.:	

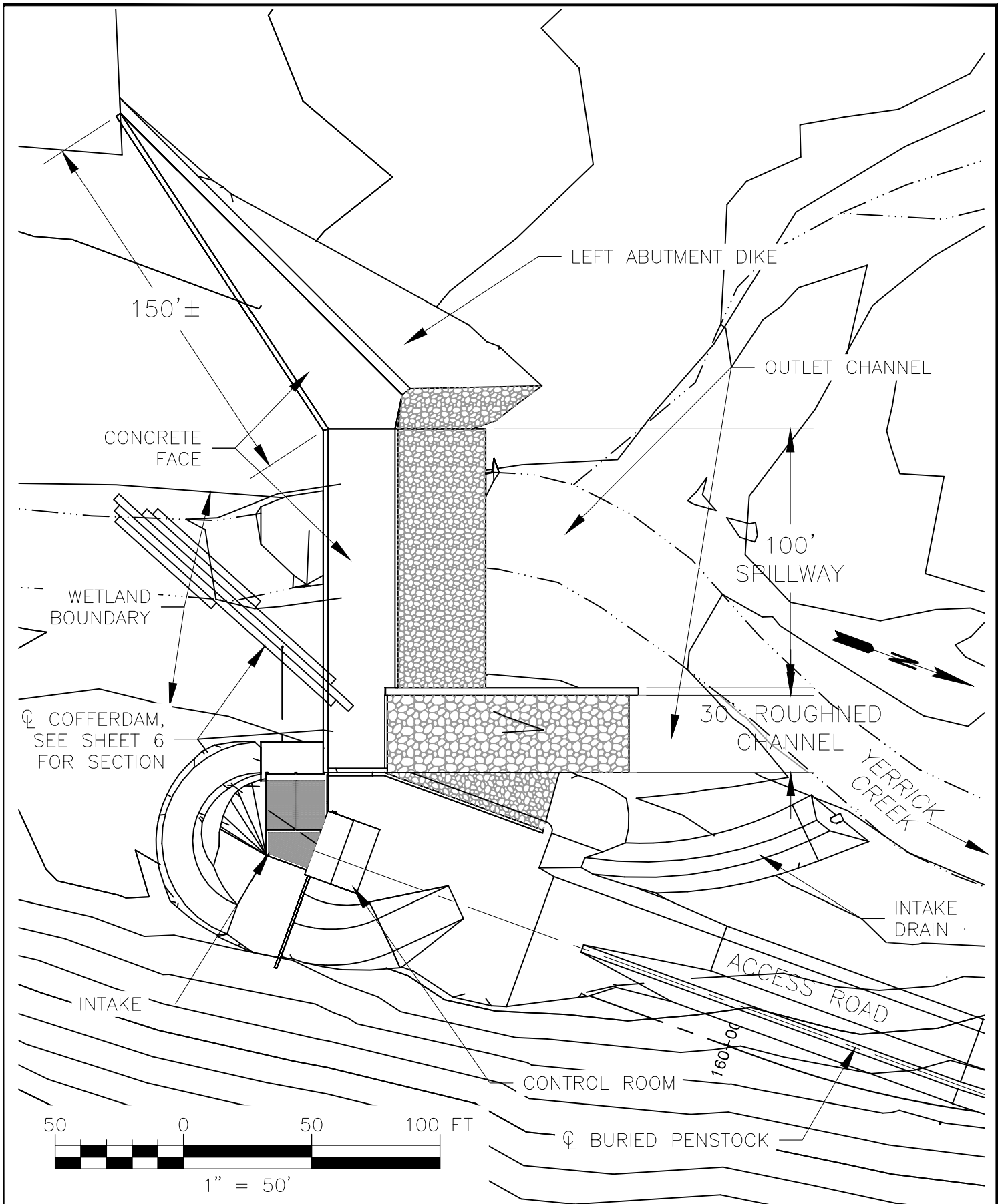

**AP&T**  
 ALASKA POWER &  
 TELEPHONE COMPANY

**YERRICK CREEK  
 HYDROELECTRIC PROJECT**  
**INTAKE STRUCTURE  
 PLAN**

DATE: MARCH, 2010	
PROJECT NUMBER:	
SHEET NUMBER: <b>2</b>	ISSUE NO. <b>B</b>

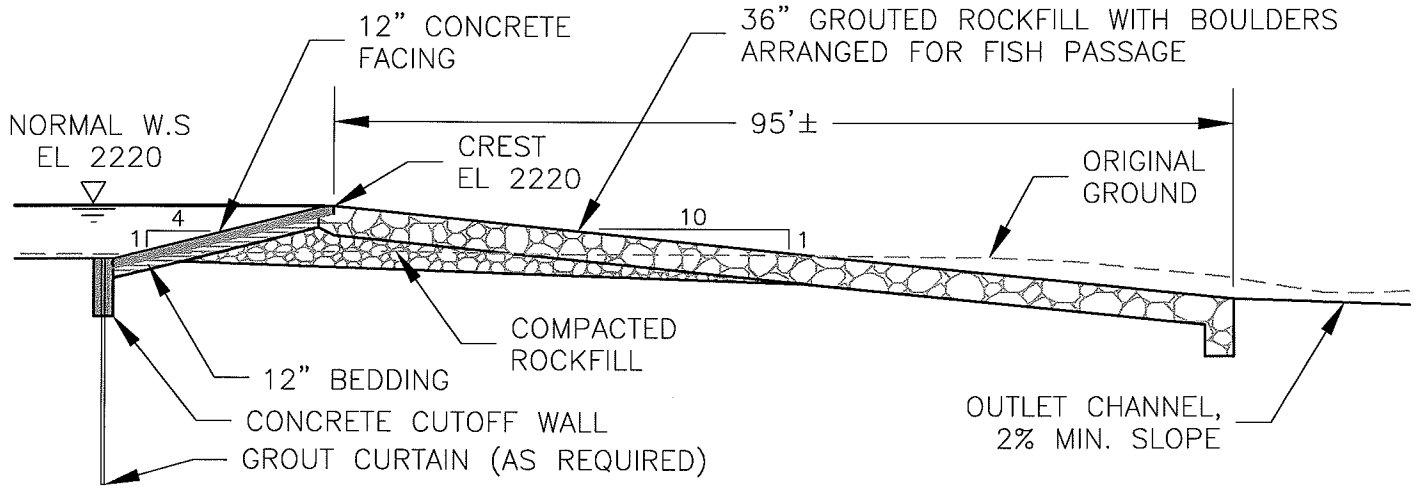

**ROUGHENED CHANNEL SECTION**

SCALE 1"=20'

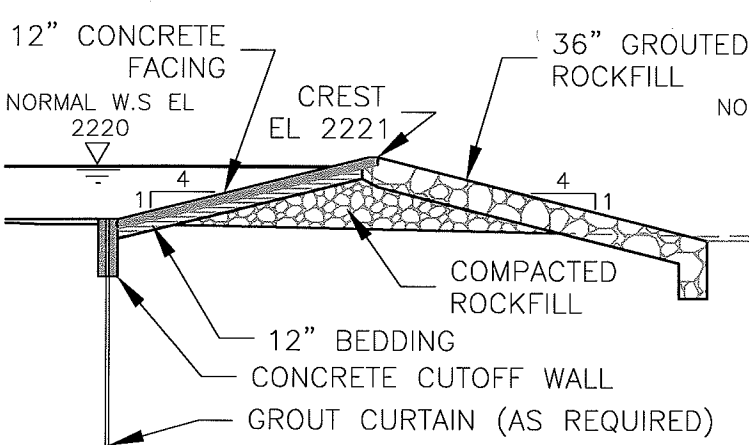

**SPILLWAY SECTION**

SCALE 1"=20'

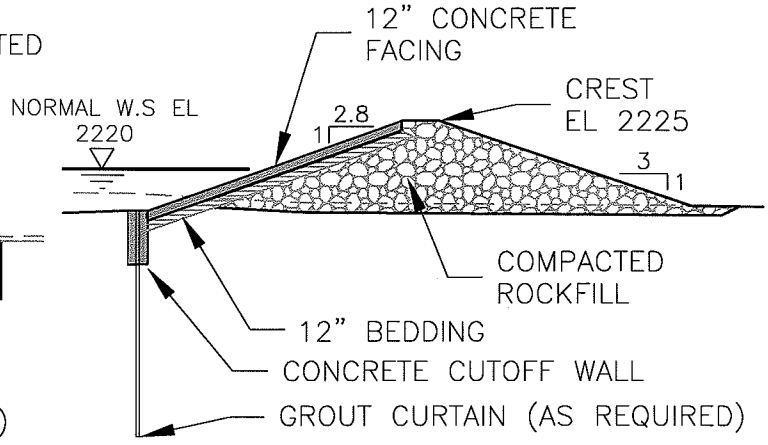

**LEFT ABUTMENT DIKE SECTION**

SCALE 1"=20'

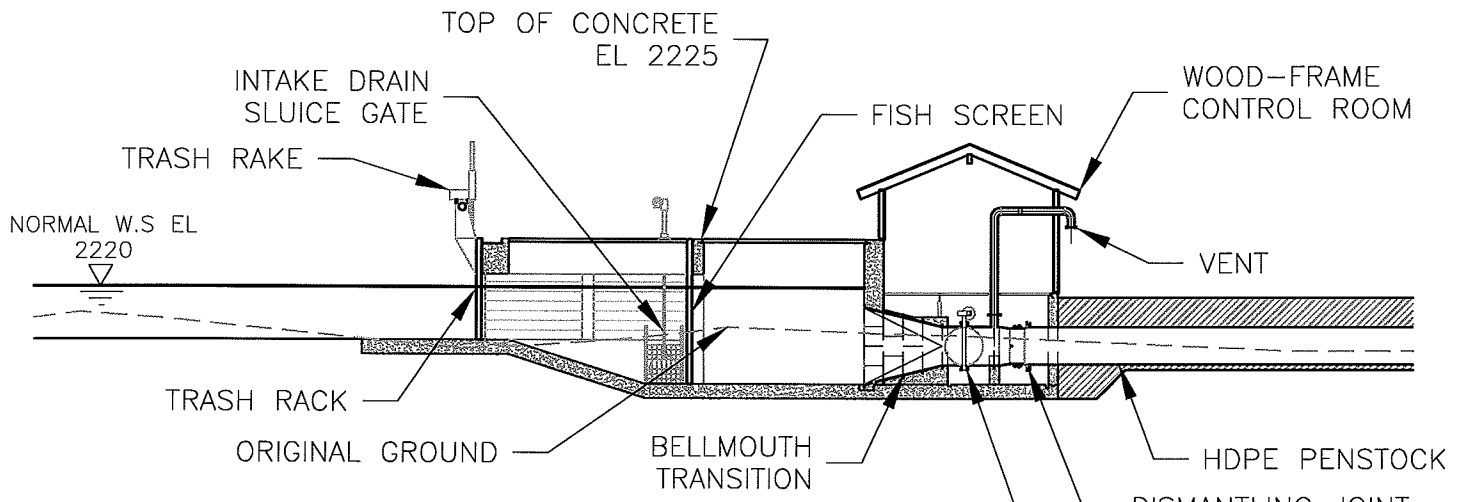

**INTAKE SECTION**

SCALE 1"=20'

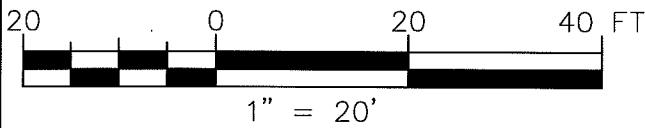

**YERRICK CREEK  
HYDROELECTRIC PROJECT**

**INTAKE STRUCTURE  
SECTIONS**

DATE: JANUARY, 2010	
PROJECT NUMBER:	
SHEET NUMBER:	ISSUE NO.
<b>3</b>	

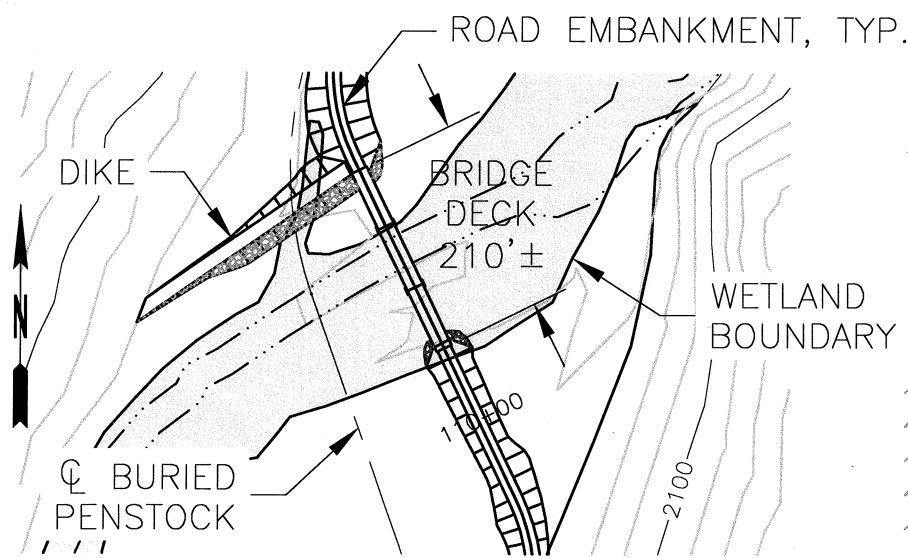

**BRIDGE AND PENSTOCK PLAN**

SCALE 1"=200'

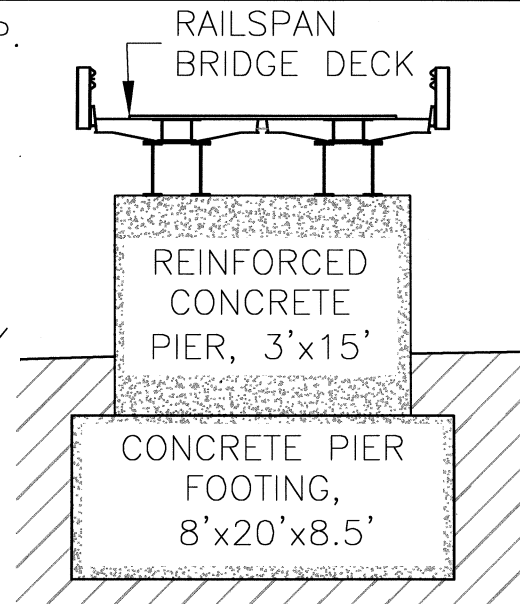

**BRIDGE SECTION**

SCALE 1"=10'

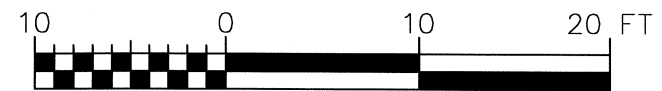

1" = 10'

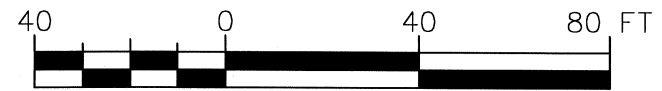

1" = 40'

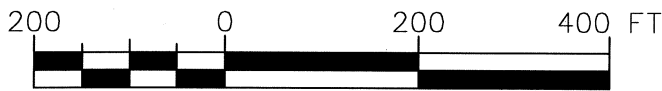

1" = 200'

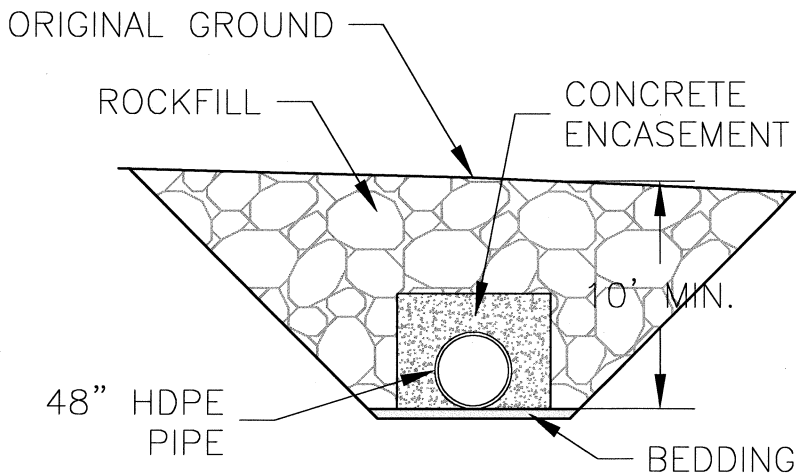

**BURIED PENSTOCK SECTION**

SCALE 1"=10'

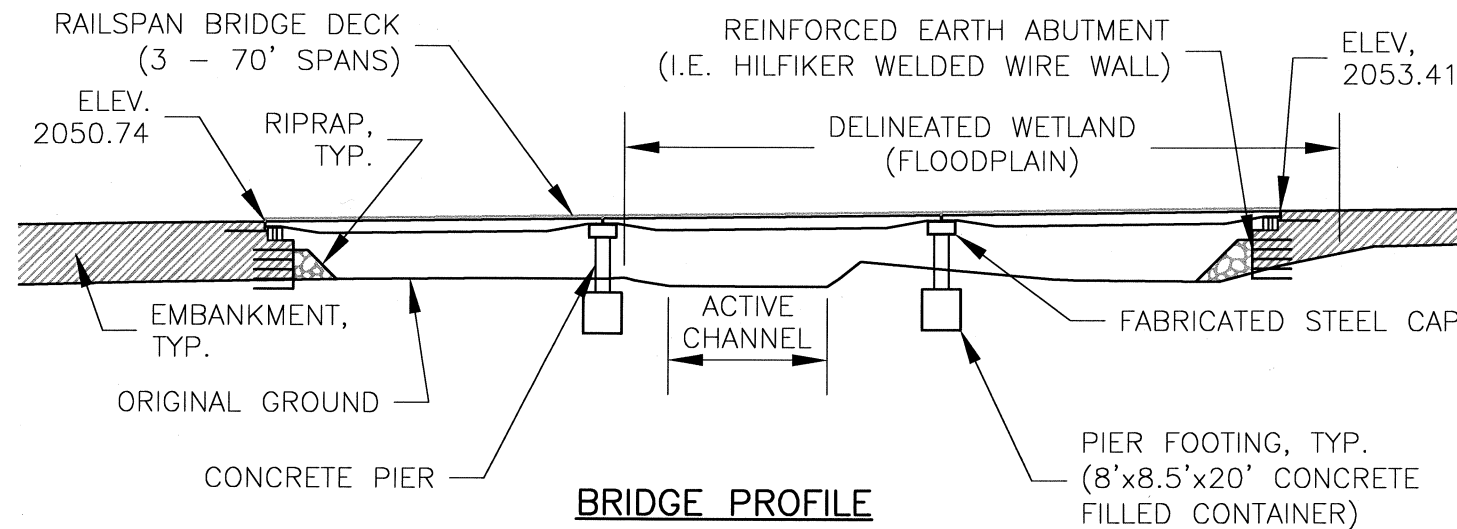

**BRIDGE PROFILE**

SCALE 1"=40'

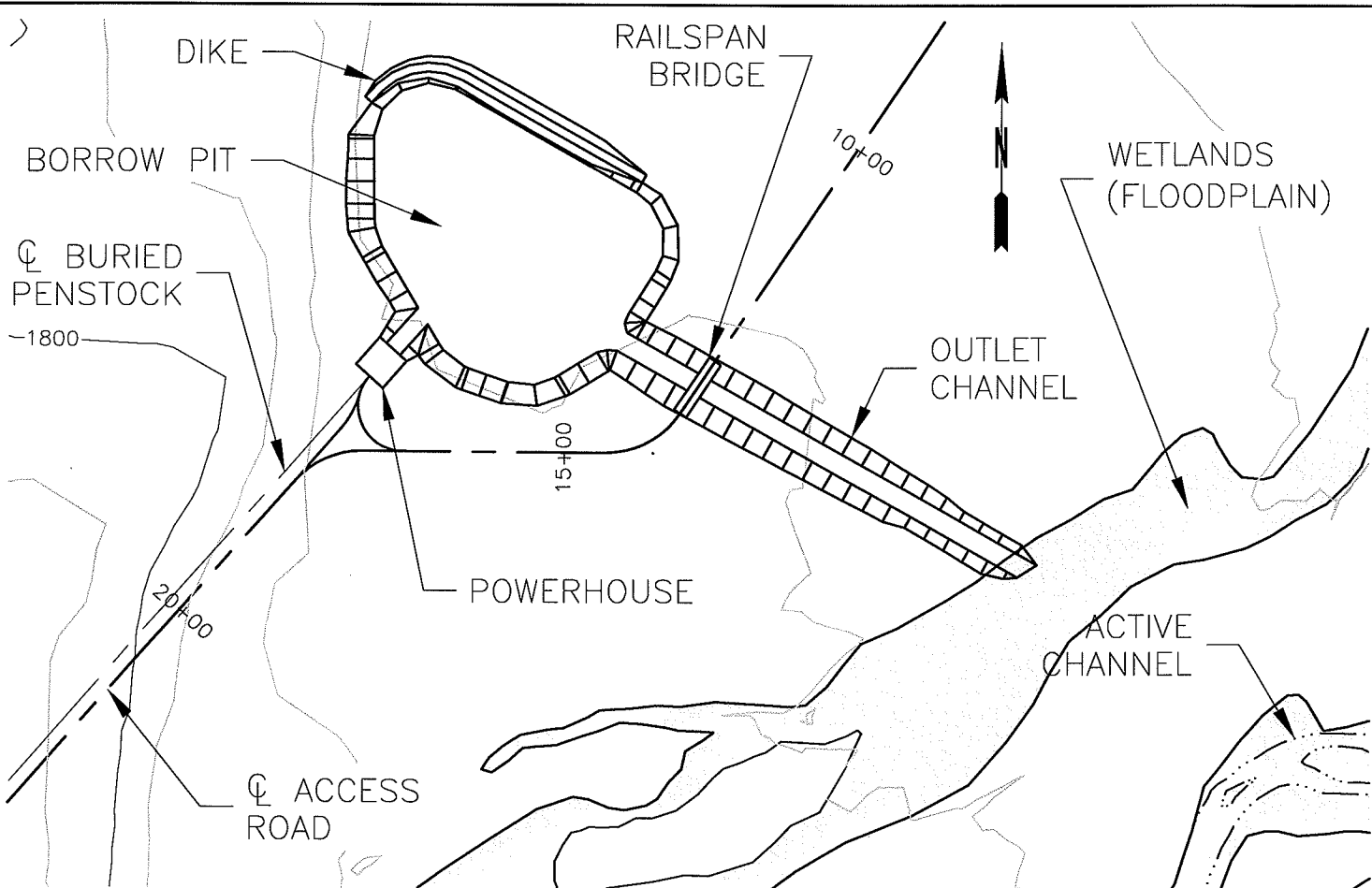

**POWERHOUSE AND TAILRACE PLAN**

SCALE 1"=200'

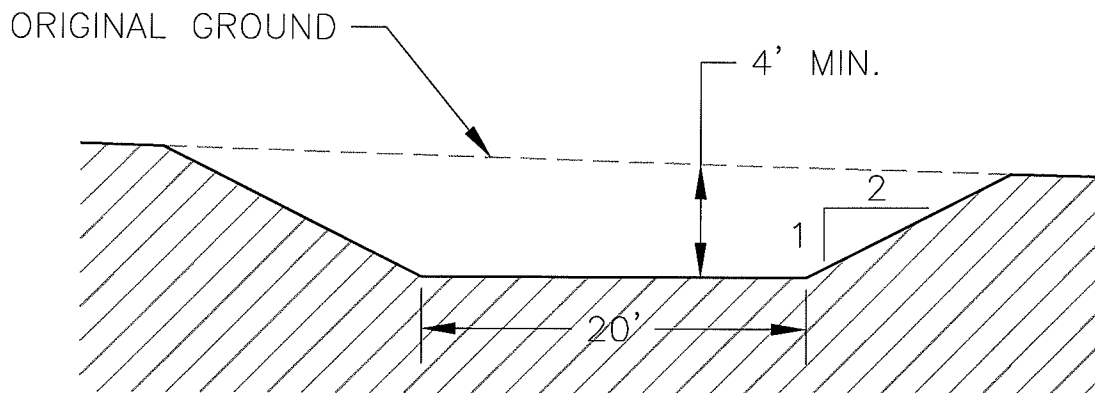

**OUTLET CHANNEL SECTION**

SCALE 1"=10'

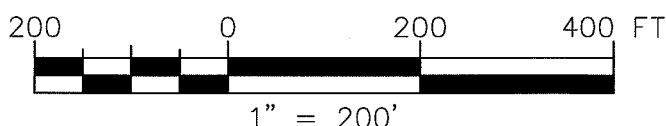
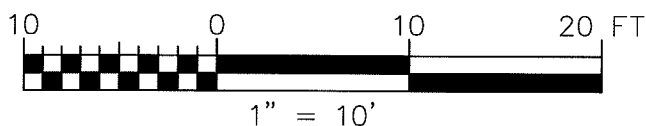

**YERRICK CREEK  
HYDROELECTRIC PROJECT**

**POWERHOUSE AND TAILRACE  
PLAN AND SECTIONS**

DATE: JANUARY, 2010

PROJECT NUMBER:

SHEET NUMBER:

**5**

ISSUE NO.



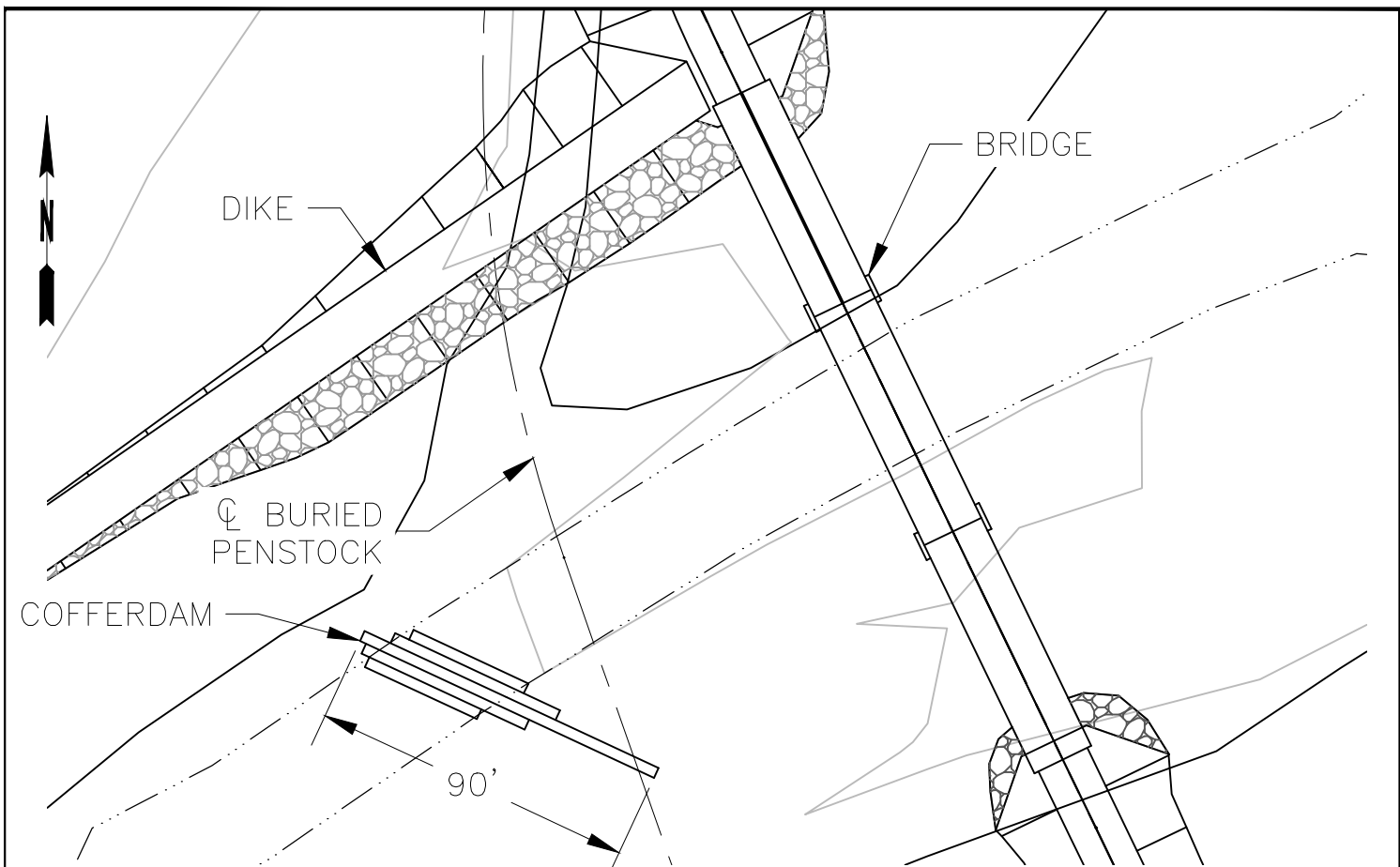

**COFFERDAM PLAN AT BURIED PENSTOCK CROSSING**

SCALE 1"=50'

COBBLE OR SANDBAG TO SECURE MEMBRANE

IMPERMEABLE MEMBRANE

GRAVEL AND SAND-FILLED SUPERSACK, APPROX. 3'x3'x3' EA.

9' MAX.

STREAMBED

**COFFERDAM SECTION**

SCALE 1/4"=1'-0"

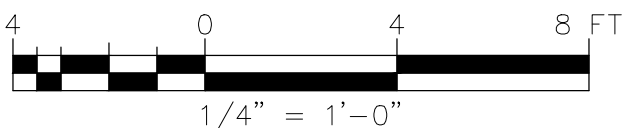
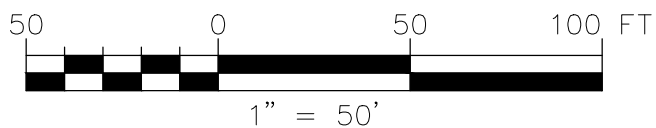

(BLANK PAGE)

**From:** [Glen Martin](#)  
**To:** "[Baij, Harry A Jr POA](#)"  
**Subject:** RE: Update on Yerrick Creek Hydropower Project Permit  
**Date:** Wednesday, April 07, 2010 9:13:00 AM

---

Hank,  
In response to Mr. Moore's comments we offer the following.

Regarding Hydrology, we would not spend our time and money on a site if we didn't think there was sufficient water available to off-set our diesel generation because to build a hydroelectric project is very expensive. We have been gaging out there for a couple years and also had a baseline hydrology and water quality report done for us by a consultant, which I think should have been in the packet I sent you. We also correlated with other similarly sized drainages to develop a curve for Yerrick Creek. To more specifically address this concern we are having an independent hydrologist take our data and create a report. We do have our own hydrologist, but perhaps an independent analysis will carry more weight.

The intake design, etc. will be sufficient to meet the needs of this project without future redesign. We have on our staff civil, mechanical, and electrical engineers. We have built four hydroelectric projects and operate a total of six with many more in the planning and development stages. We have also assisted others in the design and construction of their hydroelectric projects. AP&T also has a reputation in Alaska for developing small hydro successfully.

No company wants to invest in a bad project and we are no different. As for whether there is sufficient seasonal power available, that isn't the issue, we are hoping to get power in all four seasons. During the winter there appears to be reasonably good flow and therefore potentially off-setting part of the diesel we would use that time of year as well. Independent of AP&T, others have considered this to be a good potential site for hydropower because of significant flow below the ice. What also makes this a good site is our transmission infrastructure goes by Yerrick Creek, which will reduce costs for the project (transmission lines are one of the most expensive components of these projects).

I hope this helps. Let me know if you will need anything further.

Regards,

Glen

-----Original Message-----

From: Baij, Harry A Jr POA [<mailto:Harry.A.Baij@usace.army.mil>]  
Sent: Friday, April 02, 2010 9:34 AM  
To: Glen Martin  
Subject: Update on Yerrick Creek Hydropower Project Permit

Hi Glen,

The Alaska Departments of Fish and Game and Natural Resources requested the additional 15 days to provide specific written comments on the proposed work. Therefore, I have extended the review period until COB April 10, 2010. Please also see the comment below from Mr. Moore.

Thanks for your help.

H. Baij  
[harry.a.baij@usace.army.mil](mailto:harry.a.baij@usace.army.mil)  
907-753-2784

-----Original Message-----

From: Moore, Bruce [<mailto:BMoore@dmgz.com>]

Sent: Friday, March 26, 2010 1:14 PM

To: Baij, Harry A Jr POA

Subject: POA-2009-445, Yerrick Creek

Dear Mr. Baij,

I am submitting these comments on behalf of Tanacross, Inc., the landowner for the proposed site of the power generation facility, borrow pits, roadway and tailrace components of this proposed project.

The primary comment we have at this time is to question the amount of hydrologic data for this project and whether or not it is sufficient to support (a) the design of the intake structure and penstock on Yerrick Creek and (b) the long term viability of the proposed facility as a contributing source of inexpensive electric power.

It is not clear to Tanacross, Inc., that Yerrick Creek can support seasonal power generation at a level that warrants the interruption of the stream and construction of permanent generator facility and roadway on Tanacross, Inc., land, and all of the related activities, environmental changes, trespass and long term issues that accompany such a facility. In addition, we would like to see the project, if developed, completed in such a manner that does not require significant modification in the future to remedy design issues that can be addressed now with adequate data.

I would be happy to discuss this further with you at any time. In part, Tanacross, Inc., is relying on your expertise to answer these questions before the project is built. Thank you for your time and consideration.

Bruce Moore

Bruce A. Moore, Esq. |

943 W. 6th Ave., Anchorage, AK 99501 | 907.279.9574

f: 907.276.4231 | [www.dmgz.com](http://www.dmgz.com)

(BLANK PAGE)

# STATE OF ALASKA

SEAN PARNELL, GOVERNOR

## DEPARTMENT OF NATURAL RESOURCES

### DIVISION OF PARKS & OUTDOOR RECREATION OFFICE OF HISTORY AND ARCHAEOLOGY

550 WEST 7<sup>TH</sup> AVENUE, SUITE 1310  
ANCHORAGE, ALASKA 99501-3565

PHONE: (907) 269-8721

FAX: (907) 269-8908

March 24, 2010

File No.: 3130-1R RD  
3330-6 TNX-211  
3330-6 TNX-212

SUBJECT: Yerrick Creek Hydroelectric Project, Determinations of Eligibility for TNX-211 and TNX-212

Mark S. Plank  
USDA, Rural Utilities Service  
1400 Independence Ave, S.W.  
Washington DC  
20250-0700

Dear Mr. Plank,

The Alaska State Historic Preservation Office received your correspondence regarding the above mentioned project on January 13, 2010 and we have reviewed the report titled *2009 Cultural Resources Survey of Alaska Power & Telephone's Yerrick Creek Hydroelectric Project near MP 1334 of the Alaska Highway, Alaska* by Molly Proue and Burr Neely. We concur with your finding that TNX-212 is eligible for listing in the National Register of Historic Places under criterion A for its association with the construction of the Alaska Highway. The period of significance is between 1941 and 1944 and the level of significance is local. We do not concur with your finding that TNX-211 is eligible for listing the National Register of Historic Places under criterion D. Because the route has been redesigned to avoid TNX-212, we concur that this project will have no adverse effect on historic properties.

Please contact Tracie Krauthoefer at 907-26-8722 if you have any questions or if we can be of further assistance.

Sincerely,



Judith E. Bittner  
State Historic Preservation Officer

JEB:tak

(BLANK PAGE)



REPLY TO  
ATTENTION OF:

DEPARTMENT OF THE ARMY  
U.S. ARMY ENGINEER DISTRICT, ALASKA  
REGULATORY DIVISION  
P.O. BOX 6898  
ELMENDORF AFB, ALASKA 99506-0898

## GENERAL PERMIT AGENCY COORDINATION (GPAC)

I am requesting project comments on the proposed project, described below and in e-mail attachments, within ten (10) calendar days from the date of this notification. Today, 16 March 2010 is day zero (0). If additional time is needed to provide substantive, site-specific comments, contact me and I will wait an additional 15 calendar days before making a permit decision. Further information concerning the nationwide permit program can be found at our web site: <http://www.poa.usace.army.mil/reg>.

I am requesting the U.S. Fish and Wildlife Service and the National Marine Fisheries Service to review and comment concerning potential impacts to threatened or endangered species or their critical habitat.

Comments on the proposal need be provided either by e-mail message to [harry.a.baij@usace.army.mil](mailto:harry.a.baij@usace.army.mil), mailed to the letterhead address above, or by calling 907-753-2784.

/s/ H. Baij  
Harry A. Baij, Jr.  
Project Manager

---

**Corps of Engineers Identification:** POA-2009-445, Yerrick Creek  
Mr. Glen Martin  
Alaska Power and Telephone Company  
P.O. Box 3222  
Port Townsend, WA 98368  
360-385-1733  
[glen.m@aptalaska.com](mailto:glen.m@aptalaska.com)

**General Permit:** Nationwide Permit (NWP) 17, Hydropower Projects

**Date of GPAC:** 16 March 2010

**Comment Period Closing Date:** 26 March 2010, close-of-business day

**For Questions, Please Contact:** Harry A. Baij Jr., 907-753-2784

**Project Location:** The project site is located within Sections 1, 2, 11, & 14, T. 18 N., R. 9 E., Copper River Meridian; and Section 36, T. 19 N., R. 9 E., Copper River Meridian; USGS Quadrangle Map Tanacross B-6; approximate Latitude 63.3453° N., Longitude -143.6294° W. The project site is approximately 20 miles west of Tok, AK and near Milepost 133.5 of the Alaska Highway. Yerrick Creek flows north and empties into the Tanana River.



**Project Description:** The proposal to construct a diversion dam hydropower generation facility requires a Corps of Engineers permit because a discharge of dredged and/or fill material would occur in waters of the U.S. as defined by the Clean Water Act Section 404. Yerrick Creek below its ordinary high water mark and any adjacent wetlands are jurisdictional waters of the U.S. under federal code found at 33 CFR Part 328.3. Yerrick Creek is a relatively permanent water flowing into a navigable water of the U.S. at its confluence with the Tanana River.

The proposal qualifies for a NWP because the applicant has received an exemption from licensing from the Federal Energy Regulatory Commission (FERC) under Section 23(b)(1) of the Federal Power Act. A copy of the Order Ruling on Declaration of Intention and Finding Licensing Not Required can be obtained upon request.

The proposal will impact the waters of Yerrick Creek by construction of:

1. A diversion dam placed across the creek channel with a roughened outlet channel, concrete face and rock spillway, left bank abutment dike, right bank water intake and intake drain, all of differing configuration and size;
2. An abutment and pier supported bridge span of approximately 200 ft. long, including a dike and riprap armor for creek bank erosion protection;
3. A buried 48 in. diameter penstock crossing of 10 ft. deep dredged from the creekbed and backfilled with concrete and rock fill;
4. A powerhouse tailrace extending into the creek composed of gravel and rock materials and;
5. Temporary cofferdam to be installed for:
  - a. The diversion structure measuring about 200 ft. long with a varying height of 3 ft. to 9 ft. The diversion structure cofferdam will be in place until the structure is complete and water can freely flow through the sluiceway.
  - b. The buried penstock river crossing measuring a length of about 90 ft. and average height of 9 ft. The cofferdam at the penstock crossing and bridge piling construction will only remain until construction of those features is complete.
6. The grout curtain, in necessary, will be microfine cement pressure-injected into the substrate. There will not be any additional excavation for the grout curtain.
7. The tailrace will discharge into the dry (overflow) creek bed.

Most materials excavated/dredged from the waters of Yerrick Creek will be screened and used for backfill, riprap, and slope protection. Topsoil will be stockpiled at upland storage areas. Any excess materials will be deposited the dryland borrow pits at completion of construction.

The access road, staging areas, most of the buried penstock, power house, material site, and tailrace will be constructed on drylands.

**Mitigation:** The applicant has designed the project to avoid and minimize adverse impacts to the aquatic environment in the location, construction, access, and temporary impacts for staging, stockpiling of materials, material site, and construction techniques. This has been accomplished by reducing the aquatic resource impacts to only those necessary for the dam and penstock crossings which cannot be avoided due to the naturally setting and/or economic considerations. No wetlands will be filled or disturbed. No compensatory mitigation has been proposed by the applicant for the

unavoidable adverse impacts to the creek waters. The applicant has also planned disturbances to minimize the adverse impacts to the upland areas of the proposed work sites.

**Enclosures:** Permit application and plan drawings (sheets 0-6 dated January 2010 & March 2010).

**Additional Information:** An Environmental Assessment of January 18, 2010; Preliminary Jurisdictional Determination of February 2009; Fish Habitat Permit of August 5, 2009; Fisheries Baseline Study of October 2008; and Threatened, Endangered, and Sensitive Plant Report of February 2009 are all available for review upon request.

(BLANK PAGE)

# STATE OF ALASKA

## DEPARTMENT OF FISH AND GAME

### DIVISION OF HABITAT

**SEAN PARNELL, GOVERNOR**

1300 COLLEGE ROAD  
FAIRBANKS, AK 99701-1551  
PHONE: (907) 459-7289  
FAX: (907) 459-7303

March 5, 2010

Mr. Glen Martin, Project Manager  
Alaska Power and Telephone Company  
P.O. Box 3222  
Port Townsend, WA 98368-3222

Dear Mr. Martin:

Re: Yerrick Creek Hydroelectric Project, Fish Habitat Permit FH09-III-0182

The Alaska Department of Fish and Game (ADF&G) Division of Habitat issued Fish Habitat (Title 16) Permit FH09-III-0182 on August 5, 2009 to Alaska Power and Telephone Company (AP&T) for construction of the Yerrick Creek Hydroelectric Project west of Tok.

We would appreciate an update on the overall project status. Is AP&T anticipating ground-disturbing or other on-site work this year? Have there been any changes in project scope or specification of which ADF&G needs to be aware?

Permit stipulations in FH09-III-0182 require ADF&G review and approval of AP&T's civil plans for the impoundment dam and excess flow bypass, and for fish exclusion at the penstock intake, before construction begins. What is the status of those plans, and when should we expect them for review?

We look forward to working with AP&T as this project progresses. If you have questions contact me at 907-459-7281 or mac.mclean@alaska.gov.

Sincerely,



Robert F. "Mac" McLean  
Regional Supervisor

ecc: Tim Pilon, ADEC Water, Fairbanks  
Bonnie Borba, ADF&G CF, Fairbanks  
Fronty Parker, ADF&G SF, Fairbanks  
Joe Klein, ADF&G SF, Anchorage

Jim Ferguson, ADF&G SF, Anchorage  
Jim Simon, ADF&G SUBS, Fairbanks  
Jeff Gross, ADF&G WC, Tok  
Chris Milles, ADNR Land, Fairbanks

RFM/jdd

(BLANK PAGE)

# ALASKA POWER & TELEPHONE COMPANY

P.O. BOX 3222 • 193 OTTO STREET  
PORT TOWNSEND, WA 98368  
(360) 385-1733 • (800) 982-0136  
FAX (360) 385-5177

February 22, 2010

Bruce Moore  
DeLiso Moran Geraghty & Zobel, Inc.  
943 West Sixth Avenue  
Anchorage, AK 99501-2033

RE: Response to January 28, 2010 Letter  
Yerrick Creek Hydroelectric Project

Dear Mr. Moore:

In response to your January 28, 2010, letter to Ted Wellman, Esq., we would like to provide the following information to address your questions and concerns.

First, we apologize for not forwarding reports to Tanacross, Inc. as they became available to keep Tanacross apprised of the investigations into this project. This was an oversight, and we will strive to forward any future reports as soon as we receive them. We have included all the existing reports on a CD included with this letter.

Going through the January 28 letter in the order provided, we offer the following:

## A. ENVIRONMENTAL ASSESSMENT REPORT

1. Summary: We will include in the environmental assessment a short description of our effort to explore the potential for biofuel generation. In short, we were looking into the possibility of a 2 MW sized biomass project using wood from the area, but funding was not made available to AP&T by the state in their recent grant funding for Renewable Energy Fund Round III. This project will not be pursued in the near term unless grant funding becomes available.
2. Project Description: AP&T has had a gage on Yerrick Creek near the diversion site since June 2007, however, no formal reports have been prepared regarding the stream flow data. In addition, flooding in the summer of 2008 destroyed the gage installation, which was relocated in the fall. Good data at the new site did not begin recording until the spring of 2009, therefore the July 2007-June 2008 data is the only full year of data that is currently available. Based on that one year of flow data and correlation with other gaged streams, we estimate that during a typical year the project diversion of up to 60 cfs will utilize all of the flow in the stream from about August 15 to July 1. From July 1 to August 15 there will often

be enough flow from snowmelt in the basin so that excess water will pass over the spillway and flow in the creek channel below the diversion structure. The duration of this spill flow will be intermittent, and of course will vary with the amount of snow accumulated in the basin; during low runoff years there may be only a very short period of spill, but during high runoff years the spill period may start in June and extend through August.

Because of the porosity of the streambed material at the diversion site, it is likely there will be some seepage under and around the diversion structure that could provide flow in the creek. AP&T may grout the streambed material to reduce the seepage; preliminary estimates are that seepage could amount to as much as 6 cfs without grouting and 1 cfs with complete grouting. Springs near the proposed bridge will also continue to discharge into Yerrick Creek.

The enclosed CD contains two hydrology documents. One is a report by Paul Berkshire dated July 2007, which estimates Yerrick Creek flows by correlation with data from Berry Creek near Dot Lake. The second is a graph of the July 2007-June 2008 flow data collected by AP&T.

3. Access Road: By letters dated January 28, 2009 and February 18, 2009, AP&T provided Tanacross with a preliminary right of way map that clearly indicates an access road from the Alaska Highway to the diversion structure. However, there appears to be some confusion. The subject of those letters was to obtain permission from Tanacross to cross Tanacross lands for field work during 2009; there was reference to a permanent access road construction possibly in the fall of 2009 if the necessary permits could be obtained (they weren't). Any discussion in those letters regarding trail easement and subsequent reversal following trail construction was solely related to trail construction that might be necessary for the 2009 field work. As indicated in Tanacross's authorization letter dated June 10, 2009, Tanacross fully understood that the actual construction of the project, including the access road, was still to be authorized.

The project will be a major construction effort, and cannot be accomplished without an access road. Furthermore, operation and maintenance of the project will require visits to the diversion structure at least once per week, which necessitates maintaining the access road during the operating life of the project. We have no other purpose for the road, and expect to have locked gates to control unauthorized access. We will work closely with Tanacross to develop an acceptable trespass mitigation plan.

There also appears to be some confusion regarding the right-of-way width and the width of the actual road. The 100' right-of-way width has been proposed to provide us with a corridor in which to site the road and penstock. The actual area utilized will usually be much less. The road will have a traveled surface with of 15 feet, but there will be additional width for embankment shoulders and/or sidehill cuts with ditches. The penstock will be buried adjacent to the road, and

the ditch excavation will require additional width. We estimate that for most of the road, we will need to clear only about 50 feet of width within the 100' right-of-way. In steep sidehill areas, the cleared width necessary for the road embankment and cuts may approach the 100' width. If this width is an issue with Tanacross, we are willing to survey the project after construction and limit the right-of-way to that actually utilized.

Finally, we would like to point out that the access road and penstock alignment has been and may continue to be a moving target. Our previous maps provided to Tanacross showed the alignment located out of the creek valley as much as possible to minimize flood risks; however, as a result of our 2009 field work, we now believe the best route for the road and penstock is on the valley margins in the upper portion and out of the valley in the lower portion. Although the alignment shown in our EA is considered firm, we acknowledge that there could be minor adjustments during final design and construction.

4. Environmental Assessment: We understand there can be confusion with the permitting process for a hydroelectric project. Because this project will be partially on state land we have to apply for a DNR land use permit, which we have done (October 18, 2007). Because we will be using state water we also have to apply for a DNR water use permit, which we have also done (May 31, 2007). The land use permit must be issued before we can begin construction. However, the water use permit will not be issued until operations begin, but our application did give us priority on this site for the use of water in case anyone else applies.
5. Purpose and Need for Action: The cost to provide power to our customers who are dependant on diesel generation is constantly changing. As of October 2009 AP&T's customers in Tetlin, Tok, Tanacross and Dot Lake were paying **\$0.47** per kWh (excluding PCE). Once the Project interties with the Tok grid, the cost per kWh could be reduced by approximately 20% to about \$0.37 per kWh (excluding PCE). Lower energy costs would help stimulate both residential and commercial development.

In regards to the changing size of the project from 3 MW down to 1.5 MW, this number may still vary until we have completed the final design, however, this number has changed as we have gained a better understanding of this drainage and the amount of water available.

6. Alternatives: We will include biofuel in the discussion in the EA of other energy technologies considered. However, as mentioned above, at this time this technology is unlikely to be developed very soon because funding is unavailable. In order to get the communities on the Tok grid off of diesel generation it will require a combination of renewable energy projects to make this happen. Biofuel is also less reliable than hydroelectric power in that wood will have to be purchased for the biofuel project and will therefore be dependant on reliable and available resources.



7. Affected Environment: Our fish biologist, Steve Grabacki (Anchorage), described the creek as, "*For most of its length, Yerrick Creek is a cascading stream with fast flow and boulder substrate. The stream generally comprises 1-3 channels, within a wide dynamic (scoured) perimeter.*" The description we used in the EA was from the archaeological report describing the creek, but we will switch to the fish biologist's description since that may more accurately describe the creek. We have included Mr. Grabacki's report in the attachments.

In regards to Dolly Varden, Arctic Grayling became the focus of ADF&G after they determined this project would not have a significant impact on Dolly Varden. You are correct though, we should mention Dolly Varden as well and will update the EA to reflect this.

8. Cultural Resources: The statement, "*No historical use was identified in the drainage*" was a result of the teleconference held with Tribal representatives, RUS, and AP&T on November 13, 2008. There was no mention of cultural use that anyone was concerned about. That statement was to reflect the results of the teleconference; perhaps that can be stated more clearly. A trail was mentioned during the teleconference, but maps show the Eagle Trail from Tanacross being east of the Yerrick Creek drainage, therefore, based on the teleconference there was no historical use identified (the map is on the CD). In that paragraph we then go on to state what was found in subsequent archaeological surveys, providing this information in a chronological manner. Dall sheep hunting is mentioned in the wildlife section and since this project will not impact historical use of the mountain ridges by preventing access, this was not mentioned.
9. Wildlife: In regards to what the project features are going to be, regarding impacts to wildlife, there will be areas that are cleared of vegetation. The powerhouse, staging area, and lower borrow area are near the Alaska Highway and a total of 5.2 acres will be cleared for this group of features. This area's forest is not dense and impacts to wildlife will be minimal because there is plenty of similar habitat in the area. Game that use this area are black and brown bear, moose, and possibly migrating caribou. Dall sheep most likely stay at higher elevations. The 21.9 acres of Tanacross, Inc. land for the access road and penstock are often used by wildlife as a route to get around, although the forest in this area is not that dense for the most part, so that the road may not become a travel corridor. Although this project feature removes habitat, the loss is not significant because the amount of land is small in comparison with the surrounding undeveloped area. The tailrace will clear an area of about 0.6 acres and will drain from the borrow pit next to the powerhouse after construction is complete.

In regards to increased hunting pressure, sport and subsistence hunting go hand-in-hand in this area, although most is by Alaskan hunters and is therefore most likely for subsistence. However, sheep hunting is controlled by a drawing for a permit, only so many are allowed, so increased access should have little impact to this species because only so many can be legally harvested. Of the participating

hunters, 94% were Alaska residents in regulatory years (RY) 2001-2003, of which 92% of the harvested rams were by Alaskans.<sup>1</sup>

For Macomb caribou, only one was harvested in Unit 12 in RY2001-2002 and RY2002-2003. Highway vehicle followed by horse are the dominant methods to hunt Macomb caribou in recent years.<sup>2</sup>

Brown bears are distributed throughout Unit 12. Unit 12 brown bear hunting regulations were liberalized in 1981 to reduce the bear population and elevate moose calf survival. *"In 1994, the Unit 12 brown bear management goal to reduce the brown bear population to increase moose calf survival was eliminated and the management goal was revised to provide for maximum opportunity to hunt brown bears in Unit 12. The management goal has remained the same since 1994."*<sup>3</sup> During RY 04 & 05, non-residents of Alaska accounted for 65% and 75% of the harvest respectively. For black bear, Alaska residents accounted for 89-93% of those harvested during RY98-RY00. Yerrick Creek does not contain a reliable source of fish in the project area (diversion to the powerhouse) to attract bears to feed. Other streams along the Tanana River have better runs of grayling and Dolly Varden.

Regarding moose, *"Predation by wolves and grizzly bears has likely been the greatest source of mortality for moose in Unit 12 and has likely been the major factor keeping the population at a low density since the mid 1970s. In contrast to most other areas that contain sympatric moose, wolf, and grizzly bear populations, wolves, rather than bears, appeared to be the primary predator on moose calves on the Northway-Tetlin Flats, based on research conducted during the late 1980s (ADF&G, unpublished data; U.S. Fish and Wildlife Service, unpublished data). Wolf predation also appeared to be the greatest source of adult mortality. However, in some mountainous areas of Unit 12, fall composition data indicate that predation on moose neonates was high, suggesting grizzly bear predation."*<sup>4</sup> Hunters using 3 or 4 wheelers accounted for the highest percentage of the harvest with highway vehicles next. Predation by wolves and bears shows that other natural processes have a far greater impact on moose than humans.

---

<sup>1</sup> Parker McNeill D.I. 2005. Portions of Units 12, 13C, and 20D Dall sheep management report. Pages 68-79 in C. Brown, editor. Dall sheep management report of survey and inventory activities 1 July 2001-30 June 2004. Alaska Department of Fish and Game. Project 6.0. Juneau, Alaska.

<sup>2</sup> DuBois, S. D. 2007. Units 12 and 20D caribou. Pages 65-82 in P. Harper, editor. Caribou management report of survey and inventory activities 1 July 2004-30 June 2006. Alaska Department of Fish and Game. Project 3.0. Juneau, Alaska, USA.

<sup>3</sup> Gross, J. A. 2007. Unit 12 brown bear. Pages 132-142 in P. Harper, editor. Brown bear management report of survey and inventory activities 1 July 2004-30 June 2006. Alaska Department of Fish and Game. Project 4.0. Juneau, Alaska, USA.

<sup>4</sup> Hollis, A. L. 2006. Unit 12 moose. Pages 126-143 in P. Harper, editor. Moose management report of survey and inventory activities 1 July 2003-30 June 2005. Alaska Department of Fish and Game. Project 1.0. Juneau, Alaska, USA.

Management of these species with harvest limits is what controls the human take of these species. Putting a road into the Yerrick Creek drainage to reach the diversion site may provide easier access for hunters, but all these species require permits to harvest. The harvest total for the management unit is based on what the populations can tolerate. This short road into Yerrick Creek will not change management of these species, even if it makes it easier to get into this area. AP&T welcomes dialogue with Tanacross, Inc. to determine the best way to prevent people from using the access road to hunt on Tanacross, Inc. property.

10. Botanical Survey: We have included on the enclosed CD the TES botanical survey conducted by HDR, Inc. out of Anchorage.
11. Flood Plains / Wetlands: We have included on the enclosed CD the Wetlands Jurisdictional survey conducted by HDR, Inc. out of Anchorage.
12. Environmental Justice / Social Economics: As mentioned above in 1. Summary, we will include in the environmental assessment a short description of our effort to explore the potential for biofuel generation. In short, we were looking into the possibility of a 2 MW sized biomass project using wood from the area, but funding was not made available to AP&T by the state in their recent grant funding for Renewable Energy Fund Round III. This project will not be pursued unless grant funding becomes available. This type of energy may not be as reliable as hydropower as we would be relying on a person or persons providing the wood and the continued availability of that wood.

In regards to the different prices for electricity, i.e. \$0.47 or \$0.37 kWh, the cost fluctuates based on the cost of diesel generation whose cost is constantly changing. However, as stated above in 5. Purpose and Need for Action, the current cost is \$0.47 kWh and our current estimated is that the cost would drop to approximately \$0.37 kWh once the project is in operation. The price will continue to fluctuate in this area until we can get them completely off of diesel generation.

You mention the negative effects of trespass, loss of land, and affects to wildlife and subsistence and trapping, etc. were not mentioned. To address this, we would be willing to enter into a contract with Tanacross, Inc. to provide some financial compensation for the use of their land, which would mitigate the effects of trespass and loss of land. Affects to wildlife are described previously in this letter, but impacts will be minor because of the small footprint this project will have on the area. Subsistence and recreation hunters will have easier foot access to part of this area and wildlife is heavily controlled and monitored by state and federal agencies that permit the amount of take allowed in the area. Hunting is not allowed without a permit and only so many are allowed to be harvested. These factors significantly impact the concern of allowing easier access to the area for harvesting wildlife.

13. Environmental Consequences: From AP&T's experience with construction sites, wildlife move through when activity has ended for the day, or activity has moved on to another area. Another example is with housing developments, wildlife will continue to try and use their historical corridors of movement during and after homes have been built and occupied. Corridors created by construction, such as roads, are frequently used by wildlife as a corridor to move from point to point and also to brows on the vegetation along the road. There are no specific migration routes identified by the resource agencies for this site, however, they know that they can and do cross the drainage, not necessarily in the project portion, but it is possible. The project site is not a major migratory corridor. We will more strongly state this in the EA.

If Tanacross, Inc. is concerned about garbage being left at the gate to the site, AP&T would be willing to keep it clean at our expense as part of the agreement we hope to finalize with Tanacross, Inc. in the near future.

14. Water Quality and Quantity: The full statement is as follows, "*With the erosion and sedimentation control methods AP&T proposes to employ (i.e. silt fencing, jute netting, seed mix using annual non-invasive species, using as narrow a corridor as possible, and use of riprap to stabilize slopes along with revegetation as needed) during and after construction of the project, water quality should be only minimally impacted and therefore the project should have no significant impact.*" We believe this statement clearly states why there should be only minimal impacts to water quality.

15. Flood Plains / Wetlands: As described above under 2. Project Description, "*AP&T has had a gage on Yerrick Creek near the diversion site since June 2007, however, no formal reports have been prepared regarding the stream flow data. Based on the flow data collected to date and correlation with other gaged streams, we estimate that during a typical year the project diversion of up to 60 cfs will utilize all of the flow in the stream from about August 15 to July 1. From July 1 to August 15 there will often be enough flow from snowmelt in the basin so that excess water will pass over the spillway and flow in the creek channel below the diversion structure. The duration of this spill flow will be intermittent, and of course will vary with the amount of snow accumulated in the basin; during low runoff years there may be only a very short period of spill, but during high runoff years the spill period may start in June and extend through August.*" We will add this to the EA. We will also provide a description of the fish passage device ADF&G has asked us to include.

Confining the footprint of the project to what has been described is not inconsistent with developing a project with as narrow a footprint as possible. The point of the statement is that AP&T will confine its activity to what is necessary as far as clearing and not unduly create clearing where it isn't needed. This means keeping as much vegetation and topsoil in place as possible. The 100 foot right-of-way is to allow on-site modifications to the route of the road/penstock if

some barrier, such as a subsurface bedrock ridge, is encountered during construction. The intent isn't to clear a 100-foot-wide path through the forest, but to allow adjustments as needed while construction is underway and to prevent delays in construction by seeking additional approval when these barriers are encountered.

## B. 2009 CULTURAL RESOURCE SURVEY

We have included the complete report on the enclosed CD and will forward any future reports as they occur. Regarding your comments on the Cultural Resource Report from Northern Land Use Research, Inc. (NLUR), it stands on its own merits. We do not question their approach to the analysis of this area.

AP&T chose to avoid the artifacts found in the area of the well used pullout on the south side of the highway because it reduces costs, simplifies the issues, and allows project design to move forward without conjecture that other things may be found that could slow construction up. You request copies of previous archaeological studies performed in the area, but we have not been able to get them. We suggest you contact NLUR.

We welcome any further questions you may have.

Sincerely,

A handwritten signature in black ink that reads "Glen D. Martin". The signature is written in a cursive style with a long, sweeping underline.

Glen D. Martin  
Project Manager  
(360) 385-1733 x122  
[glen.m@aptalaska.com](mailto:glen.m@aptalaska.com)

Enc. (as stated)

(BLANK PAGE)

Law Offices

**VIA U.S. MAIL & EMAIL**

January 28, 2010

Ted Wellman, Esq.  
Davis Wright Tremaine, LLP  
701 W. 8th Avenue, Suite 800  
Anchorage, Alaska 99501

**Re: Yerrick Creek**

Dear Mr. Wellman:

This letter follows our conversation and exchange of information prompted by DNR's request for input from Tanacross Incorporated ("Tanacross") on the Yerrick Creek Hydroelectric Project ("Project"). You provided me with a draft Environmental Assessment prepared by AP&T and a 2009 Cultural Research Survey of the Project prepared by Northern Land Use Research, Inc. ("NLUR"). Subsequently, and with your consent, we have obtained a copy of the 2008 Cultural Research Survey performed by NLUR. What follows is an outline of comments and questions regarding those three documents for AP&T's consideration and future discussion with Tanacross.

First, however, I would like to remind AP&T that it has affirmatively agreed to provide Tanacross with copies of "all raw and analyzed data, maps, reports and similar materials regarding the Yerrick Creek Project." The three reports addressed in this letter were not provided until requested, and they are the only reports provided to Tanacross by AP&T regarding this Project. If AP&T expects Tanacross to evaluate this Project as an appropriate long-term use of its land, then AP&T must follow through on its obligation to provide the information for that evaluation.

You may appreciate that the problem with the non-production of information by AP&T is partly economic. In order to responsibly manage its lands, Tanacross has been required to go out and obtain its own information on this project. This requires an expenditure of time and money, and increased professional fees, that is only being incurred because AP&T wants to build a hydroelectric plant on Tanacross land. I suggest we arrange a meeting of our clients as soon as convenient to discuss this and other issues.

As to the reports, Tanacross recognizes that the Environmental Assessment Report was submitted as a Draft and agrees that it needs much more work. Our comments

Joseph M. Moran  
Michael C. Geraghty  
Patricia L. Zobel  
Bruce A. Moore  
Danielle M. Ryman  
Adolf V. Zeman  
Nora G. Barlow  
Stephanie M. Shanklin

Stephen S. DeLisio, *Of Counsel*  
John R. Beard, *Of Counsel*

below are provided to help AP&T identify inconsistencies and other areas that need improvement. We appreciate the opportunity to comment at this early stage.

#### **A. ENVIRONMENTAL ASSESSMENT REPORT**

1. Summary: In the second paragraph, this Project is described as benefitting air quality by reducing air pollutants from diesel generation of electricity. There is no mention in this section or in this report of biofuel generation of electricity. Does that mean AP&T is not pursuing biofuel as a source of power for generating electricity in the Upper Tanana Valley?

2. Project Description: AP&T identifies a design parameter of approximately 60 cu.ft. per second for the maximum flow that can be handled by the Project. It then identifies the fact that this will use all of the water of Yerrick Creek for part of the year. Tanacross would request AP&T to provide hydrology reports that identify which parts of the year the Project will use all of the water from the creek.

3. Access Road: In the second paragraph of the Project description, AP&T identifies that there will be approximately 3 miles of access road with a surface of approximately 15 feet in width from the highway to the diversion site. This is the first time Tanacross has been made aware of this permanent road.

In the general plan and preliminary right-of-way maps provided to the state by AP&T and then, in turn, provided to Tanacross for the teleconference, AP&T has identified a penstock and access road right-of-way of 100 feet. Previously, as explained to Tanacross by AP&T, the penstock was going to be placed in or near the dry creek bed, the trail and the creek bed were going to be used as a means of access to the containment facility, and development of the trail easement for use during construction was to be reversed following construction. AP&T has not presented a case on why the easement should be 100 feet wide for a 15 foot wide road and buried penstock.

4. Environmental Assessment: The third paragraph of the Project description in the environmental assessment draft states that DNR water rights permits are received after Project start up. After talking to DNR, we believe that AP&T will need to first obtain a permit to develop a water source prior to doing any start up.

5. Purpose and Need for Action: In this section, AP&T identifies a likely seven-cent (7¢) per kilowatt-hour reduction in electric rates resulting from this Project. However, in AP&T's 2008 project description provided to RUS, the reduction was



identified as being approximately 20 per cent (20%). In addition, the generator is described variously as a 2.0-megawatt, a 1.5-megawatt, a 2.3-megawatt, and a 3.0-megawatt generator.

6. Alternatives: In the section, AP&T provides a description of other energy generation technologies that are considered; however, nowhere in this discussion is there a mention of biofuel generation. Tanacross understands from discussions with others that, in fact, AP&T is considering developing biofuel generation. How does that alternative measure up against hydro?

7. Affected Environment: In this section, Yerrick Creek is described as a typical meandering Interior creek. However, Tanacross believes this an "alluvial fan Interior creek" and therefore not a "typical meandering" creek. In this section, AP&T also states that fish surveys were conducted by a qualified fish biologist. The name of that individual is not provided. (Tanacross got the 7-24-2009 report through DNR.)

The discussion of the results of the qualified fish biologist focuses entirely on grayling use of Yerrick Creek and does not describe the habitat and use of Yerrick Creek by Dolly Varden. In other sections, the report concludes that there will be minor impact on Dolly Varden; however, there is no discussion of what that impact will be on the Dolly Varden use of Yerrick Creek.

8. Cultural Resources. The assessment states "No historical use was identified in the drainage." To the contrary, the cultural resource survey identified construction of the Haines Fairbanks pipeline, the Alaska Highway, hunting camps, trap lines, and a homestead area. These are historical uses of the drainage. In addition, Henry T. Allen identified an important trail in the area in 1885 and Kenneth Thomas identifies the area as being used for hunting sheep. Clearly, this section needs to be revised.

9. Wildlife: In this section, there is discussion about the powerhouse site, staging area for materials, the access road and penstock route, and diversion site, but there is no actual description of what these sites or any material source locations within the land are going to be.

The comment is made that the main concern would be whether this Project will provide hunters and trappers easier vehicular access into the basin. This, along with avoiding any impact on the natural gas pipeline, is one of the major concerns of Tanacross. AP&T includes no discussion of how it intends to mitigate

this impact. To the contrary, the cultural resource studies identify AP&T personnel and one individual specifically that have been trespassing on Tanacross land for many years.

If increased hunting pressure is expected to result from improved access via the road and parking lot, it would seem that an evaluation of the effects of that on both sport and subsistence hunting should be included in the Environmental Assessment. What species are expected to be most affected? How?

10. Botanical Survey: In this section, AP&T makes reference to a qualified botanist but does not identify who that is and does not provide any information regarding the report of that botanist. In that same section, AP&T comment that most plant species in the area are considered common. However, it does not identify what other species there are in the area.

11. Flood Plains / Wetlands: In this section, AP&T references a wetlands determination survey but does not identify who conducted the survey and has not provided a copy of the survey to Tanacross.

12. Environmental Justice / Social Economics: In this section, AP&T does not discuss the possible alternative of biomass generation. AP&T references a cost per kilowatt-hour of 0.47, which is significantly higher than the rate identified earlier in this report as well as in its previous project description to USDA Rural Utilities Service of .37 per kilowatt-hour.

This section also discusses the Tok School but, again, makes no mention of biomass generation.

The Native villages of Tanacross and Tetlin are cited as possibly benefitting from this project, but there is no mention of negative effects from trespass, loss of land, affects of wildlife and subsistence and trapping, and the like.

13. Environmental Consequences: In this section under Alternative (2), AP&T describes what "usually happens to wildlife during this type of construction activity." It does not provide a citation to its understanding of what usually happens. It also comments that impact to a wildlife corridor will result in continued use but a change in the time of day that wildlife cross the area of activity. AP&T does not identify whether there are any migration routes impacted by this activity.

AP&T also discusses the impact of ATV access to the Project through Project roads. AP&T concludes that this is not expected to be a significant impact because this is a remote part of Alaska. The experience of Tanacross with access roads in remote parts of Alaska is that they often become dumping sites for trash, household debris due in large part because it is a remote area. In those situations, the landowner ends up with a tremendous burden. This is not discussed at all.

14. Water Quality and Quantity: In this section, AP&T concludes that water quality "should be" only minimally impacted but does not explain why it believes that is the case.

15. Flood Plains / Wetlands: In this section, AP&T does not provide any basic hydrology data, describe the annual flow cycle of Yerrick Creek, or explain whether and how Dolly Varden will pass the diversion structure. AP&T also explains that it intends to confine its construction activity to a narrow footprint but that seems inconsistent with material sites, borrow sites and the need for a 100-foot right-of-way.

At this point, the Environmental Assessment Report becomes largely incomplete and contains several sections that need to be addressed.

## **B. 2009 CULTURAL RESOURCE SURVEY**

1. Confidentiality Notice: This addresses the confidentiality notice. I believe this notice should identify the landowner as one of the parties intended for release of the document.

2. Section 1.2, Yerrick Creek: This describes Yerrick Creek as "a typical meandering Interior creek with some islands of vegetation present in the channel." As mentioned above, this is a alluvial fan creek that doesn't meander in the typical sense. It has a braided channel that indicates a significant seasonal movement of water and materials.

3. Section 1.3, Project Description: The 2008 Report indicates that local AP&T personnel treat the Haines Fairbanks Pipeline boundary as the dividing line between Tanacross and state land. This, of course, is approximately one mile in error. It also raises questions as to why AP&T personnel would even be in this area and, if they were, why were they not using maps.

4. Section 2.1, Research Design: This discusses references about the pre-history and history of the Middle Tanana Basin. In local usage, this area of Yerrick Creek, Tanacross and the villages involved in this Project are considered part of the Upper Tanana Basin.

5. Section 2.2, Field Survey Methods: Local resident and AP&T employee "Mike" is identified as a person who has seasonally hunted and trapped along Yerrick Creek for approximately 10 years. From the landowners' perspective, it would also be appropriate to say this has been an on-going trespass unless Mike is a Tanacross shareholder or descendant. It may be, however, that local resident and AP&T employee Mike may be a valuable resource for AP&T in terms of designing a system to prevent trespassers in the area. He has apparently been traversing the area on foot and with the use of an ATV, and has several traps and sites established on or near Tanacross land.

6. Section 3.1, Powerhouse Site The 2009 Survey indicates the powerhouse site sits directly in the creek bed. Later, it appears that AP&T seems to have moved its whole power house, material site, and staging area west to avoid the TNX-00212 site, the camp for Western Engineering while building the Yerrick Creek Bridge. Won't increased access due to the road and the parking lot also make it more likely that "bottle-hunters" will find and destroy the cultural resources found in TNX-00211 and -00212?

In addition, there is -a land use argument to be made that a site once disturbed should be reused rather than developing a 5 acre site somewhere else. Has AP&T considered whether it is more appropriate to use the historic site? Perhaps it is more prudent to fully evaluate and preserve the cultural resources found at these sites before construction begins rather than to leave them *in situ* and vulnerable to disturbance.

7. Section 3.3, Previous Archeological Research: The NLUR identifies a previous project that it performed on Tanacross property. It would be appropriate for NLUR to identify this project and provide materials generated by it to Tanacross. The same section also mentions ATV trails existing in the Haines Fairbanks Pipeline corridor that is entirely on Tanacross land. These ATV trails will need to be addressed in a trespass mitigation plan.

8. Section 4.3, Proposed Penstock Location: The report states that AP&T is proposing to place a penstock in dry portions of the Creek. This is consistent with the understanding of Tanacross prior to reviewing the Environmental Assessment

Report and maps provided by the state. It now appears that the penstock is not going to be in the creek but situated within in a 100-foot right-of-way that has yet to be discussed with Tanacross.

9. Section 4.4, Access Road: This describes a single-lane permanent access road from the power plant to the impoundment area. It also describes recent uses that demonstrated an active and recent past use of the Yerrick Creek margins. Thus, one could conclude that a permanent road would likely increase the types of uses identified in this Section.

10. Section 5.0, Summary and Recommendations: This identifies a Native tribal contact for Tanacross Native Corporation, Inc., that is not a member of Tanacross and not related to Tanacross, Inc. This information has been presented to NLUR.

11. Appendix A, Description of Pedestrian Survey: This identifies a bear baiting station that has been established with an associated ATV trail near the river close to the Haines Fairbanks Pipeline corridor. This station is on Tanacross land.

Further, in the same section, Mike's ATV trails throughout the area are described and AP&T is using these trails to take water flow measurements.

### **C. 2009 CULTURAL RESOURCE SURVEY**

1. Section 1.1, Project Background: In the second paragraph of this section, it identifies the Project as being at Milepost 1334 whereas the draft Environmental Assessment Report identifies it at Milepost 1339.

This report appears to contain many of the same comments included in the 2008 report that won't be repeated here.

2. Section 3.2.6, Route C; Section 3.2.7, Route D: AP&T employee the bear baiting station and pole trap appear to be identified.

3. Section 4.2, Final Alignment: This identifies three ancillary facilities: a powerhouse, a material source and impoundment area. None of these has been identified in any specific manner to Tanacross.

Ted Wellman, Esq.  
January 28, 2010  
Page 8 of 8

#### D. AP&T MAPS

Prior to the teleconference with the state, DNR forwarded to Tanacross three half-sized drawing maps prepared by AP&T showing a general plan, a preliminary right-of-way and identifying an existing trail. These maps contain information that Tanacross is seeing for the first time, such as the concept of a 100-foot wide right-of-way for the penstock and access road; a five-acre area for a powerhouse staging area and barrow area; and an explanation that the total area encompassed by the Project is 56 acres.

This latter description is inconsistent with the Environmental Assessment Report that identifies 40 acres of state land and 35 acres of private land will be needed as part of an easement.

Those are the comments we have at this time. Please give me a call to discuss this further. Thank you for your attention.

Very truly yours,

DeLISIO MORAN GERAGHTY & ZOBEL, P.C.

By: \_\_\_\_\_

  
Bruce A. Moore

(BLANK PAGE)

**From:** [Glen Martin](#)  
**To:** ["McGee, Lauren - Washington, DC"](#)  
**Subject:** RE: Yerrick Creek Cultural Resource Report OHA Coversheet  
**Date:** Thursday, January 14, 2010 11:20:00 AM  
**Attachments:** [Doyon\\_Map\\_Tanacross.pdf](#)

---

Lauren,

Thank you. I recently downloaded a map that shows the trail I think Tanacross, Inc. was referring to, the Eagle Trail? Anyway, this map shows an historic trail east of our project, but not through our project. This makes more sense as it avoids the steep, high terrain.

Glen

---

**From:** McGee, Lauren - Washington, DC [mailto:Lauren.McGee@wdc.usda.gov]  
**Sent:** Thursday, January 14, 2010 11:06 AM  
**To:** Glen Martin  
**Subject:** RE: Yerrick Creek Cultural Resource Report OHA Coversheet

Hi Glen, Thanks for the updated EA. Attached is a copy of the S106 letters, which were submitted yesterday to the SHPO and tribes. Once I am able to scan attachments 1-3, I'll email them to you as well.

Lauren.

---

**From:** Glen Martin [mailto:glen.m@aptalaska.com]  
**Sent:** Thursday, January 14, 2010 1:08 PM  
**To:** Dean, Laura - Washington, DC; McGee, Lauren - Washington, DC  
**Subject:** RE: Yerrick Creek Cultural Resource Report OHA Coversheet

Laura and Lauren,

I have attached the EA with your comments incorporated. The Cultural Resource section is highlighted in yellow for you to insert language, as you suggested. We will be submitting our Corp of Engineer permit application (our engineer informs me I will have the civil drawings sometime tomorrow) on Monday next week. This is the last permit to be applied for. DNR indicated they would begin processing our permit application last month and it is possible they are waiting for the COE to public notice. The blank part of the EA (Section 6) is for comments from any permits, which at this time we only have from ADF&G.

I will forward to you a copy of the COE permit when I send it to them on Monday.

Please let me know if there is anything further we need to do at our end, otherwise I will just keep you posted on the permitting and forward notices, etc. as they occur.

Regards,

Glen

Glen D. Martin  
Project Manager  
AP&T  
(360) 385-1733 x122



# GENERAL AREA

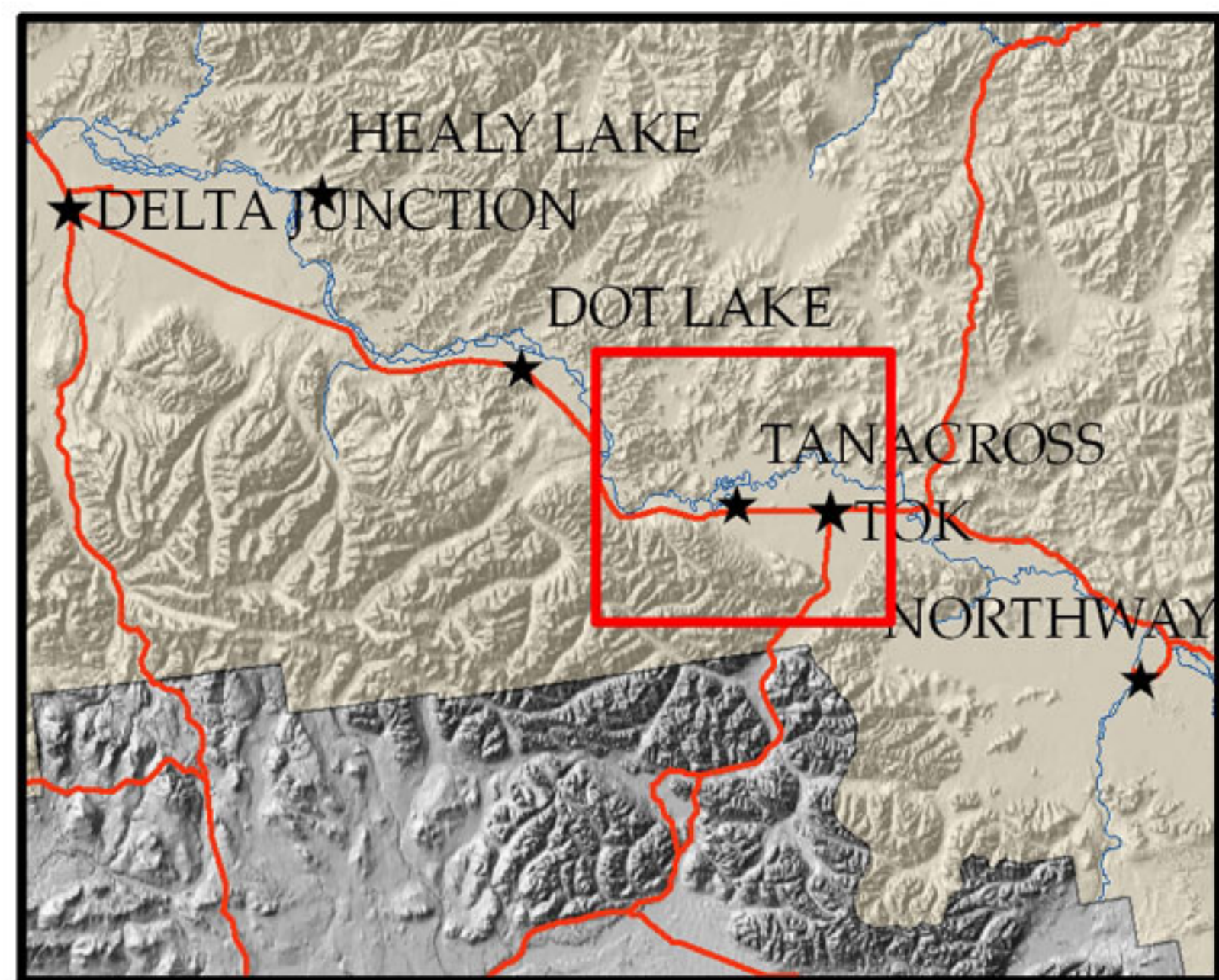

## LEGEND

- ★ Towns
- Roads
- ▭ Village Corporation Lands
- Doyon Lands
- Doyon Region

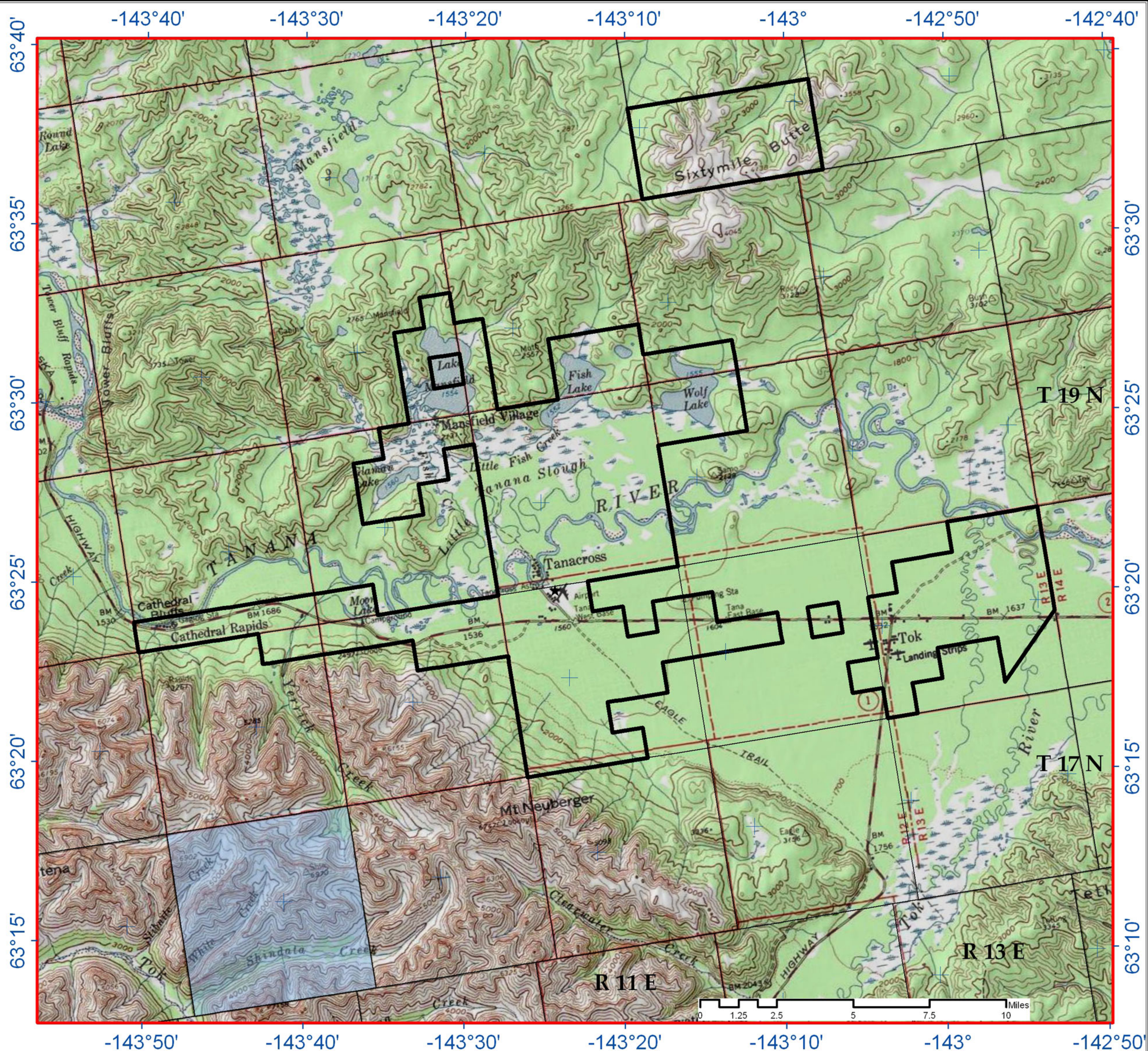

**TANACROSS**

Copper River Meridian  
Tanacross Quadrangle



(BLANK PAGE)



**United States Department of Agriculture  
Rural Development**

JAN 13 2010

Ms. Judith E. Bittner  
State Historical Preservation Officer  
Dept. of Natural Resources  
Office of History and Archaeology  
550 W. 7<sup>th</sup> Ave., Ste. 1310  
Anchorage, AK 99501

RE: Yerrick Creek Hydroelectric Project  
Section 106 Consultation, Determination of Effects  
File No.: 3130-4R AK Power and Telephone

Dear Ms. Bittner:

The Rural Utilities Service (RUS) has selected Alaska Power and Telephone Company as a finalist in its High Energy Cost Grant Program to construct the proposed Yerrick Creek Hydroelectric Project in Tanacross, Alaska. Awarding grant funds for the proposed project is an undertaking subject to review under Section 106 of the National Historic Preservation Act (16 U.S.C. § 470f) and its implementing regulations, "Protection of Historic Properties" (36 CFR Part 800).

Consultation History for the Project

In a letter dated July 9, 2008, the project proponent submitted an AHRIS Data Review report to the Alaska State Historic Preservation Office (Alaska SHPO) and requested technical assistance in determining if additional archaeological surveys should be needed (Attachment 1). The Alaska SHPO responded on August 15, 2008 (Attachment 1), concurring with the results of the report (i.e., additional surveys should occur in the access road, powerhouse, and penstock route area; no surveys should be needed near the impoundment). In addition, the Alaska SHPO requested that a federal agency initiate Section 106 consultation with its office.

RUS formally initiated Section 106 consultation with the Alaska SHPO in a letter dated October 14, 2009 (Attachment 2). Government-to-government consultation was also initiated by letter on this same date with the Native Village of Tanacross, Native Village of Tetlin, Village of Dot Lake, and Tanacross, Inc (Attachment 2). A subsequent teleconference was held on November 10, 2008,

1400 Independence Ave, S.W. · Washington DC 20250-0700  
Web: <http://www.rurdev.usda.gov>

Committed to the future of rural communities.

"USDA is an equal opportunity provider, employer and lender."  
To file a complaint of discrimination, write USDA, Director, Office of Civil Rights,  
1400 Independence Avenue, S.W., Washington, DC 20250-9410 or call (800) 795-3272 (Voice) or (202) 720-6382 (TDD).

to describe the proposed project and receive information about historic properties, in particular sites of cultural and religious significance, which may be affected by the proposed project. Written comments were received by Tanacross, Inc., on November 10, 2008, expressing concerns about impacts to a trail historical used by members of the Native Village of Tanacross. RUS formally responded to the letter on December 17, 2008, and also distributed copies of the meeting agenda and minutes on this same date (Attachment 3).

On December 17, 2008, RUS received a copy of a letter from the project proponent's attorney regarding Tanacross, Inc.'s November 10<sup>th</sup> letter. RUS formally responded to this letter on December 24, 2008, and submitted copies of this correspondence to the participants of the November 10<sup>th</sup> teleconference (Attachment 3).

Past these dates, no additional comments have been received from the Alaska SHPO, Native Village of Tanacross, Native Village of Tetlin, Village of Dot Lake, or Tanacross, Inc. regarding this project.

#### Proceeding Actions

Based on the comments received from participating parties, RUS directed the applicant to have surveys conducted to evaluate the potential effects of the proposed project to historic properties along the proposed access road, powerhouse, and penstock routes.

In August 2009, an archaeological survey was completed for these areas. The following sites were identified in the survey:

- TNX-156: Tanacross quadrangle segment of the Haines-Fairbanks pipeline
- TNX-074: Yerrick Creek cabin
- TNX-211: Can Dump area
- TNX-212: Construction camp site

Information about these sites can found in Attachment 4. The project proponent treated all of these sites of eligible for inclusion in the National Register of Historic Places.

#### Determination of Effects

Because the project would be designed to avoid these sites, RUS has determined that the proposed project will have no affects to historic properties. RUS will not require the applicant to have monitoring conducted along the northern portion of the access road (or Penstock Segment 1 as referenced in Attachment 4) during construction of this portion of the proposed project.

RUS has advised the project proponent to involve RUS in future discussions of site eligibility for inclusion in the National Register of Historic Places (NRHP). The agency has concerns about some of the justifications presented in Attachment 4, which are the basis for the consultant's recommendation.

RUS requests the Alaska SHPO's written concurrence with the above determination of effects within 30 days of this submittal. If you have any questions or need additional information about the proposed project, please contact Ms. Lauren McGee, Environmental Scientist at 202-720-1482 or [lauren.mcgee@wdc.usda.gov](mailto:lauren.mcgee@wdc.usda.gov).

Sincerely,



MARK S. PLANK  
Director  
Engineering and Environmental Staff  
USDA, Rural Utilities Service

Enclosures:

- Attachment 1: Pre-consultation comments from the Alaska SHPO
- Attachment 2: Letters to the Alaska SHPO and Native Villages Initiating Consultation
- Attachment 3: November 10, 2008, teleconference agenda and meeting minutes; comment from Tanacross, Inc., and RUS's response; RUS's response to the project proponent's letter dated November 25, 2008
- Attachment 4: 2009 Cultural Resource Survey of Alaska Power & Telephone's Yerrick Creek Hydroelectric Project near MP 1334 of the Alaska Highway, Alaska (November 2009) – completed by Northern Land Use Research, Inc.

cc:

Lauren McGee, RUS  
Laura Dean, RUS  
Glen Martin, AP&T



**United States Department of Agriculture  
Rural Development**

Mr. Robert Brean  
President  
Tanacross Inc.,  
General Delivery  
Tanacross, AK 99776

**JAN 13 2010**

RE: Yerrick Creek Hydroelectric Project  
Section 106 Consultation, Determination of Effects

Dear Mr. Brean:

The U.S. Department of Agriculture's Rural Utilities Service (RUS) has selected Alaska Power and Telephone Company as a finalist in its High Energy Cost Grant Program to construct the proposed Yerrick Creek Hydroelectric Project in Tanacross, Alaska. Awarding grant funds for the proposed project is an undertaking subject to review under Section 106 of the National Historic Preservation Act (16 U.S.C. § 470f) and its implementing regulations, "Protection of Historic Properties" (36 CFR Part 800).

Consultation History for the Project

Prior to RUS initiating government-to-government consultation with Tanacross, Inc., the project proponent submitted an AHRS Data Review report to the Alaska State Historic Preservation Office (Alaska SHPO) and requested technical assistance in determining if additional archaeological surveys would be needed (Attachment 1). The Alaska SHPO responded on August 15, 2008, concurring with the results of the report (Attachment 1). In addition, the Alaska SHPO requested that a federal agency initiate Section 106 consultation with its office.

In a letter dated October 14, 2009, RUS initiated government-to-government consultation with Tanacross, Inc., the Native Village of Tanacross, the Village of Dot Lake, and the Native Village of Tetlin (Attachment 2). RUS also initiated consultation with the Alaska SHPO by letter on this same date (Attachment 2). A subsequent teleconference was held on November 10, 2008, to describe the proposed project and receive information about historic properties, in particular sites of cultural and religious significance, which may be affected by the

1400 Independence Ave. S.W. · Washington DC 20250-0700  
Web: <http://www.rurdev.usda.gov>

Committed to the future of rural communities.

"USDA is an equal opportunity provider, employer and lender."  
To file a complaint of discrimination, write USDA, Director, Office of Civil Rights,  
1400 Independence Avenue, S.W., Washington, DC 20250-9410 or call (800) 795-3272 (Voice) or (202) 720-6382 (TDD).

proposed project. Written comments were received by Tanacross, Inc., on November 10, 2008, expressing concerns about impacts to a trail historically used by members of Tanacross. RUS formally responded to the letter on December 17, 2008, and distributed copies of the meeting agenda and minutes on this same date (Attachment 3).

On December 17, 2008, RUS received a letter from the project proponent's attorney regarding Tanacross, Inc.'s November 10<sup>th</sup> letter. RUS formally responded to this letter on December 24, 2008, and submitted copies of this correspondence to the participants of the November 10<sup>th</sup> teleconference (Attachment 3).

Past these dates, no additional comments have been received from the Native Village of Tanacross, Native Village of Tetlin, Village of Dot Lake, Tanacross, Inc., or Alaska SHPO regarding this project.

#### Proceeding Actions

Based on the comments received from participating parties, RUS directed the applicant to have surveys conducted to evaluate the potential effects of the proposed project to historic properties along the proposed access road, powerhouse, and penstock routes.

In August 2009, an archaeological survey was completed for these areas. The following sites were identified in the survey:

- TNX-156: Tanacross quadrangle segment of the Haines-Fairbanks pipeline
- TNX-074: Yerrick Creek cabin
- TNX-211: Can Dump area
- TNX-212: Construction camp site

Information about these sites can found in Attachment 4. The project proponent treated all of these sites of eligible for inclusion in the National Register of Historic Places.

#### Determination of Effects

Because the project would be designed to avoid these sites, RUS has determined that the proposed project will have no affects to historic properties. RUS will not require the applicant to have monitoring conducted along the northern portion of the access road (or Penstock Segment 1 as referenced in Attachment 4) during construction of the proposed project.

RUS has advised the project proponent to involve RUS in future discussions of site eligibility for inclusion in the National Register of Historic Places (NRHP).

We have concerns about some of the justifications presented in Attachment 4, which are the basis for the consultant's recommendation.

RUS requests that Tanacross, Inc., provides written concurrence with the above determination within 30 days of this submittal. If you have any questions or need additional information about the proposed project, please contact Ms. Lauren McGee, Environmental Scientist at [lauren.mcgee@wdc.usda.gov](mailto:lauren.mcgee@wdc.usda.gov) or 202-720-1482.

Sincerely,



MARK S. PLANK  
Director  
Engineering and Environmental Staff  
USDA, Rural Utilities Service

Enclosures:

- Attachment 1: Pre-consultation comments from the Alaska SHPO
- Attachment 2: Letters to the Alaska SHPO and Native Villages Initiating Consultation
- Attachment 3: November 10, 2008, teleconference agenda and meeting minutes; comment from Tanacross, Inc., and RUS's response; RUS's response to the project proponent's letter dated November 25, 2008
- Attachment 4: 2009 Cultural Resource Survey of Alaska Power & Telephone's Yerrick Creek Hydroelectric Project near MP 1334 of the Alaska Highway, Alaska (November 2009) – completed by Northern Land Use Research, Inc.

cc:

Lauren McGee, RUS  
Laura Dean, RUS  
Glen Martin, AP&T





**United States Department of Agriculture  
Rural Development**

**JAN 13 2010**

Mr. Donald Adams  
President  
Tetlin Village Council  
P.O. Box 388  
Tok, AK 99780

RE: Yerrick Creek Hydroelectric Project  
Section 106 Consultation, Determination of Effects

Dear Mr. Miller:

The U.S. Department of Agriculture's Rural Utilities Service (RUS) has selected Alaska Power and Telephone Company as a finalist in its High Energy Cost Grant Program to construct the proposed Yerrick Creek Hydroelectric Project in Tanacross, Alaska. Awarding grant funds for the proposed project is an undertaking subject to review under Section 106 of the National Historic Preservation Act (16 U.S.C. § 470f) and its implementing regulations, "Protection of Historic Properties" (36 CFR Part 800).

Consultation History for the Project

Prior to RUS initiating government-to-government consultation with the Native Village of Tetlin, the project proponent submitted an AHRIS Data Review report to the Alaska State Historic Preservation Office (Alaska SHPO) and requested technical assistance in determining if additional archaeological surveys would be needed (Attachment 1). The Alaska SHPO responded on August 15, 2008, concurring with the results of the report (Attachment 1). In addition, the Alaska SHPO requested that a federal agency initiate Section 106 consultation with its office.

In a letter dated October 14, 2009, RUS initiated government-to-government consultation with the Native Village of Tetlin, Dot Lake Village, Native Village of Tanacross, and Tanacross, Inc. (Attachment 2). RUS also initiated consultation with the Alaska SHPO by letter on this same date (Attachment 2). A subsequent teleconference was held on November 10, 2008, to describe the proposed project and receive information about historic properties, in particular sites of cultural and religious significance, which may be affected by the

1400 Independence Ave. S.W. · Washington DC 20250-0700  
Web: <http://www.rurdev.usda.gov>

Committed to the future of rural communities.

"USDA is an equal opportunity provider, employer and lender."  
To file a complaint of discrimination, write USDA, Director, Office of Civil Rights,  
1400 Independence Avenue, S.W., Washington, DC 20250-9410 or call (800) 795-3272 (Voice) or (202) 720-6382 (TDD).

proposed project. Written comments were received by Tanacross, Inc., on November 10, 2008, expressing concerns about impacts to a trail historically used by members of Tanacross. RUS formally responded to the letter on December 17, 2008, and distributed copies of the meeting agenda and minutes on this same date (Attachment 3).

On December 17, 2008, RUS received a letter from the project proponent's attorney regarding Tanacross, Inc.'s November 10<sup>th</sup> letter. RUS formally responded to this letter on December 24, 2008, and submitted copies of this correspondence to the participants of the November 10<sup>th</sup> teleconference (Attachment 3).

Past these dates, no additional comments have been received from the Native Village of Tanacross, Native Village of Tetlin, Village of Dot Lake, Tanacross, Inc., or Alaska SHPO regarding this project.

#### Proceeding Actions

Based on the comments received from participating parties, RUS directed the applicant to have surveys conducted to evaluate the potential effects of the proposed project to historic properties along the proposed access road, powerhouse, and penstock routes.

In August 2009, an archaeological survey was completed for these areas. The following sites were identified in the survey:

- TNX-156: Tanacross quadrangle segment of the Haines-Fairbanks pipeline
- TNX-074: Yerrick Creek cabin
- TNX-211: Can Dump area
- TNX-212: Construction camp site

Information about these sites can found in Attachment 4. The project proponent treated all of these sites of eligible for inclusion in the National Register of Historic Places.

#### Determination of Effects

Because the project would be designed to avoid these sites, RUS has determined that the proposed project will have no affects to historic properties. RUS will not require the applicant to have monitoring conducted along the northern portion of the access road (or Penstock Segment 1 as referenced in Attachment 4) during construction of the proposed project.

RUS has advised the project proponent to involve RUS in future discussions of site eligibility for inclusion in the National Register of Historic Places (NRHP).

We have concerns about some of the justifications presented in Attachment 4, which are the basis for the consultant's recommendation.

RUS requests that the Native Village of Tetlin provides written concurrence with the above determination within 30 days of this submittal. If you have any questions or need additional information about the proposed project, please contact Ms. Lauren McGee, Environmental Scientist at 202-720-1482 or [lauren.mcgee@wdc.usda.gov](mailto:lauren.mcgee@wdc.usda.gov).

Sincerely,

MARK S. PLANK  
Director  
Engineering and Environmental Staff  
USDA, Rural Utilities Service



Enclosures:

- Attachment 1: Pre-consultation comments from the Alaska SHPO
- Attachment 2: Letters to the Alaska SHPO and Native Villages Initiating Consultation
- Attachment 3: November 10, 2008, teleconference agenda and meeting minutes; comment from Tanacross, Inc., and RUS's response; RUS's response to the project proponent's letter dated November 25, 2008
- Attachment 4: 2009 Cultural Resource Survey of Alaska Power & Telephone's Yerrick Creek Hydroelectric Project near MP 1334 of the Alaska Highway, Alaska (November 2009) – completed by Northern Land Use Research, Inc.

cc:

Ms. Kristie Young, Native Village of Tetlin, Tribal Administrator  
Lauren McGee, RUS  
Laura Dean, RUS  
Glen Martin, AP&T



**United States Department of Agriculture  
Rural Development**

Mr. William J. Miller  
President  
Village of Dot Lake  
P.O. Box 2279  
Dot Lake, Alaska 99737

**JAN 13 2010**

RE: Yerrick Creek Hydroelectric Project  
Section 106 Consultation, Determination of Effects

Dear Mr. Miller:

The U.S. Department of Agriculture's Rural Utilities Service (RUS) has selected Alaska Power and Telephone Company as a finalist in its High Energy Cost Grant Program to construct the proposed Yerrick Creek Hydroelectric Project in Tanacross, Alaska. Awarding grant funds for the proposed project is an undertaking subject to review under Section 106 of the National Historic Preservation Act (16 U.S.C. § 470f) and its implementing regulations, "Protection of Historic Properties" (36 CFR Part 800).

Consultation History for the Project

Prior to RUS initiating government-to-government consultation with the Village of Dot Lake, the project proponent submitted an AHRIS Data Review report to the Alaska State Historic Preservation Office (Alaska SHPO) and requested technical assistance in determining if additional archaeological surveys would be needed (Attachment 1). The Alaska SHPO responded on August 15, 2008, concurring with the results of the report (Attachment 1). In addition, the Alaska SHPO requested that a federal agency initiate Section 106 consultation with its office.

In a letter dated October 14, 2009, RUS initiated government-to-government consultation with the Village of Dot Lake, Native Village of Tanacross, Native Village of Tetlin, and Tanacross, Inc. (Attachment 2). RUS also initiated consultation with the Alaska SHPO by letter on this same date (Attachment 2). A subsequent teleconference was held on November 10, 2008, to describe the proposed project and receive information about historic properties, in particular sites of cultural and religious significance, which may be affected by the

1400 Independence Ave. S.W. · Washington DC 20250-0700  
Web: <http://www.rurdev.usda.gov>

Committed to the future of rural communities.

"USDA is an equal opportunity provider, employer and lender."  
To file a complaint of discrimination, write USDA, Director, Office of Civil Rights,  
1400 Independence Avenue, S.W., Washington, DC 20250-9410 or call (800) 795-3272 (Voice) or (202) 720-6382 (TDD).

proposed project. Written comments were received by Tanacross, Inc., on November 10, 2008, expressing concerns about impacts to a trail historically used by members of Tanacross. RUS formally responded to the letter on December 17, 2008, and distributed copies of the meeting agenda and minutes on this same date (Attachment 3).

On December 17, 2008, RUS received a letter from the project proponent's attorney regarding Tanacross, Inc.'s November 10<sup>th</sup> letter. RUS formally responded to this letter on December 24, 2008, and submitted copies of this correspondence to the participants of the November 10<sup>th</sup> teleconference (Attachment 3).

Past these dates, no additional comments have been received from the Native Village of Tanacross, Native Village of Tetlin, Village of Dot Lake, Tanacross, Inc., or Alaska SHPO regarding this project.

#### Proceeding Actions

Based on the comments received from participating parties, RUS directed the applicant to have surveys conducted to evaluate the potential effects of the proposed project to historic properties along the proposed access road, powerhouse, and penstock routes.

In August 2009, an archaeological survey was completed for these areas. The following sites were identified in the survey:

- TNX-156: Tanacross quadrangle segment of the Haines-Fairbanks pipeline
- TNX-074: Yerrick Creek cabin
- TNX-211: Can Dump area
- TNX-212: Construction camp site

Information about these sites can found in Attachment 4. The project proponent treated all of these sites of eligible for inclusion in the National Register of Historic Places.

#### Determination of Effects

Because the project would be designed to avoid these sites, RUS has determined that the proposed project will have no affects to historic properties. RUS will not require the applicant to have monitoring conducted along the northern portion of the access road (or Penstock Segment 1 as referenced in Attachment 4) during construction of the proposed project.

RUS has advised the project proponent to involve RUS in future discussions of site eligibility for inclusion in the National Register of Historic Places (NRHP).

We have concerns about some of the justifications presented in Attachment 4, which are the basis for the consultant's recommendation.

RUS requests that the Village of Dot Lake provides written concurrence with the above determination within 30 days of this submittal. If you have any questions or need additional information about the proposed project, please contact Ms. Lauren McGee, Environmental Scientist at [lauren.mcgee@wdc.usda.gov](mailto:lauren.mcgee@wdc.usda.gov) or 202-720-1482.

Sincerely,



MARK S. PLANK  
Director  
Engineering and Environmental Staff  
USDA, Rural Utilities Service

Enclosures:

- Attachment 1: Pre-consultation comments from the Alaska SHPO
- Attachment 2: Letters to the Alaska SHPO and Native Villages Initiating Consultation
- Attachment 3: November 10, 2008, teleconference agenda and meeting minutes; comment from Tanacross, Inc., and RUS's response; RUS's response to the project proponent's letter dated November 25, 2008
- Attachment 4: 2009 Cultural Resource Survey of Alaska Power & Telephone's Yerrick Creek Hydroelectric Project near MP 1334 of the Alaska Highway, Alaska (November 2009) – completed by Northern Land Use Research, Inc.

cc:

Charles Miller, Dot Lake Village, Tribal Administrator  
Lauren McGee, RUS  
Laura Dean, RUS  
Glen Martin, AP&T



**United States Department of Agriculture  
Rural Development**

JAN 13 2010

Mr. Roy Denny  
President  
Tanacross Village Council  
P.O. Box 284  
Tok, AK 99780

RE: Yerrick Creek Hydroelectric Project  
Section 106 Consultation, Determination of Effects

Dear Mr. Miller:

The U.S. Department of Agriculture's Rural Utilities Service (RUS) has selected Alaska Power and Telephone Company as a finalist in its High Energy Cost Grant Program to construct the proposed Yerrick Creek Hydroelectric Project in Tanacross, Alaska. Awarding grant funds for the proposed project is an undertaking subject to review under Section 106 of the National Historic Preservation Act (16 U.S.C. § 470f) and its implementing regulations, "Protection of Historic Properties" (36 CFR Part 800).

Consultation History for the Project

Prior to RUS initiating government-to-government consultation with the Native Village of Tanacross, the project proponent submitted an AHRS Data Review report to the Alaska State Historic Preservation Office (Alaska SHPO) and requested technical assistance in determining if additional archaeological surveys would be needed (Attachment 1). The Alaska SHPO responded on August 15, 2008, concurring with the results of the report (Attachment 1). In addition, the Alaska SHPO requested that a federal agency initiate Section 106 consultation with its office.

In a letter dated October 14, 2009, RUS initiated government-to-government consultation with the Native Village of Tanacross, Dot Lake Village, Native Village of Tetlin, and Tanacross, Inc. (Attachment 2). RUS also initiated consultation with the Alaska SHPO by letter on this same date (Attachment 2). A subsequent teleconference was held on November 10, 2008, to describe the proposed project and receive information about historic properties, in particular sites of cultural and religious significance, which may be affected by the

1400 Independence Ave, S.W. · Washington DC 20250-0700  
Web: <http://www.rurdev.usda.gov>

Committed to the future of rural communities.

"USDA is an equal opportunity provider, employer and lender."  
To file a complaint of discrimination, write USDA, Director, Office of Civil Rights,  
1400 Independence Avenue, S.W., Washington, DC 20250-9410 or call (800) 795-3272 (Voice) or (202) 720-6382 (TDD).

proposed project. Written comments were received by Tanacross, Inc., on November 10, 2008, expressing concerns about impacts to a trail historically used by members of Tanacross. RUS formally responded to the letter on December 17, 2008, and distributed copies of the meeting agenda and minutes on this same date (Attachment 3).

On December 17, 2008, RUS received a letter from the project proponent's attorney regarding Tanacross, Inc.'s November 10<sup>th</sup> letter. RUS formally responded to this letter on December 24, 2008, and submitted copies of this correspondence to the participants of the November 10<sup>th</sup> teleconference (Attachment 3).

Past these dates, no additional comments have been received from the Native Village of Tanacross, Native Village of Tetlin, Village of Dot Lake, Tanacross, Inc., or Alaska SHPO regarding this project.

#### Proceeding Actions

Based on the comments received from participating parties, RUS directed the applicant to have surveys conducted to evaluate the potential effects of the proposed project to historic properties along the proposed access road, powerhouse, and penstock routes.

In August 2009, an archaeological survey was completed for these areas. The following sites were identified in the survey:

- TNX-156: Tanacross quadrangle segment of the Haines-Fairbanks pipeline
- TNX-074: Yerrick Creek cabin
- TNX-211: Can Dump area
- TNX-212: Construction camp site

Information about these sites can found in Attachment 4. The project proponent treated all of these sites of eligible for inclusion in the National Register of Historic Places.

#### Determination of Effects

Because the project would be designed to avoid these sites, RUS has determined that the proposed project will have no affects to historic properties. RUS will not require the applicant to have monitoring conducted along the northern portion of the access road (or Penstock Segment 1 as referenced in Attachment 4) during construction of the proposed project.



RUS has advised the project proponent to involve RUS in future discussions of site eligibility for inclusion in the National Register of Historic Places (NRHP).

We have concerns about some of the justifications presented in Attachment 4, which are the basis for the consultant's recommendation.

RUS requests that the Native Village of Tanacross provides written concurrence with the above determination within 30 days of this submittal. If you have any questions or need additional information about the proposed project, please contact Ms. Lauren McGee, Environmental Scientist at 202-720-1482 or [lauren.mcgee@wdc.usda.gov](mailto:lauren.mcgee@wdc.usda.gov).

Sincerely,

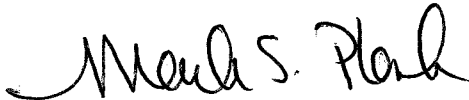

MARK S. PLANK  
Director  
Engineering and Environmental Staff  
USDA, Rural Utilities Service

Enclosures:

- Attachment 1: Pre-consultation comments from the Alaska SHPO
- Attachment 2: Letters to the Alaska SHPO and Native Villages Initiating Consultation
- Attachment 3: November 10, 2008, teleconference agenda and meeting minutes; comment from Tanacross, Inc., and RUS's response; RUS's response to the project proponent's letter dated November 25, 2008
- Attachment 4: 2009 Cultural Resource Survey of Alaska Power & Telephone's Yerrick Creek Hydroelectric Project near MP 1334 of the Alaska Highway, Alaska (November 2009) – completed by Northern Land Use Research, Inc.

cc:

Ms. Dawn Demit, Tanacross Village Council, Secretary  
Lauren McGee, RUS  
Laura Dean, RUS  
Glen Martin, AP&T

**Attachment 1**

Pre-consultation comments from the Alaska SHPO

SARAH PALIN, GOVERNOR

DEPARTMENT OF NATURAL RESOURCES

DIVISION OF PARKS AND OUTDOOR RECREATION

OFFICE OF HISTORY AND ARCHAEOLOGY

550 W. 7TH AVENUE, SUITE 1310  
ANCHORAGE, ALASKA 99501-3565  
PHONE: (907) 269-8721  
FAX: (907) 269-8908

August 15, 2008

File No.: 3130-4R AK Power & Telephone

SUBJECT: Yerrick Creek Hydroelectric Project  
Initiation of Section 106 consultation

Glen D. Martin  
Alaska Power & Telephone Company  
P. O. Box 3222  
Port Townsend, WA 98368

Dear Mr. Martin,

The Alaska State Historic Preservation Office received on July 9, 2008, your letter and the attached report *AHRS review and evaluation of cultural resources potential for Yerrick Creek Hydroelectric Project* by Patricia Browne. We have begun our review of your undertaking in accordance with Section 106 of the National Historic Preservation Act. Your letter does not indicate which federal or state agency is funding, permitting or licensing your project. Please ensure that we receive a cover letter regarding this project directly from the agency in accordance with *36 CFR 800.2(c)(3)*:

...the [Federal] agency official may use the services of applicants, consultants, or designees to prepare information, analysis and recommendations under this part. The agency official remains legally responsible for all required findings and determinations.

As stated in your letter, there is one reported Alaska Heritage Resources Survey (AHRS) site within the area of potential effect: TNX-074 (Yerrick Creek Cabin). Based on our records, TNX-074 was reported by archaeologists in 2002 during a linear survey oriented perpendicular to the current project; only a 60 meter wide swath of the current project area was included in the survey. Due to the presence of the historic cabin, the area has a high potential for additional historic remains. We recommend therefore, that the proposed access route, powerhouse site and penstock route be archaeologically surveyed. We agree with Ms. Browne that the impoundment area does not warrant a survey.

A color copy of the resulting survey report should be sent to our office along with an *Office of History and Archaeology: Cultural Resources Report Coversheet*. TNX-074 and any additional cultural resources reported by the survey should be evaluated for eligibility for the National Register of Historic Places. The effects of the project on eligible properties will need to be determined and any adverse effects mitigated.

Please contact Stefanie Ludwig at 269-8720 if you have any questions or if we can be of further assistance.

Sincerely,

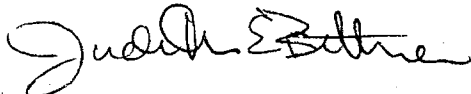
A handwritten signature in black ink, appearing to read "Judith E. Bittner". The signature is written in a cursive style with a large initial "J".

Judith E. Bittner  
State Historic Preservation Officer

JEB:sll

# ALASKA POWER & TELEPHONE COMPANY

P.O. BOX 3222 • 193 OTTO STREET  
PORT TOWNSEND, WA 98368  
(360) 385-1733 • (800) 982-0136  
FAX (360) 385-5177

July 9, 2008

Judith E. Bittner, Chief  
State Historic Preservation Officer  
Alaska Department of Natural Resources  
Office of History & Archaeology  
555 W. 7<sup>th</sup> Ave., Ste. 1310  
Anchorage, AK 99501-3565

Re: Determination of Effect for Yerrick Creek Hydroelectric Project

Dear Ms. Bittner:

Enclosed is information on our proposed Yerrick Creek Hydroelectric Project, which is on Yerrick Creek approximately 20 miles west of Tok on the Alaska Highway. In June we had Patricia Browne, of Browne Research, conducted an AHRS Data Review and Evaluation of Cultural Resources Potential for this project. Her report is enclosed along with more recent communications about our moving the penstock route to the west side of Yerrick Creek where AHRS site TNX-074 exists. We would propose to have a buffer to bypass TNX-074, but seek your guidance as to what the minimum clearance would need to be. Further, we need to know if additional study needs to be conducted for this project based on the results of Ms. Browne's efforts. For clarification, Ms. Browne also evaluated the adjacent Cathedral Rapids Creek No. 1 as we were considering it as a potential site earlier in our investigations, but are now focused on just Yerrick Creek as the enclosed project maps should bear out. Ms. Browne's maps will therefore slightly differ.

Enclosed is a project description and maps of the project site with project features overlaid. Please let me know if there is any further information you may need to conduct your analysis. Would it be possible to have your comments or recommendations by the end of August 2008?

Sincerely,

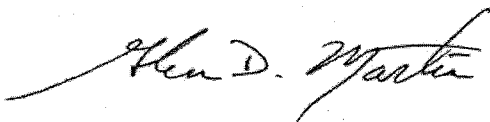

Glen D. Martin  
Project Manager  
(360)385-1733 x122  
(360)385-7538 fax  
[glen.m@aptalaska.com](mailto:glen.m@aptalaska.com)

**Attachment 2**

Letters to the Alaska SHPO and Native Villages Initiating Consultation



**United States Department of Agriculture  
Rural Development**

Ms. Judith E. Bittner  
State Historical Preservation Officer  
Dept. of Natural Resources  
Office of History and Archaeology  
550 W. 7<sup>th</sup> Ave., Ste. 1310  
Anchorage, AK 99501

RE: Yerrick Creek Hydroelectric Project  
Section 106 Consultation  
File No.: 3130-4R AK Power and Telephone

Dear Ms. Bittner:

The Rural Utilities Service (RUS), the agency that delivers the U.S. Department of Agriculture's Rural Development Utilities Programs, may provide assistance to the Yerrick Creek Hydroelectric Project pursuant to its High Energy Cost Grant Program, thereby making the referenced proposal an undertaking subject to review under Section 106 of the National Historic Preservation Act, 16 U.S.C. § 470f, and its implementing regulations, "Protection of Historic Properties" (36 CFR Part 800). The RUS is writing to initiate consultation with the Alaska State Historic Preservation Office (SHPO) pursuant 36 CFR § 800.3(c). Your willingness to assist the applicant, the Alaska Power and Telephone Company, in gathering information and preparing analyses needed to conduct the Section 106 review is appreciated.

As you are aware, the RUS is responsible for conducting government-to-government consultation with federally recognized Indian tribes. This is a responsibility that cannot be delegated to a nonfederal party without the consent of the tribe. Accordingly, the RUS has initiated government-to-government consultation with the Native Village of Tanacross, Native Village of Tetlin, and Village of Dot Lake.

The analyses and recommendations that have been developed by the applicant are presented in the report titled *AHRS review and evaluation of cultural resources potential for Yerrick Creek Hydroelectric Project* by Patricia Browne. In addition to review by the SHPO, the RUS also is seeking comments on this report's recommendations from the Native Village of Tanacross, the Native Village of Tetlin, the Village of Dot Lake and Tanacross, Inc.

1400 Independence Ave. S.W. - Washington DC 20250-0700  
Web: <http://www.rurdev.usda.gov>

Committed to the future of rural communities.

"USDA is an equal opportunity provider, employer and lender."  
To file a complaint of discrimination, write USDA, Director, Office of Civil Rights,  
1400 Independence Avenue, S.W., Washington, DC 20250-9410 or call (800) 795-3272 (Voice) or (202) 720-6382 (TDD).

According to your August 15, 2008 letter to the applicant, the Alaska SHPO agrees with the report's recommendation that the impoundment area does not warrant archeological survey. You also have recommended that additional work, specifically archeological survey, is needed in the immediate area surrounding the Yerrick Creek Cabin (TNX-074). Due to the presence of the cabin, this is an area with a high potential for historic properties to be identified. Archeological survey of that portion of the area surrounding the cabin, including the proposed access and penstock routes, and powerhouse site, currently is underway. As soon as the work has been completed, I will provide you with a copy of the results of the archeological survey accompanied by RUS's determination of eligibility and, as appropriate, effect for your review.

The RUS will host a teleconference to discuss project issues and progress, including Section 106 review, on November 13, 2008 at 10:00 am AST. I am formally inviting the Alaska SHPO to participate in this meeting. Other invited participants include the Alaska Power and Telephone Company, the Native Village of Tanacross, the Village of Dot Lake and Tanacross, Inc. Please respond to this invitation as soon as possible or no later than Thursday, November 6, 2008 by contacting Lauren McGee at 202-720-1482 or via email to [lauren.mcgee@wdc.usda.gov](mailto:lauren.mcgee@wdc.usda.gov).

Should you have any questions or require additional information, please contact Lauren McGee, Environmental Scientist, at 202-720-1482.

Sincerely,



**OCT 14 2008**

MARK S. PLANK  
Director  
Engineering and Environmental Staff  
USDA, Rural Development, Utilities Programs

cc: Laura Dean, Federal Preservation Officer, USDA Rural Development  
Lauren McGee, Environmental Scientist, USDA Rural Development  
Glen Martin, Project Manager, Alaska Power and Telephone Co.





**United States Department of Agriculture  
Rural Development**

Mr. Raymond Dennis  
Dot Lake Village Council, President  
P.O. Box 2279  
Dot Lake, AK 99737

RE: Yerrick Creek Hydroelectric Project

Dear Mr. Dennis:

The Rural Utilities Service (RUS), the agency that delivers the U.S. Department of Agriculture's Rural Development Utilities Programs, has selected the Alaska Power and Telephone Company's Yerrick Creek Hydroelectric Project located in Southeast Fairbanks County, Alaska as a finalist for financial assistance pursuant to its High Energy Cost Grant Program. This selection makes the referenced proposal an undertaking subject to review under Section 106 of the National Historic Preservation Act), 16 U.S.C. § 470f, and its implementing regulations, "Protection of Historic Properties" (36 CFR Part 800). The project proposes to construct a run-of-river hydroelectric dam, penstock, powerhouse, access road, substation, and transmission line. It will generate approximately 2.3 megawatts of power for the community of Tok, and the Village of Dot Lake, and the Native Villages of Tanacross and Tetlin.

The RUS is writing to initiate consultation with the Village of Dot Lake in accordance with 36 CFR Part 800. The village council's prior cooperation with the applicant, the Alaska Power and Telephone Company, in developing the information and analyses needed for Section 106 review is greatly appreciated. The RUS, however, is mindful of its responsibility to conduct government-to-government consultation with the Village of Dot Lake. This responsibility cannot be delegated to a nonfederal party without the village's consent. Accordingly, the RUS will conduct consultation to ensure that Section 106 review progresses appropriately.

The area of potential effect (APE) for the referenced undertaking includes the proposed impoundment, the penstock route, the powerhouse site and access road. As currently proposed, the APE includes lands owned by the State of Alaska and Tanacross, Inc. A detailed project description (enclosure) and report,

1400 Independence Ave., S.W. Washington DC 20250-0700  
Web: <http://www.rurdev.usda.gov>

Committed to the future of rural communities

"USDA is an equal opportunity provider, employer and lender."  
To file a complaint of discrimination, write USDA, Director, Office of Civil Rights,  
1400 Independence Avenue, S.W., Washington, DC 20250-9410 or call (800) 795-3272 (Voice) or (202) 720-6382 (TDD)

*AHRS review and evaluation of cultural resources potential for Yerrick Creek Hydroelectric Project*, was submitted to the Alaska State Historic Preservation Office (SHPO) for review on July 9, 2008. The report contains restricted information that we are not permitted to distribute. It did find that the impoundment area did not warrant an archeological survey. The SHPO agreed with the report's recommendation and suggested an archeological survey for the remaining portions of the APE. An archaeological survey of the proposed access route, powerhouse site and penstock route currently is underway.

Please review the enclosed report and provide RUS with the village council's comments as soon as possible or within thirty (30) days of receipt. The RUS will take into account any timely comments received. As soon as the work has been completed, I will provide the Village of Dot Lake with a copy of the results of the archeological survey accompanied by RUS's determination of eligibility and, as appropriate, effect for your review.

The RUS will host a teleconference to discuss project issues and progress, including Section 106 review, on November 13, 2008 at 10:00 am AST. I am formally inviting the Village of Dot Lake to participate in this meeting. Other invited participants include the Alaska SHPO, the Alaska Power and Telephone Company, the Native Village of Tetlin, the Native Village of Tanacross, and Tanacross, Inc. Please respond to this invitation as soon as possible or no later than Thursday, November 6, 2008 by contacting Lauren McGee at 202-720-1482 or via email to [lauren.mcgee@wdc.usda.gov](mailto:lauren.mcgee@wdc.usda.gov).

Should you have any questions or require additional information, please contact Lauren McGee, Environmental Scientist, at 202-720-1482.

Sincerely,

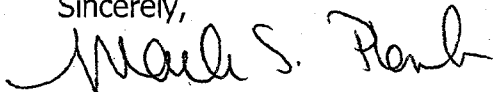

OCT 14 2008

MARK PLANK

Director

Engineering and Environmental Staff  
Water and Environmental Programs

Enclosure: Project Description and Maps for Yerrick Creek Hydroelectric Project

cc: Laura Dean, Federal Preservation Officer, USDA Rural Development  
Lauren McGee, Environmental Scientist, USDA Rural Development  
Glen Martin, Project Manager, Alaska Power and Telephone Co.  
Dot Lake Village Council Members and Tribal Administrator



**United States Department of Agriculture  
Rural Development**

Mr. Donald Adams  
Tetlin Village Council, President  
P.O. Box 797  
Tok, AK 99780

RE: Yerrick Creek Hydroelectric Project

Dear Mr. Adams:

The Rural Utilities Service (RUS), the agency that delivers the U.S. Department of Agriculture's Rural Development Utilities Programs, has selected the Alaska Power and Telephone Company's Yerrick Creek Hydroelectric Project located in Southeast Fairbanks County, Alaska as a finalist for financial assistance pursuant to its High Energy Cost Grant Program. This selection makes the referenced proposal an undertaking subject to review under Section 106 of the National Historic Preservation Act), 16 U.S.C. § 470f, and its implementing regulations, "Protection of Historic Properties" (36 CFR Part 800). The project proposes to construct a run-of-river hydroelectric dam, penstock, powerhouse, access road, substation, and transmission line. It will generate approximately 2.3 megawatts of power for the community of Tok, and the Village of Dot Lake, and the Native Villages of Tanacross and Tetlin.

The RUS is writing to initiate consultation with the Native Village of Tetlin in accordance with 36 CFR Part 800. The village council's prior cooperation with the applicant, the Alaska Power and Telephone Company, in developing the information and analyses needed for Section 106 review is greatly appreciated. The RUS, however, is mindful of its responsibility to conduct government-to-government consultation with the Native Village of Tetlin. This responsibility cannot be delegated to a nonfederal party without the village's consent. Accordingly, the RUS will conduct consultation to ensure that Section 106 review progresses appropriately.

The area of potential effect (APE) for the referenced undertaking includes the proposed impoundment, the penstock route, the powerhouse site and access road. As currently proposed, the APE includes lands owned by the State of Alaska and Tanacross, Inc. A detailed project description (enclosure) and report,

1400 Independence Ave., S.W. Washington DC 20250-0700  
Web: <http://www.rurdev.usda.gov>

Committed to the future of rural communities.

USDA is an equal opportunity provider, employer and lender.  
To file a complaint of discrimination, write USDA, Director, Office of Civil Rights,  
1400 Independence Avenue, S.W., Washington, DC 20250-9410 or call (800) 795-3272 (Voice) or (202) 720-6382 (TDD).

*AHRS review and evaluation of cultural resources potential for Yerrick Creek Hydroelectric Project*, was submitted to the Alaska State Historic Preservation Office (SHPO) for review on July 9, 2008. The report contains restricted information that we are not permitted to distribute. It did find that the impoundment area did not warrant an archeological survey. The SHPO agreed with the report's recommendation and suggested an archeological survey for the remaining portions of the APE. An archaeological survey of the proposed access route, powerhouse site and penstock route currently is underway.

Please review the enclosed report and provide RUS with the village council's comments as soon as possible or within thirty (30) days of receipt. The RUS will take into account any timely comments received. As soon as the work has been completed, I will provide the Native Village of Tetlin with a copy of the results of the archeological survey accompanied by RUS's determination of eligibility and, as appropriate, effect for your review.

The RUS will host a teleconference to discuss project issues and progress, including Section 106 review, on November 13, 2008 at 10:00 am AST. I am formally inviting the Native Village of Tetlin to participate in this meeting. Other invited participants include the Alaska SHPO, the Alaska Power and Telephone Company, the Native Village of Tanacross, the Village of Dot Lake, and Tanacross, Inc. Please respond to this invitation as soon as possible or no later than Thursday, November 6, 2008 by contacting Lauren McGee at 202-720-1482 or via email to [lauren.mcgee@wdc.usda.gov](mailto:lauren.mcgee@wdc.usda.gov).

Should you have any questions or require additional information, please contact Lauren McGee, Environmental Scientist, at 202-720-1482.

Sincerely,



**OCT 14 2008**

MARK PLANK  
Director  
Engineering and Environmental Staff  
Water and Environmental Programs

Enclosure: Project Description and Maps for Yerrick Creek Hydroelectric Project

cc: Laura Dean, Federal Preservation Officer, USDA Rural Development  
Lauren McGee, Environmental Scientist, USDA Rural Development  
Glen Martin, Project Manager, Alaska Power and Telephone Co.  
Tetlin Village Council Members



**United States Department of Agriculture  
Rural Development**

Mr. Roy Denny  
Tanacross Village Council, President  
P.O. Box 284  
Tok, AK 99780

RE: Yerrick Creek Hydroelectric Project

Dear Mr. Denny:

The Rural Utilities Service (RUS), the agency that delivers the U.S. Department of Agriculture's Rural Development Utilities Programs, has selected the Alaska Power and Telephone Company's Yerrick Creek Hydroelectric Project located in Southeast Fairbanks County, Alaska as a finalist for financial assistance pursuant to its High Energy Cost Grant Program. This selection makes the referenced proposal an undertaking subject to review under Section 106 of the National Historic Preservation Act, 16 U.S.C. § 470f, and its implementing regulations, "Protection of Historic Properties" (36 CFR Part 800). The project proposes to construct a run-of-river hydroelectric dam, penstock, powerhouse, access road, substation, and transmission line. It will generate approximately 2.3 megawatts of power for the community of Tok, and the Village of Dot Lake, and the Native Villages of Tanacross and Tetlin.

The RUS is writing to initiate consultation with the Native Village of Tanacross in accordance with 36 CFR Part 800. The village council's prior cooperation with the applicant, the Alaska Power and Telephone Company, in developing the information and analyses needed for Section 106 review is greatly appreciated. The RUS, however, is mindful of its responsibility to conduct government-to-government consultation with the Native Village of Tanacross. This responsibility cannot be delegated to a nonfederal party without the village's consent. Accordingly, the RUS will conduct consultation to ensure that Section 106 review progresses appropriately.

The area of potential effect (APE) for the referenced undertaking includes the proposed impoundment, the penstock route, the powerhouse site and access road. As currently proposed, the APE includes lands owned by the State of Alaska and Tanacross, Inc. A detailed project description (enclosure) and report,

1400 Independence Ave. S.W. Washington DC 20250-0700  
Web: <http://www.rurdev.usda.gov>

Committed to the future of rural communities

"USDA is an equal opportunity provider, employer and lender."  
To file a complaint of discrimination, write USDA, Director, Office of Civil Rights,  
1400 Independence Avenue, S.W., Washington, DC 20250-9410 or call (800) 795-3272 (Voice) or (202) 720-6382 (TDD).

*AHRS review and evaluation of cultural resources potential for Yerrick Creek Hydroelectric Project*, was submitted to the Alaska State Historic Preservation Office (SHPO) for review on July 9, 2008. The report contains restricted information that we are not permitted to distribute. It did find that the impoundment area did not warrant an archeological survey. The SHPO agreed with the report's recommendation and suggested an archeological survey for the remaining portions of the APE. An archaeological survey of the proposed access route, powerhouse site and penstock route currently is underway.

Please review the enclosed project description and provide RUS with the village council's comments as soon as possible or within thirty (30) days of receipt. The RUS will take into account any timely comments received. As soon as the work has been completed, I will provide the Native Village of Tanacross with a copy of the results of the archeological survey accompanied by RUS's determination of eligibility and, as appropriate, effect for your review.

The RUS will host a teleconference to discuss project issues and progress, including Section 106 review, on November 13, 2008 at 10:00 am AST. I am formally inviting the Native Village of Tanacross to participate in this meeting. Other invited participants include the Alaska SHPO, the Alaska Power and Telephone Company, the Native Village of Tetlin, the Village of Dot Lake, and Tanacross, Inc. Please respond to this invitation as soon as possible or no later than Thursday, November 6, 2008 by contacting Lauren McGee at 202-720-1482 or via email to [lauren.mcgee@wdc.usda.gov](mailto:lauren.mcgee@wdc.usda.gov).

Should you have any questions or require additional information, please contact Lauren McGee, Environmental Scientist, at 202-720-1482.

Sincerely,

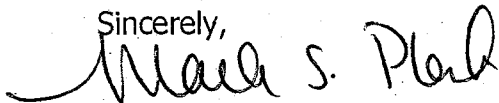

OGI 11 4 2008

MARK PLANK  
Director  
Engineering and Environmental Staff  
Water and Environmental Programs

Enclosure: Project Description and Maps for Yerrick Creek Hydroelectric Project

cc: Laura Dean, Federal Preservation Officer, USDA Rural Development  
Lauren McGee, Environmental Scientist, USDA Rural Development  
Glen Martin, Project Manager, Alaska Power and Telephone Co.  
Tanacross Village Council Members



**United States Department of Agriculture  
Rural Development**

Mr. Robert Brean  
President  
Tanacross, Inc.  
General Delivery  
Tanacross, AK 99776

RE: Yerrick Creek Hydroelectric Project

Dear Mr. Brean:

The Rural Utilities Service (RUS), the agency that delivers the U.S. Department of Agriculture's Rural Development Utilities Programs, has selected the Alaska Power and Telephone Company's Yerrick Creek Hydroelectric Project located in Southeast Fairbanks County, Alaska as a finalist for financial assistance pursuant to its High Energy Cost Benefit Grant Program. This selection makes the referenced proposal an undertaking subject to review under Section 106 of the National Historic Preservation Act), 16 U.S.C. § 470f, and its implementing regulations, "Protection of Historic Properties" (36 CFR Part 800). The proposal proposes to construct a run-of-river hydroelectric dam, penstock, powerhouse, access road, substation, and transmission line. It will generate approximately 2.3 megawatts of power for the community of Tok, and the Native Villages of Dot Lake, Tanacross, and Tetlin.

Since a portion of the proposal may occur on lands owned the corporation, the RUS is writing to initiate consultation with Tanacross, Inc. The corporation's prior cooperation with the applicant, the Alaska Power and Telephone Company, in developing the information and analyses needed for Section 106 review is greatly appreciated.

The area of potential effect (APE) for the referenced undertaking includes the proposed impoundment, the penstock route, the powerhouse site and access road. As currently proposed, the APE includes lands owned by the State of Alaska and Tanacross, Inc. A detailed project description (enclosure) and report, *AHRS review and evaluation of cultural resources potential for Yerrick Creek*

1400 Independence Ave. S.W. Washington DC 20250-0700  
Web: <http://www.rurdev.usda.gov>

Committed to the future of rural communities

"USDA is an equal opportunity provider, employer and lender."  
To file a complaint of discrimination, write USDA, Director, Office of Civil Rights,  
1400 Independence Avenue, S.W. Washington, DC 20250-9410 or call (800) 795-3272 (Voice) or (202) 720-6382 (TDD)

*Hydroelectric Project*, was submitted to the Alaska State Historic Preservation Office (SHPO) for review on July 9, 2008. The report contains restricted information that we are not permitted to distribute. It did find that the impoundment area did not warrant an archeological survey. The SHPO agreed with the report's recommendation and suggested an archeological survey for the remaining portions of the APE. An archaeological survey of the proposed access route, powerhouse site and penstock route currently is underway.

Please review the enclosed report and provide RUS with the corporation's comments as soon as possible or within thirty (30) days of receipt. The RUS will take into account any timely comments received. As soon as the work has been completed, I will provide Tanacross, Inc. with a copy of the results of the archeological survey accompanied by RUS's determination of eligibility and, as appropriate, effect for your review.

The RUS will host a teleconference to discuss project issues and progress, including Section 106 review, on November 13, 2008 at 10:00 am AST. I am formally inviting Tanacross, Inc. to participate in this meeting. Other invited participants include the Alaska SHPO, the Alaska Power and Telephone Company, the Native Village of Tanacross, the Native Village of Tetlin, and the Village of Dot Lake. Please respond to this invitation as soon as possible or no later than Thursday, November 6, 2008 by contacting Lauren McGee at 202-720-1482 or via email to [lauren.mcgee@wdc.usda.gov](mailto:lauren.mcgee@wdc.usda.gov).

Should you have any questions or require additional information, please contact Lauren McGee, Environmental Scientist, at 202-720-1482.

Sincerely,

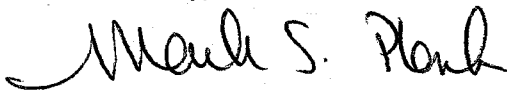

OCT 14 2008

MARK PLANK  
Director  
Engineering and Environmental Staff  
Water and Environmental Programs

cc: Laura Dean, Federal Preservation Officer, USDA Rural Development  
Lauren McGee, Environmental Scientist, USDA Rural Development  
Glen Martin, Project Manager, Alaska Power and Telephone Co.  
Tanacross, Inc., Board Members



**Attachment 3**

11/10/ 2008 Teleconference Agenda and Meeting Minutes

Comment from Tanacross, Inc., & RUS's response

RUS's response to the project proponent's letter dated 11/25/2008

**McGee, Lauren - Washington, DC**

---

**From:** McGee, Lauren - Washington, DC  
**Sent:** Wednesday, December 17, 2008 1:09 PM  
**To:** akmadindian@yahoo.com; Bob Brean; dawndemit@hotmail.com; Dean, Laura - Washington, DC; dolly.h@aptalaska.com; 'Eric Hannan'; 'Glen Martin'; 'John Harvey'; kristie\_young\_ak@yahoo.com; Larsen, Karen - Washington, DC  
**Subject:** 11/13/2008 Yerrick Creek Mtg Summary  
**Attachments:** Yerrick Creek mtg agenda.pdf; Yerrick Creek Mtg Summary.pdf; Yerrick Creek preliminary archaeolog rpt.pdf; APC Hydroelectric projects.pdf; Tanacross Inc comment 1.pdf; RUS Tanacross Inc response.pdf

Hi All,

I apologize for the delay in submitting RUS's summary notes for the Yerrick Creek teleconference (11/13/2008). In addition to the notes, a copy of the following is attached:

- teleconference agenda
- preliminary archaeological survey
- synopsis of AP&T's successful hydroelectric projects
- Tanacross, Inc.'s letter re: the potential impacts of the proposal
- RUS's response to Tanacross, Inc.'s letter

If you have any questions about the meeting notes or suggest revisions, please email me or call me at 202.720.1482. Thank you for your participation. We will keep you updated on the progression of the Yerrick Creek proposal.

Regards,

Lauren.

Lauren McGee, Environmental Scientist  
USDA, Rural Development Utilities Programs  
Mail Stop 1571, Rm 2239  
1400 Independence Ave, SW  
Washington, DC 20250  
202.720.1482 (phone)  
202.690.0649 (fax)  
[lauren.mcgee@wdc.usda.gov](mailto:lauren.mcgee@wdc.usda.gov)  
<http://www.usda.gov/rus/water/ees/environ.htm>

12/17/2008

Yerrick Creek Hydroelectric Project Teleconference  
Thursday, November 13, 2008, 10:00 AM AST (90 minutes)  
Draft Agenda

Dial-in teleconference number: (800) 867-6144  
User code: 6856

Meeting Moderators: Lauren McGee, Environmental Scientist, Rural Development  
Laura Dean, Archeologist and Federal Preservation Officer, Rural Development

Participants: USDA, Rural Development, Utility Programs (RD)  
Alaska Power and Telephone Company (APTC)  
Native Village of Tanacross  
Tanacross, Inc.  
Native Village of Tetlin  
Village of Dot Lake

Discussion Items

<u>Topic</u>	<u>Speaker(s)</u>
Introductions	All
Overview of the High Energy Cost Grant program	RD
Purpose of Meeting	
National Env. Policy Act (NEPA) requirements	RD
National Historic Preservation Act - Section 106 requirements	
Project Description	
Purpose	
Alternatives	APTC
Preferred Alternative	
Status of Studies being Conducted	
Discussion	All
Next Steps	All

**Yerrick Creek Hydroelectric Teleconference Meeting Summary**  
**11/13/2008, 10:00 AM – 11:00 AM AST**

Participants:

Rural Utilities Service (RUS)

Lauren McGee, Environmental Scientist and Moderator	202-720-1482
Karen Larsen, Management Analyst, Electric Programs	202-720-8787
Laura Dean, Archeologist and Federal Preservation Officer	202-720-9634

Tanacross, Inc.

Robert Brean, President  
Bruce Moore, Attorney  
Meg Hass, Land consultant

Native Village of Tanacross

Dawn Demit, Village Council Secretary

Native Village of Dot Lake

Charles Miller, Tribal Administrator

Native Village of Tetlin

Kristie Young, Tribal Administrator

Alaska Power & Telephone Company (APTC)

Glen Miller, Project Manager  
Eric Hannan, Interior Division Manager and Engineer  
John Harvey  
Dolly Henton, Administrative Assistant/GIS Specialist

---

*\*Notes: (1) Summary is organized according to topic. (2) Details shown in bold, red font indicate uncertainty.*

Introduction of participants

Overview of High Cost Energy Grant Program

- Program began approximately eight years ago.
- Funds can be used for energy generation (including renewables), transmission, distribution, and efficiency improvement proposals.
- APTC's Yerrick Creek proposal received a relatively high ranking and was selected as a potential award recipient for Fiscal Year (FY) 2007 funding.
- Final approval of the proposal is pending completion of all environmental requirements, including compliance with the National Environmental Policy Act (NEPA) and Section 106 of the National Historic Preservation Act and its implementing regulations (36 CFR Part 800).

Purpose of the meeting

- NEPA requirements
  - APTC must complete an environmental impact report compliant with RUS regulations (7 CFR Part 1794) prior to receiving funding.

- The proposal has been classified as an Environmental Assessment (EA) as it would be a new generating facility producing less than 20 MW (§ 1794.23[3]).
  - Once an Environmental Report (ER) is prepared and approved by RUS, the ER would be adopted as RUS's EA and made available for public review. Notification of the ER's availability would occur in local newspapers. The ER would be available for download from RUS's website.
  - RUS would issue a Finding of No Significant Impact (FONSI) if few comments/objections to the proposal were received and if the ER showed that the proposal would not have significant impacts to the human environment. A notice indicating the availability of the FONSI would be published in local newspapers. An additional comment period following the publication of the FONSI would occur also as needed.
  - Tanacross Inc. has requested that all notices for this proposal be submitted by email as the region's local newspaper is only published bimonthly.
  - APTC is in the initial stages of preparing the Yerrick Creek ER. Several studies have commenced based on available literature and site conditions on Alaska State lands. No work has been initiated on Tanacross, Inc. lands.
- Requirements under Section 106 of the National Historic Preservation Act
- Under Section 106, RUS is required to take into account effects of its undertakings on historic properties. The APTC application is an undertaking subject to review under Section 106.
  - The Alaska SHPO serves in an advisory role in Section 106 review and is participating because lands others than tribal lands are involved.
  - Under Section 106, RUS has a responsibility to consult with other parties before reaching a decision on whether or not to provide assistance. This is the first consultation meeting held by the RUS about the APTC undertaking.
  - The Native Village of Tanacross is a federally recognized tribe by the Bureau of Indian Affairs. It is, therefore, the native village of Tanacross which is entitled to government-to-government consultation. However, the native corporation, Tanacross, Inc., owns most of the land and resources of the native village, and shares in the corporation are held by tribal members. Accordingly, Tanacross, Inc. also must participate in consultation since it reflects the interest of tribal members.
  - The letter dated November 10, 2008, from Mr. Bruce Moore, Tanacross Inc. attorney, identified the area of the proposed project as one possessing cultural value to Tanacross Inc. RUS recognizes that this area may contain properties of religious and cultural significance to Native Village of Tanacross, Tetlin and Dot Lake. That is why those parties were invited to consult. However, in order to proceed in its Section 106 review, RUS needs specific information about discrete places of significance to the tribes, such as the trail between Tanacross and the area of Metasta Lake identified in the November 10, 2008, letter.
  - RUS indicated that APTC has not yet conducted the fieldwork necessary to identify historic properties in the area of potential effects.

## Project Description:

- Overview
  - o APTC's methods for power generation have changed from predominately diesel to hydroelectric during the past two decades.
  - o Since the mid 1970s, APTC has considered Yerrick Creek a good site for hydroelectric power generation due to its relatively good hydraulic pressure.
  - o The proposal calls for the diversion of Yerrick Creek water to an 11,000-15,000 foot tunnel that is approximately six inches in diameter. The water exiting the tunnel (or pipe) would power a turbine. The pipe and supporting transmission lines would be buried. Existing transmission infrastructure along the highway would be used.
  - o The local community could see a 20% reduction in utility costs.
  
- Alternatives Considered by APTC:
  - o Electricity generation alternatives – APTC considered hydrokinetic (energy generation from water movement w/o the use of an impoundment or diversion), solar, thermal, and wind. APTC determined that these options would not be feasible as the proposed project area does not have high class wind speeds. Additionally, thermal pockets have not been identified near the proposed project area.
  - o Siting of hydro facilities – APTC has conducted kinetic studies in the Tanana River (a location alternative). This site was considered unfeasible due to river water siltation and bio-material (leaf) accumulation.
  
- Hydro and Migratory Fish Studies
  - o Migratory fish are present in Yerrick Creek. APTC has contacted Alaska State fish and wildlife agencies.
  - o Since water in Yerrick Creek does freeze during the winter, the facility can only run during 6-9 months of the year.
  - o Most water flow is subterranean.
  - o All stream gauging activities have occurred on Alaska State lands.

## General Discussion:

- Prior contact between APTC and Tanacross, Inc.
  - o **Sept/Oct/Nov 2006 (???)**: Tanacross, Inc. had a meeting with APTC. Tanacross, Inc. confirmed that it was not interested in leasing its land for use in the APTC proposal.
  - o **On January 8, 2008 (or 2007?)**, APTC sent a letter to Tanacross, Inc. regarding the lease of land under the control of Tanacross, Inc. for use by APTC's proposal. APTC acknowledged Tanacross, Inc.'s decision.
  - o Tanacross, Inc. did not at that time and currently does not support APTC's proposed use of its lands due to legal contracts and permits that commit the land in question for use in the proposed Denali pipeline project.

- Tanacross, Inc. conceded that it was up to Denali - The Alaska Gas Pipeline, LLC (Denali) to determine if its pipeline and the APTC proposal were compatible uses. However, Tanacross, Inc. would not yield its prior business commitment and do not currently support APTC contacting Denali to assess the feasibility of co-locating both projects on Tanacross, Inc. land.
  - Tanacross Inc. supports the development of cheap, renewable power. However, it is concerned with how APTC's proposal might change the land and the important resources it contains.
  - According to APTC, if Tanacross, Inc. land is not available for use, then the project cannot be constructed as proposed. That means that continued use of diesel generation (the 'No build" alternative) would be the only feasible option.
  - Tanacross, Inc. also is concerned about the multiple documents which state that **Tanacross Village and/or Tanacross, Inc.** is in favor of the APTC proposal.
- Mail/email announcements:
    - Because the local newspaper is printed only bimonthly, Tanacross, Inc. requested that notice of the availability of all documents associated with RUS's environmental review of this proposal be sent by email. This includes a copy of the preliminary archaeological report.
  - Financing of the proposal
    - Given project costs, construction of the proposal would not be possible without support from state and federal grants. APTC would not make a profit on this proposal.
  - Other views:
    - Tetlin and Dot Lake are in support of APTC's proposal.
  - Examples of successful hydroelectric proposals similar to Yerrick Creek
    - APTC discussed the South Fork Hydroelectric Project on Prince Wales Island as a good example.
    - APTC will produce a document for consulting parties of its successful hydroelectric projects.

Next steps:

- RUS will send a summary of this meeting's discussion, the preliminary archaeological survey, and examples of successful APTC hydroelectric proposals by email to consulting parties.

Prepared by: Lauren McGee and Laura Dean

Joseph M. Moran  
Michael C. Geraghty  
Patricia L. Zobel  
Deirdre Darling Ford  
Bruce A. Moore  
Adolf V. Zeman  
Danielle M. Ryman  
Nora G. Barlow  
Stephen S. DeLisio, *Of Counsel*

**Via E-Mail and U.S. Mail**

November 10, 2008

Mr. Mark Plank  
U.S. Department of Agriculture  
Rural Development Electric Programs  
1400 Independence Avenue, SW  
STOP 1560, Room 5165-South Building  
Washington D.C. 20250-1560

Re: Yerrick Creek Hydroelectric Proposal  
APC 2007RUS-01

Dear Mr. Plank:

Thank you for the opportunity to submit comments on this funding proposal. We represent Tanacross Inc. and submit these comments on its behalf. This is in fact the first time Tanacross Inc. has been provided with an opportunity to review any of the applications for this proposal. As I understand, this is only an application for pre-construction funding. Nonetheless, it disturbs me that this proposal has not included formal notice to the primary landowner. This is equally disturbing from the perspective of § 106 of the National Historic Preservation Act as the USDA was aware that the Yerrick Creek lands were selected by a Native village corporation in an area very close to the federally recognized Native Village of Tanacross. It should be presumed for § 106 analysis that this land has cultural, historic and subsistence value to Tanacross Inc. and the residents of the Native Village of Tanacross.

Active consultation with Tanacross Inc. is required by the National Historic Preservation Act and has been overlooked. At present, I have only had the opportunity to review your letter of October 14, 2008, and a 13 page portion of the grant application. Based on that limited information, and without waiving any objections Tanacross Inc. may have to the process so far, please consider the following initial comments regarding the hydroelectric proposal for Tanacross Inc. land at and around Yerrick Creek:

1. Tanacross Inc. is an Alaska Native Village corporation that selected land encompassing the lower portions of Yerrick Creek under the Alaska Native Claims



Mr. Mark Plank  
November 10, 2008  
Page 2

Settlement Act of December 18, 1971. The transfer of this land from the United States was accomplished by Interim Conveyance No. 1508, as recorded on May 21, 1992, in the Fairbanks Recorder's Office in Book 748, Page 0682 through 0692. I assume from the narrative provided in your letter and the application that approximately one half of the penstock route, construction and maintenance roads, and all of the powerhouse site, its access road and transmission facilities under this proposal would be located on land conveyed to Tanacross Inc. by Interim Conveyance No. 1508.

2. Neither Alaska Power and Telephone Company ("APT") nor its subsidiary, Alaska Power Company, has started substantive negotiations with Tanacross Inc. regarding a lease and easements for the construction and necessary facilities. Tanacross Inc. has not consented or agreed to the use of its land for this proposal. Informally, Tanacross Inc. has told APT it is not interested. It seems inappropriate for your agency to consider funding a proposal submitted by an applicant that does not have the right to use the land necessary for the project.

Is it USDA's intent to broker the negotiations between Tanacross Inc. and APT? In any case, USDA should have contacted Tanacross Inc. as a matter of law and common courtesy before conducting any on-the-ground survey of land belonging to Tanacross Inc. At this point, it does not seem possible for USDA to complete the legal requirements imposed by § 106 process without first turning over the information, reports and surveys you have gathered to date and then commencing active consulting with Tanacross Inc.

3. In specific regard to § 106, the proposed hydroelectric project would conflict with historic trails. Tribal members report historic use of the trail following Yerrick Creek connecting Tanacross to land and people in the area of Metasta Lake. *See also*, Henry T. Allen (1887) "Report of an Expedition to the Copper, Tanana, and Koyukuk Rivers in the Territory of Alaska in the Year 1885" Government Printing Office, Washington DC. Allen's map No. 3 shows a trail he calls the Mentasta Pass Trail heading west from the junction of the trails to Nandell's and to Ketchumstuck near Tanana Crossing (now Tanacross). The Interim Conveyance 1508 for the Yerrick Creek land selection contains a 25' trail easement for uses that do not include construction of this proposed project.

4. In further specific regard to § 106, the proposed hydroelectric project would conflict with subsistence use, namely hunting, harvesting birch bark, and berry picking. These historic and current uses will be impacted by increased public access that accompanies construction, road building and development. *See*, Walter Rochs Goldschmidt (1946) "Delimitation of Possessory Rights of the Villages of Tetlin, Tanacross, and Northway, Interior Alaska" unpublished report, 1946 (Library

Mr. Mark Plank  
November 10, 2008  
Page 3

reference: ARLIS SPEC COLL E 98 L3 G62; NARC Reference: RG: 75 file 30033-1943-308, part 5. 11E1, 3:2:5, Box 101).

Through interviews during the summer of 1946, the author outlined the area used for subsistence purposes by Tanacross People. The Yerrick Creek watershed is clearly within the area described on page 46. *See also*, Kenny Thomas, Sr., edited by Craig Mishler, (2005) "Crow is My Boss" University of Oklahoma Press: Norman. In extended interviews, Mr. Thomas describes the area formerly used for hunting sheep as "up here on the mountain" a place called "Sheep Place". He indicates that Tanacross people hunted sheep on the slopes of Mt. Neuberger, the headwaters of Yerrick Creek, at p. 193.

5. In regard to the deliberative process required by 36 CFR 800, there appear to be alternatives to the Yerrick Creek hydroelectric proposal that would not adversely impact these historic attributes of the land or create the legal problems we have identified below. For example, we understand that the applicant has considered an in-stream turbine that could be placed in the Tanana River (which flows year round) and would provide a similar supplement to the energy requirements of the local communities. This would have the advantage over the Yerrick Creek proposal of being away from the gas pipeline right of way, closer to the highway, and it would not require development of an 11,000 foot long construction and maintenance road over an historic trail and providing increased access to subsistence areas.

Your letter and the 13 page application do not address feasibility in any sense other than to detail the applicant's ability to complete the project. There is no information provided, for example, about stream flow levels, ground and soil structures, diversion of the stream bed during construction, or even general engineering and construction concerns that would accompany this kind of project. There is no way for the impacted landowner to evaluate the proposal from the information provided, and there is no meaningful way to engage in a discussion of the avoidance or resolution of adverse effects as described in § 800.

6. Finally, as legal matter, Tanacross Inc. already has commitments for this land. It appears from your letter and the 13 page application that the proposed hydroelectric project would directly interfere with the right-of-way being developed by Denali-The Alaska Gas Pipeline LLC ("Denali") for the transportation of North Slope natural gas to market. Permits have already been issued by Tanacross Inc. to Denali for land which includes the same Yerrick Creek area identified by the application. The powerhouse location in the APT application appears to be in the same location as a compressor station location in previous designs for the gas pipeline.

Mr. Mark Plank  
November 10, 2008  
Page 4

The development of the gas pipeline is a priority for Tanacross. It is fair to assume the gas pipeline is also a priority for the surrounding communities of Dot Lake, Tetlin and Tok. Constructing the gas pipeline is clearly a priority for the State of Alaska and is connected to broader federal commerce and energy plans. How does the applicant propose to address these conflicts?

These six points may not be an exhaustive list, but they will provide you with an introduction at this late date to the concerns Tanacross Inc. and its shareholders have with this proposal to use their land and with the agency process so far. I understand that APC has portrayed this issue in public comments as being Tanacross Inc.'s opposition to cleaner and cheaper electric services for the City of Tok. I assure you that is not the case.

Instead, Tanacross Inc. suggests that the issues are (a) what is the real cost of alleged cheaper electricity from this proposal in terms of adverse impact to the existing cultural, historical and subsistence attributes of the Yerrick Creek land; (b) what are the alternatives for electric power generation; (c) what are the possible measures to resolve adverse effects; (d) what is the benefit of this proposal in comparison to the benefits of a natural gas pipeline; (e) what is the legal impact of this proposal on the existing permits already issued to Denali; and (f) why fund this proposal over other meritorious, less problematic proposals.

If you have any questions after looking this letter over, please give me a call.

Sincerely yours,

DeLISIO MORAN GERAGHTY & ZOBEL, P.C.

By:



Bruce A. Moore

00156901.DOC

cc: Robert Brean, Tanacross Inc.  
Roy Denny, Tanacross Village Council  
Robert Grimm, Alaska Power & Telephone  
Judith Bittner, State Historic Office of Preservation  
Henry Ecton, FERC



United States Department of Agriculture  
Rural Development

DEC 17 2008

Mr. Robert Brean  
President, Tanacross, Inc.  
c/o Alaska Housing Finance Corporation  
4300 Boniface Parkway  
Anchorage, Alaska 99504

Re: Proposed Yerrick Creek Hydroelectric Project

Dear Mr. Brean:

Thank you for participating in the teleconference on November 14, 2008, that was conducted by the Rural Utilities Service (RUS), an agency that delivers the U.S. Department of Agriculture's Rural Development Utilities Program, to meet its responsibilities under the regulations (36 CFR Part 800) implementing Section 106 of the National Historic Preservation Act. As a follow-up to that meeting, the RUS would like to address several concerns which have been raised by the legal representative of Tanacross, Inc., Mr. Bruce Moore of DeLiso Moran Geraghty & Zobel, P.C. in a letter dated November 10, 2008.

As indicated during the recent teleconference, the referenced undertaking was selected for consideration of possible funding by RUS in response to an application submitted by Alaska Power and Telephone (APT). The High Energy Cost Grant Program was created by Congress in November 2000 as a new program under the Rural Electrification Act of 1936 (7 U.S.C. 918a) to provide financial assistance for the improvement of energy generation, transmission, and distribution facilities serving rural communities with home energy costs that are over 275 percent of the national average. This selection, however, does not guarantee that federal assistance will be forthcoming. That decision depends, among other things, on the outcome of review under National Environmental Policy Act (NEPA), and Section 106 and its implementing regulations. While the applicant for the referenced undertaking, APT, has gathered information about alternatives, pursuant to Section 106 and NEPA, a formal evaluation of the feasibility of these options has not yet been made by RUS. Through the recent teleconference and subsequent meetings, it is the intent of RUS to consult with Tanacross, Inc. as well as the Native Village of Tanacross and others before any alternative is selected for detailed evaluation.

The RUS is aware that the referenced undertaking proposes to use land which is controlled by Tanacross, Inc. Because of this factor and the possibility that the proposed project could affect historic properties (that is properties which are listed in or eligible for listing in the National Register of Historic Places) of religious and cultural significance to an Indian tribe, the RUS initiated consultation with Tanacross, Inc. and the Native Village of Tanacross by letter dated October 13, 2008. The November 10, 2008, letter, from your attorney asserts that "[t]here is no way for the impacted landowner (Tanacross, Inc.) to evaluate the information provided, and

1400 Independence Ave. S.W. Washington DC 20250-0700  
Web: <http://www.rurdev.usda.gov>

Committed to the future of rural communities

"USDA is an equal opportunity provider, employer and lender."

To file a complaint of discrimination, write USDA, Director, Office of Civil Rights,  
1400 Independence Avenue, S.W., Washington, DC 20250-9410 or call (800) 795-3272 (Voice) or (202) 720-6382 (TDD).

*there is no meaningful way to engage in a discussion of the avoidance or resolution of adverse effects."* However, the RUS at this time cannot provide specific information about historic properties located in the referenced undertaking's area of potential effects (APE) because the field studies on which such an evaluation would be based have not yet been initiated. Lacking identified historic properties in the APE, it is therefore premature to discuss the resolution of adverse effects.

In order to complete its identification effort in accordance with 36 CFR § 800.4, the RUS is seeking the assistance of consulting parties, especially Tanacross, Inc. and the Native Village of Tanacross. Your attorney's November 10, 2008, letter establishes that the broad area which includes the APE has "*cultural, historic and subsistence value to Tanacross Inc. and the residents of the Native Village of Tanacross.*" However, this information is too broad for the purposes of Section 106 review. Instead, the RUS is seeking information from you describing specific places of importance to Tanacross, Inc. and the Native Village of Tanacross with an explanation as to why such places may meet one or more of the four National Register criteria (36 CFR Part 63). The letter dated November 10, 2008, does identify one specific cultural resource, a trail that follows Yerrick Creek connecting Tanacross to Metasta Lake. The historical use of the trail by tribal members, however, while important information, is not sufficient in and of itself to qualify this resource as eligible for listing in the National Register.

Shortly, the consulting parties will receive via email the background study of the APE that was conducted by the applicant as a first step in identifying historic properties. The RUS encourages Tanacross, Inc. to review and provide comments on this study. Please contact the RUS directly if there is information which you might like to submit regarding possible historic properties within the APE that you would like to remain confidential.

The RUS looks forward to consulting with Tanacross Inc. and the Native Village of Tanacross regarding the referenced undertaking. Should you have any questions or require additional information, please contact Lauren McGee, Environmental Scientist, at 202-720-1482.

Sincerely,



MARK S. PLANK  
Director  
Engineering and Environmental Staff  
Water and Environmental Programs  
USDA, Rural Development, Utilities Programs

**McGee, Lauren - Washington, DC**

---

**From:** McGee, Lauren - Washington, DC  
**Sent:** Wednesday, December 24, 2008 11:18 AM  
**To:** Bob Brean; Fletcher, Linda; dawndemit@hotmail.com; kristie\_young\_ak@yahoo.com; akmadindian@yahoo.com; 'Glen Martin'; dolly.h@aptalaska.com; 'Eric Hannan'; 'John Harvey'  
**Cc:** Dean, Laura - Washington, DC; Larsen, Karen - Washington, DC  
**Subject:** RUS letter to Wellman's Yerrick Creek letter  
**Attachments:** yerrick wellman letter.PDF

Hi All, attached is a letter that RUS recently submitted to Ted Wellman, attorney for Alaska Power and Telephone Company and its subsidiary Alaska Power Company. It is regarding Wellman's November 25, 2008 letter submitted to Bruce Moore, attorney for Tanacross, Inc. If you have any questions or comments, feel free contact me at 202.720.1482 or Laura Dean 202.720.9634.

Thanks and Happy Holidays,

Lauren.

Lauren McGee, Environmental Scientist  
USDA, Rural Development Utilities Programs  
Mail Stop 1571, Rm 2239  
1400 Independence Ave, SW  
Washington, DC 20250  
202.720.1482 (phone)  
202.690.0649 (fax)  
[lauren.mcgee@wdc.usda.gov](mailto:lauren.mcgee@wdc.usda.gov)  
<http://www.usda.gov/rus/water/ees/environ.htm>

12/16/2009



United States Department of Agriculture  
Rural Development

DEC 24 2008

Ted Wellman  
Davis Wright Tremaine LLP  
Suite 800  
701 W. Eight Avenue  
Anchorage, Alaska 99501-3468

Re: Proposed Yerrick Creek Hydroelectric Project

On December 17, 2008, Alaska Power and Telephone Company (AP&T) provided the Rural Utilities Service (RUS) with a copy of your November 25, 2008 letter to Mr. Bruce A. Moore of DeLisio Moran Geraghty & Zobel, P.C., the legal representative for Tanacross, Inc. Be advised that RUS, the agency which administers the U.S. Department of Agriculture's Rural Development Utilities Programs, is responsible for the findings and determinations needed to complete the review process established under Section 106 of the National Historic Preservation Act and its implementing regulations (36 CFR Part 800). Accordingly, RUS is solely responsible for determining if Section 106 review is applicable to an undertaking and that undertaking's area of potential effect (APE). In this case, RUS has determined that the referenced proposal is an undertaking subject to Section 106 review and that lands held by Tanacross Inc. lie within the APE.

Furthermore, while RUS appreciates your observations on the matter, it is up to RUS working with the Alaska State Historic Preservation Office and other consulting parties to determine if historic properties are located in the referenced proposal's APE and how they might be affected. Accordingly, the statement in your November 25, 2008, letter stating that AP&T's consultant has made a determination of "no effect" is incorrect because such a determination is not within her authority to make. She may make a recommendation which RUS will consider. However, legally, the determination of effect must be made or endorsed by RUS.

Pursuant to 36 CFR Part 800, RUS is responsible for conducting consultation which is defined as "*seeking, discussing and considering the views of other participants, and, where feasible, seeking agreement with them regarding matters arising in the Section 106 process.*" RUS appreciates your opinions about the effect of the referenced proposal on historic properties and will consider this information in making its findings and determinations under 36 CFR §§ 800.4 and 800.5. As noted in our December 17, 2008 letter, RUS has made

no decisions because it is still consulting with the Villages of Tanacross, Tetlin and Dot Lake about properties to which these tribe might attach religious and cultural significance that might be affected by AP&T's proposal.

Finally, your November 25, 2008, letter asserts that the Alaska Power Company may decide to condemn an easement under AS 42.05.631 for use in the referenced proposal. Such an action, however, does not absolve RUS of its responsibilities under Section 106 and its implementing regulations as long as AP&T still has an application for financial assistance under consideration by the agency.

Should you have any questions or require additional information, please contact Laura Dean, Federal Preservation Officer, at 202-720-9634 or via email at [Laura.Dean@wdc.usda.gov](mailto:Laura.Dean@wdc.usda.gov).

Sincerely,



MARK S. PLANK

Director

Engineering and Environmental Staff  
Water and Environmental Programs

Enclosure(s):

Ted Wellman letter re: Yerrick Creek proposal

cc:

Robert Brean

Bruce Moore

Glen Martin

Villages of Tanacross, Tetlin and Dot Lake





## Davis Wright Tremaine LLP

ANCHORAGE BELLEVUE LOS ANGELES NEW YORK PORTLAND SAN FRANCISCO SEATTLE SHANGHAI WASHINGTON, D.C.

TED WELLMAN  
DIRECT (907) 257-5326  
tedwellman@dwt.com

SUITE 800  
701 W EIGHTH AVENUE  
ANCHORAGE, AK 99501-3468

TEL (907) 257-5300  
FAX (907) 257-5399  
WWW.DWT.COM

November 25, 2008

Bruce A. Moore  
DeLisio Moran Geraghty & Zobel, P.C.  
943 W. 6th Avenue  
Anchorage, Alaska 99501-2033

Re: Yerrick Creek Hydroelectric Proposal  
APC 2007RUS-01

Dear Mr. Moore:

Please be informed that this firm represents Alaska Power & Telephone Company ("AP&T") and its wholly-owned subsidiary Alaska Power Company ("APC") with regard to the development of the Yerrick Creek Hydroelectric Project, hereinafter referred to as the "Project." This letter is written in response to your letter of November 10, 2008, addressed to the Rural Development Electric Programs of the U.S. Department of Agriculture, Mr. Mark Plank. We are disappointed regarding the inaccurate assertions contained in your letter. Your letter ignores the good faith efforts AP&T and APC, hereinafter jointly "AP&T", have made to work with Tanacross, Inc. ("Tanacross") and mischaracterizes facts relevant to the consideration of this loan application.

A. The National Historic Preservation Act.

Your main argument in opposition to the Project is based on the unfounded assumption that the Tanacross land in question is subject to the National Historic Preservation Act of 1966 ("NHPA") purportedly because Tanacross selected the lands under the Alaska Native Claims Settlement Act. No such assumption is implied by law and there are no historic sites impacted by this Project that would invoke the provisions of the NHPA.

AP&T coordinated its research of potential historic sites with the State Historic Preservation Officer ("SHPO"), Judith E. Bittner as required by NHPA. The only potentially historic site near the route is an old cabin site on the west side of Yerrick Creek. The preferred location for the buried penstock is on the bluff above and



Bruce A. Moore  
November 20, 2008  
Page 2

approximately 500 feet from the cabin site along the creek. Further archeological work is scheduled for next year in coordination with the Alaska SHPO to determine the exact separation needed from the cabin to avoid the development requirements of NHPA. AP&T is committed to locating the buried penstock such that no conflict under NHPA will arise. AP&T's consultant Patricia Browne of Brown Research, Inc. has surveyed the other areas on both sides of the creek and determined that the project will have no effect on properties eligible for inclusion in the National Register of Historic Places. Accordingly, requirements identified in your letter that reference NHPA under Section 106 and the implementing regulations at 36 C.F.R. 800 are inapposite to this Project.

B. Impact of the Project on Tanacross.

Tanacross contends the Project will cause significant disruption in the use of Yerrick Creek by Tanacross. This contention ignores the minimal impact the Project will have on the land. Overall, the Project will occupy less than ten (10) acres of Tanacross land. The penstock consisting of a 36 inch to 48 inch pipe will be buried in an access road. The anticipated right-of-way for the penstock and access road will not normally exceed fifty (50) feet in width with the possible need to be slightly wider depending upon the terrain. The total length of the road and buried penstock on Tanacross land would be approximately one and one-half miles before the buried penstock will enter the powerhouse. The footprint for the powerhouse and associated switchyard would be approximately 80 feet by 80 feet near the existing highway. The exact location of the powerhouse has not been finalized and AP&T is committed to avoiding any conflicts with pipeline facilities which we understand are currently designed for the other side of the highway and a significant distance from the proposed powerhouse. If you have information that shows a conflict please advise.

None of these facilities would interfere with use of the area for the subsistence activities like hunting, berry picking and harvest of birch bark as discussed in your letter. Except during the construction stage, Tanacross shareholders would be free to engage in such subsistence activities throughout the Project area. Your letter mentions a trail across the area. AP&T is not aware of any such existing trail and assume you mean an easement for a trail. No aspect of the Project would interfere or disrupt the use of a trail, except briefly during construction<sup>1</sup>.

---

<sup>1</sup> We understand the Alaska Department of Fish & Game has asked that the access road not be opened for use by the public.

Bruce A. Moore  
November 20, 2008  
Page 3

C. AP&T's Efforts to Negotiate with Tanacross.

Your letter states that AP&T has not yet begun negotiations with Tanacross over the land in question. This ignores two years of diligent efforts by AP&T to work with and provide information to Tanacross about the project. Our records indicate that AP&T personnel met with Robert Brean many times between October 2006 and March 2008 in a futile effort to negotiate regarding the land in question. Mr. Brean stonewalled AP&T's efforts by often refusing to discuss the matter with AP&T and repeatedly refusing to allow AP&T to make a presentation to the Tanacross Board. AP&T has bent over backwards in attempting to negotiate this minimum intrusion on Tanacross property and can not be expected to do more.

D. AP&T's Project and the Gas Pipeline.

We are confused over the implication that the construction of the Project adversely affects the future construction of the Denali Alaska Pipeline. Nothing could be further from the truth. The Project neither occupies land needed for the pipeline nor interferes with pipeline construction. The opposite is true in that the additional electric energy provided by the Project will likely be needed for construction camps and other pipeline construction. In addition, the Project and pipeline construction are many years apart. The Project will likely be on line in two years. The gas pipeline is at least ten years away and there is no certainty that it will be constructed then. This is not an "either/or" situation. The construction of the gas pipeline is not dependent upon the demand for energy in the Tok area. Based on economies of scale, it is highly doubtful that gas will be used for generation of electric energy for the foreseeable future in the Tok area. Even if gas from the pipeline were used to generate power in the distant future, the current hydroelectric Project would still be needed. Please explain how building a hydroelectric project and lowering the cost of energy for all consumers in the Tok area is anything but positive.

Tanacross contends that AP&T is obligated to engage in the futile process of evaluating other sites and new technology such as placing a plant on the Tanana River. Since the Project does not affect any historic sites under NHPA, AP&T has no obligation to engage in an evaluation of frivolous alternatives. AP&T has considered the costs and benefits of new power projects to serve the Tok area such as development of a coal fired plant. While alternative projects may be developed in the future, the Project is a reasonable cost-effective way to reduce costly diesel generation now with an immediate benefit to customers throughout the Tok region. If you believe AP&T is obligated to further evaluate other alternatives to this clean hydroelectric project, please cite the statutory authority requiring such evaluations.

Bruce A. Moore  
November 20, 2008  
Page 4



E. Prior Commitments Made to Denali – The Alaska Gas Pipeline LLC.

Tanacross claims the Project conflicts with legal commitments already made to the Denali – The Alaska Gas Pipeline LLC ("Denali"). AP&T has not found any evidence of such commitments. If you have documentary evidence that Tanacross has made legal commitments to Denali, such as granting an easement or sale of property, please provide copies. Since no pump stations are currently scheduled for the powerhouse site, AP&T is confident it can coordinate its tiny footprint with Denali's land requirements, if any. If Denali does construct the gas pipeline in the future, AP&T will work cooperatively to resolve any conflicts which may develop.

F. APC's Rights as a Certificated Public Utility.

The real reason for your refusal to deal with AP&T regarding this matter may be the desire to become a power supplier by using gas from the pipeline, if and when the pipeline is constructed. That is not a justifiable reason for refusing to provide the minimal land necessary to AP&T to construct the Project. As you know, Tetlin, Dot Lake, and Tok have all signed endorsements for this Project which should significantly lower the costs of energy in the Tok area. In addition, construction of this project will add to the security and reliability of power in this area.

As I am sure you are aware, APC holds the certificate of public convenience and necessity to serve the Tok area issued by the Regulatory Commission of Alaska. As a certificated public utility, AP&T has the authority to condemn an easement under AS 42.05.631. The fact the land was conveyed under ANCSA does not shield Tanacross from such action. APC has been reluctant to exercise this authority and prefers to negotiate with Tanacross over the fair market value without the necessity of litigation. However, APC is not willing to stand idly by and see the Tok area denied the benefits of a small hydroelectric facility which will undeniably lower costs for no valid reason. AP&T can clearly demonstrate the benefits of this Project to the community sufficient to condemn the necessary right of way. We strongly suggest that you avoid this course of action by sitting down and negotiating in good faith with AP&T to resolve any adverse problems.

Very truly yours,

Davis Wright Tremaine LLP

Ted Wellman

cc: Robert Grimm

**Attachment 4**

2009 Cultural Resource Survey of Alaska Power & Telephone's Yerrick Creek  
Hydroelectric Project near MP 1334 of the Alaska Highway, Alaska (Nov. 2009) –

Completed by Northern Land Use Research, Inc.

C.D. format

**Office of History and Archaeology: Cultural Resources Report Coversheet**  
*(Must Accompany All Compliance Reports Submitted to OHA/SHPO)*



**Office of History and Archaeology**  
 Division of Parks & Outdoor Recreation  
 Alaska Department of Natural Resources  
 550 W. 7<sup>th</sup> Ave., Suite 1310  
 Anchorage, AK 99501-3565  
 Phone: (907) 269-8721 Fax (907) 269-8908  
 http://www.dnr.state.ak.us/parks/oha/index.htm

Was this survey/investigation (Check one):    Negative     Positive

Negative = no cultural resource sites are reported or updated. Positive = cultural resource sites are reported or updated.

Note: Alaska Heritage Resources Survey (AHRs) numbers are **required** for reported cultural resource sites, including buildings. AHRs numbers can be obtained by contacting Joan Dale at 907-269-8718).

**Project/Report Information:**

- Report Title:    2009 Cultural Resource Survey of Alaska Power & Telephone's Yerrick Creek Hydroelectric Project near MP 1334 of the Alaska Highway, Alaska
- Report Author(s): Molly Proue, M.A., R.P.A., and Burr Neely, M.A., R.P.A.
- Report Date:    November 2009
- Submitting Organization/Agency: Northern Land Use Research, Inc.
- Project Name and Project Number: 09-968 Yerrick Creek Hydroelectric Project
- Principal Investigator (PI) name: Peter M. Bowers, M.A., R.P.A.

**Geographic Information (attach an extra sheet or cite report page numbers if necessary)**

- USGS Mapsheet (1:63,360 if available)    Tanacross B-6
- Meridian/Township / Range / Section (MTRS) location: (all affected sections)  
 Format example: "F021N018E|13-14"    C019N009E, Section 36; C018N009E, Sections 1, 2, 11, and 14
- Verbal description of survey area \_\_\_\_\_  
 (for example: "123 Acme Street," "confluence of Fish and Moose creeks," "Milepost 9-16 ...")

**The middle portion of the Yerrick Creek drainage, south of the Alaska Highway, 22 miles west of Tok.**

- Does this report contain boundary coordinates for the surveyed area?    Yes     No     Page #(s) \_\_\_\_\_
- Does this report contain boundary coordinates for reported sites?    Yes     No     Page #(s) \_\_\_\_\_
- Land owner(s):    State of Alaska and Tanacross Native Corp.
- Answer one:                      Acres Surveyed 127                      Hectares Surveyed \_\_\_\_\_

**Cultural Resources Management (CRM) Information**

- List AHRs numbers of new and updated sites – (do not list sites that are merely described in the background section).  
TNX-211 and TNX-212

- Is the report part of a National Historic Preservation Act - Section 106 consultation?                      Yes     No
- Is the report part of an Alaska Historic Preservation Act compliance consultation?                      Yes     No
- Does the report's data support a submitting agency's determination of eligibility?                      Yes     No
- Does the report's data support a submitting agency's determination of effect?                      Yes     No
- Was this report submitted to fulfill State Field Archaeology Permit requirements?  
 Permit No.:    Permit Application # 2009-27                      Yes     No
- Was this project and/or report overseen or authored by someone meeting the minimum qualifications of the Sec. of the Interior's Standards and Guidelines (48 FR 44738-44739)?                      Yes     No
- Is the Principal Investigator's resume' appended to the report or on file at OHA?                      Yes     No

(BLANK PAGE)

# ALASKA POWER & TELEPHONE COMPANY

P.O. BOX 3222 • 193 OTTO STREET  
PORT TOWNSEND, WA 98368  
(360) 385-1733 • (800) 982-0136  
FAX (360) 385-5177

December 9, 2009

Valerie Baxter  
Natural Resource Specialist  
ADNR – HMLW Fairbanks  
3700 Airport Way  
Fairbanks, AK 99709-4699

Re: Land Use Permit Application – Yerrick Creek Permit Application LIS No. 27271

Dear Ms. Baxter:

Per a conversation I had with Jim Anderson earlier this year, enclosed are updated maps showing the location of the project, project site plan, and the right-of-way through Department of Natural Resources land. Mr. Anderson specifically asked us to indicate if the project would impact an existing trail on the east side of Yerrick Creek. The project features will be on the west side of the creek until approximately 2 miles upstream. The trail, on the opposite side of the creek, veers away from the creek within the first mile, eliminating any conflict.

We would appreciate DNR completing their project review, including any public noticing, to the point of either issuing a permit with a caveat that we need access through private land (Tanacross Inc.) or holding the permit that is ready to issue until we have the documentation of the access to private land, which will be submitted to DNR as soon as it is available. We currently have a habitat permit with ADF&G for construction and are presently applying for a Corp of Engineer permit.

Sincerely,

A handwritten signature in black ink that reads "Glen D. Martin". The signature is written in a cursive style with a long, sweeping underline.

Glen D. Martin  
Project Manager  
(360) 385-1733 x122

Enc. (as stated)



(BLANK PAGE)

# STATE OF ALASKA

DEPARTMENT OF NATURAL RESOURCES

**NORTHERN REGION LANDS OFFICE**

**SARAH PALIN, GOVERNOR**

NORTHERN REGION  
3700 AIRPORT WAY  
FAIRBANKS, ALASKA 99709-4699  
PHONE: (907) 451-3014  
FAX: (907) 451-2751  
[dianna.leinberger@alaska.gov](mailto:dianna.leinberger@alaska.gov)

August 12, 2009

Glen D. Martin  
Project Manager  
Alaska Power & Telephone Company  
Corporate Headquarters  
P.O. Box 3222  
Port Townsend, WA 98368  
(360) 385-1733 x122  
(360) 385-7538 fax

Mr. Martin,

This letter is to inform you that the Land Use Permit, LAS #27271, for geotechnical exploration in the Yerrick Creek drainage has been completed and is ready for signature. Please review the attached Memorandum of Decision (MOD) and the permit and listed stipulations. You will need to print out the permit, provide your information and signature where indicated, and then return only the signature page to me via email or by fax. I will then sign where indicated and issue the permit by sending you a scanned copy of the completed signature page. You will need to send me your original signed page by regular mail.

I realize APT wants to send the excavator up Yerrick Creek soon and the only requirement remaining is the Performance Guaranty. The signed permit will be valid as soon as we receive proof of the bond.

If you have questions about any of the enclosed information or stipulations, please feel free to contact me at (907) 451-2710 or at [valerie.baxter@alaska.gov](mailto:valerie.baxter@alaska.gov). Thank you.

Sincerely,



Valerie Baxter  
Natural Resource Specialist

**STATE OF ALASKA  
DEPARTMENT OF NATURAL RESOURCES  
DIVISION OF MINING, LAND AND WATER  
NORTHERN REGION**



Memorandum of Decision  
LAS 27271 – Yerrick Creek Geotechnical Exploration Access

**Proposed Action**

Glen Martin, on behalf of Alaska Power and Telephone Company (APT), submitted a land use permit application to drive an excavator through the Yerrick Creek drainage in order to conduct geotechnical exploration at a proposed hydroelectric project site. APT is requesting four days to travel from the Alaska Highway to the project site, conduct testing, and return. The excavator is a Robox 130 LCM-3 and the proposed route across state land would involve travel in the dry creek beds of Yerrick Creek and would require crossing the active channels of Yerrick Creek up to 6 times. The geotechnical exploration would involve the digging of 6 test pits, up to 20ft deep, to characterize the substrate. The test pits would be located a minimum of 50ft from the active channel and would be refilled with the excavated material upon completion.

The Department proposes to issue the permit as requested.

**Authority**

This permit is being adjudicated pursuant to Alaska Statute 38.05.850 (Permits).

**Administrative Record**

The administrative record for the proposed action consists of Alaska Administrative Code 11 AAC 96 (Miscellaneous Land Use); Tanana Basin Area Plan (TBAP, 1991 Update); LAS 27271, the current casefile, and this memorandum of decision.

**Location**

- Geographic:** The access point to Yerrick Creek is located at milepost 1333.6 of the Alaska Highway and is 88.4 miles east of Delta Junction. USGS Map Tanacross B-6 63K. See attachment A.
- Legal Description:** Copper River Meridian, Township 18 North, Range 9 East, Sections 11 and 14.
- Borough:** This area is within the Tanacross Inc., region and 3 sections of corporation land must be crossed before reaching state land. Permission to access and cross Tanacross Inc., lands was obtained on June 10, 2009, and permits from ADF&G Habitat division (FH09-III-0128) and the US Army Corps of Engineers (POA-2009-445) have also been received. The project is within an unorganized Borough, though it is not within a coastal zone.

**Title**

The State received tentative approval for Sections 11 and 14 under General Grant GS895 on 12/20/1963.

## **Classification**

This site is within the Tanana Basin Area Plan (TBAP, 1991 Update), Subregion 6, Upper Tanana, Management Unit 6C3, Buck Creek, and is classified wildlife habitat. This management unit has critical rated habitat for grizzly bear, moose, and sheep. The Tok River area of 6C3 has been identified in the TBAP as meriting legislative designation as a State Game Refuge because of outstanding wildlife and public values.

Forestry and recreation are listed as secondary surface uses within this unit and the unit is closed to land disposals and remote cabins. 6C3 is open to mineral entry. There is nothing in the TBAP which prohibits the proposed use.

## **Eligibility**

Alaska Power and Telephone Company is in good standing with the state of Alaska.

## **Courtesy Agency Notice**

Courtesy agency notice was sent via electronic mail to the following agencies:

Meg Hayes and Associates, Land Management Consultant for Tanacross, Inc.

Jim Vohden, Hydrologist, Water Section, DMLW, DNR

Robert McLean, Regional Manager, Division of Habitat, AK Department of Fish & Game

Alan Skinner, Regulatory Specialist, US Army Corp of Engineers, Anchorage, AK

Three agency comments were received: one from ADF&G acknowledging that a fish habitat permit had been issued; one from the USACE, acknowledging that a Nationwide Permit 6 authorization had been granted for this project; one from Tanacross, Inc., stating that they have granted permission to AP&T to access Tanacross lands for this project. No comments were received that objected to ADNR issuing this land use permit.

A Public Notice was issued on 07/15/2009 and the comment deadline was 07/31/2009. No public comments were received.

## **Background**

APT is pursuing a run-of-river hydroelectric project on Yerrick Creek and in 2007 they applied for a state land lease, ADL 418154. They are currently applying for a temporary land use permit to conduct substrate testing to determine permeability and the location of bedrock in order to choose the best placement of the hydroelectric diversion structure.

The first sections of the proposed route cross Tanacross, Inc, land and APT has acquired their permission for access. A wetlands delineation and jurisdictional determination were conducted and APT was authorized to conduct testing under a US Army Corps of Engineers Nationwide Permit No. 6 (POA-2009-445). Fish surveys in Yerrick Creek were also performed and APT has received authorization for instream equipment crossing and geotechnical exploration from ADF&G Habitat Division (FH09-III-0128).

No roads exist into the proposed testing area. Yerrick Creek is a cobble, gravel, and sand substrate creek which crosses the Alaska Highway at approximately milepost 1339. The project area is mostly undeveloped, with an open gravel waterway, old gravel side channels in various stages of succession, and forested banks. There is an existing ANCSA 17(b) easement trail that

runs roughly parallel to the creek, through the forest, on the west side. This trail's permitted uses, when adjacent to Tanacross lands, include only travel by foot, dogsleds, animals, snowmobiles, two- and three-wheeled vehicles, and small all-terrain vehicles. The trail is currently approximately 6 ft wide and is typically used by hunters to access the foothills to the south. Accessing the project site via this trail would involve vegetation clearing and disturbance of the vegetative mat and is not the least environmentally damaging alternative.

### Discussion

According to LAS and the APMA waypoint file there are no other land authorizations in this area.

In adjudicating a LUP permit, DNR seeks to facilitate development, conservation, and enhancement of state lands for present and future Alaskans, while minimizing disturbance to vegetative, hydrologic, and topographic characteristics of the area that may impair water quality and soil stability. This use will not adversely affect the State of Alaska's goals of conserving and enhancing natural resources for use by present and future Alaskans.

### Environmental Risk

Equipment storage and fueling operations would not occur within 50' of Yerrick Creek, a drainage or wetland. In order to minimize potential impacts to resident fish, the proposed timing of travel for the excavator is during the low water period of August/September 2009.

### Performance Guarantee and Insurance

As directed in 11 AAC 96.060 (Performance guaranty) the applicant shall furnish security acceptable to the department. Using the performance guarantee matrix, the recommended performance guaranty is \$4500.

### Permit Fees

As directed in 11 AAC 05.010(c)(5) there is no annual use fee for a land use permit that does not hinder other public use.

### Recommendation

Based upon the information provided by the applicant, as well as review of relevant planning documents, statutes, and regulations related to this application, it is the decision of the Alaska Department of Natural Resources, Division of Mining, Land and Water, to issue this land use permit on condition that all permit stipulations are followed as described in attached permit. The term of this permit is for the months of **August 13, 2009 through September 30, 2009**. During the period of the permit periodic inspections may be conducted at the discretion of DNR to ensure permit compliance.

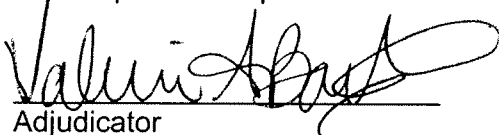
  
\_\_\_\_\_  
Adjudicator

8-12-2009  
\_\_\_\_\_  
Date

  
\_\_\_\_\_  
Review by Manager

8/12/09  
\_\_\_\_\_  
Date

## **Appeals**

A person affected by this decision may appeal it, in accordance with 11 AAC 02. Any appeal must be received by 09/15/2009, as defined in 11 AAC 02.040(c) and (d) and may be mailed or delivered to Tom Irwin, Commissioner, Department of Natural Resources, 550 W. 7th Avenue, Suite 1400, Anchorage, Alaska 99501; faxed to 1-907-269-8918, or sent by electronic mail to [dnr.appeals@alaska.gov](mailto:dnr.appeals@alaska.gov). This decision takes effect immediately. If no appeal is filed by the appeal deadline, this decision becomes a final administrative order and decision of the department on 09/30/2009. An eligible person must first appeal this decision in accordance with 11 AAC 02 before appealing this decision to Superior Court. A copy of 11 AAC 02 may be obtained from any regional information office of the Department of Natural Resources.



**STATE OF ALASKA**  
**Department of Natural Resources**  
**Division of Mining, Land & Water**

**LAND USE PERMIT**  
**Under AS 38.05.850**

**PERMIT # LAS 27271**

Alaska Power and Telephone Company, herein known as the permittee, is issued this permit authorizing the use of state land located within:

Copper River Meridian, Township 18 North, Range 9 East, Sections 11 and 14, as shown in Attachment A.

This permit is **effective beginning August 13<sup>th</sup>, 2009 and ending September 30<sup>th</sup>, 2009** unless sooner terminated at the State's discretion. This permit does not convey an interest in state land and as such is revocable with or without cause.

This permit is issued for the purpose of authorizing:

Travel of a Robox 130 LCM-3 excavator through the Yerrick Creek drainage. The proposed route across state land would involve travel in the dry creek beds of Yerrick Creek and would require crossing the active channels of Yerrick Creek up to 6 times. The geotechnical exploration would involve the digging of 6 test pits, up to 20ft deep, to characterize the substrate.

All activities shall be conducted in accordance with the following Permit Stipulations.

**Permit Stipulations**

- 1. Authorized Officer.** The Authorized Officer for the Department of Natural Resources is the Regional Land Manager or his designee. The Authorized Officer may be contacted at 3700 Airport Way, Fairbanks, Alaska 99709 or (907) 451-2740. The Authorized Officer reserves the right to modify these stipulations or use additional stipulations as deemed necessary.
- 2. Compliance with Governmental Requirements and Recovery of Costs.** Permittee shall, at its expense, comply with all applicable laws, regulations, rules and orders, and the requirements and stipulations included in this authorization. Permittee shall ensure compliance by its employees, agents, contractors, subcontractors, licensees, or invitees. This authorization is revocable immediately upon violation of any of its terms, conditions, and stipulations or upon failure to comply with any applicable laws, statutes and regulations (state and federal).
- 3. Performance Guaranty.** The permittee shall provide a surety bond or other form of security acceptable to the Division in the amount of \$ 4500.00 payable to the State of Alaska. Such performance guaranty shall remain in effect for the term of this authorization and shall secure performance of the permittee's obligations hereunder. The amount of the performance guaranty may be adjusted by the Authorized Officer upon approval of amendments to this authorization, changes in the development plan, upon any change in the activities conducted, or performance of operations conducted on the premises. If Permittee fails to perform the obligations under this permit within a reasonable amount of time, the State may perform Permittee's obligations at Permittee's expense. Permittee agrees to pay within 20 days following demand, all costs and expenses reasonably incurred by the State of Alaska as a result of the failure of the permittee to comply with the terms of this permit. The provisions of this permit shall not prejudice the State's right to obtain a remedy under any law or regulation. If the Authorized Officer determines that the permittee has satisfied the terms and conditions of this authorization the performance guaranty may be released. The performance guaranty may only be released in a writing signed by the Authorized Officer.

4. **Other Authorizations.** The issuance of this authorization does not alleviate the necessity of the permittee to obtain authorizations required by other agencies for this activity.
5. **Termination.** This permit does not convey an interest in state land and as such is revocable immediately, with or without cause.
6. **Public Access.** The permittee shall not close landing areas or trails. The ability of all users to use or access state land or public water must not be restricted in any manner.
7. **Public Trust Doctrine.** The Public Trust Doctrine guarantees public access to, and the public right to use navigable and public waters and the land beneath them for navigation, commerce, fishing and other purposes. This authorization is issued subject to the principles of the Public Trust Doctrine regarding navigable or public waters. The Division of Mining, Land and Water (Division) reserves the right to grant other interests consistent with the Public Trust Doctrine.
8. **Valid Existing Rights.** This authorization is subject to all valid existing rights in and to the land covered under this authorization. The State of Alaska makes no representations or warranties, whatsoever, either expressed or implied, as to the existence, number or nature of such valid existing rights.
9. **Reservation of Rights.** The Division reserves the right to grant additional authorizations to third parties for compatible uses on or adjacent to the land covered under this authorization. Authorized concurrent users of state land, their agents, employees, contractors, subcontractors and licensees shall not interfere with the operation or maintenance activities of authorized users.
10. **Preference Right.** No preference right for long term use or conveyance of the land is granted or implied by the issuance of this authorization.
11. **Assignment.** This permit may not be transferred or assigned to another individual or corporation.
12. **Site Maintenance.** The area subject to this authorization shall be maintained in a neat, clean, and safe condition, free of any solid waste, debris, or litter.
13. **Site Disturbance.**
  - (a) Site disturbance shall be kept to a minimum to protect local habitats. All activities at the site shall be conducted in a manner that will minimize the disturbance of soil and vegetation and changes in the character of natural drainage systems.
14. **Site Restoration.**
  - (a) Upon expiration, completion, or termination of this authorization, the site shall be vacated and all improvements, personal property, and other chattels shall be removed or they will become the property of the state.
  - (b) The site shall be left in a clean, safe condition acceptable to the Authorized Officer. All solid waste debris and any hazardous wastes that are used and stored on the site shall be removed and backhauled to an ADEC approved solid waste facility.
15. **Fire Prevention, Protection and Liability.** The permittee shall take all reasonable precautions to prevent and suppress forest, brush and grass fires, and shall assume full liability for any damage to state land resulting from negligent use of fire. The State of Alaska is not liable for damage to the permittee's personal property and is not responsible for forest fire protection of the permittee's activity.
16. **Holes and Excavations.** All holes shall be backfilled with sand, gravel, or native materials.
17. **Destruction of Markers.** All survey monuments, witness corners, reference monuments, mining claim posts, bearing trees, and unsurveyed lease corner posts shall be protected against damage, destruction, or obliteration. The permittee shall notify the Authorized Officer of any damaged, destroyed, or obliterated



markers and shall reestablish the markers at the permittee's expense in accordance with accepted survey practices of the Division of Land.

18. **Hazardous Substances.** The use and/or storage of hazardous substances by the permittee must be done in accordance with existing federal, state and local laws, regulations and ordinances. Debris (such as soil) contaminated with used motor oil, solvents, or other chemicals may be classified as a hazardous substance and must be removed and disposed of in accordance with existing federal, state and local laws, regulations and ordinances.
19. **Spill Notification.** The permittee shall immediately notify the Alaska Department of Environmental Conservation (ADEC) by telephone, and immediately afterwards send ADEC a written notice by facsimile, hand delivery, or first class mail, informing ADEC of: any unauthorized discharges of oil to water, any discharge of hazardous substances other than oil; and any discharge or cumulative discharge of oil greater than 55 gallons solely to land and outside an impermeable containment area. If a discharge, including a cumulative discharge, of oil is greater than 10 gallons but less than 55 gallons, or a discharge of oil greater than 55 gallons is made to an impermeable secondary containment area, the permittee shall report the discharge within 48 hours, and immediately afterwards send ADEC a written notice by facsimile, hand delivery, or first class mail. Any discharge of oil, including a cumulative discharge, solely to land greater than one gallon up to 10 gallons must be reported in writing on a monthly basis. The posting of information requirements of 18 AAC75.305 shall be met. Scope and Duration of Initial Response Actions (18 AAC 75.310) and reporting requirements of 18 AAC 75, Article 3 also apply.

The permittee shall supply ADEC with all follow-up incident reports. Notification of a discharge must be made to the nearest DEC Area Response Team during working hours: Anchorage (907) 269-7500, fax (907) 269-7648; Fairbanks (907) 451-2121, fax (907) 451-2362; Juneau (907) 465-5340, fax (907) 465-2237. The DEC oil spill report number outside normal business hours is (800) 478-9300.

20. **Operation of Vehicles.**
- (a) Crossing waterway courses will be made using an existing low angle approach in order to not disrupt the naturally occurring stream or lake banks.
  - (b) There shall be no bank modification.
  - (c) Wherever possible, watercourses shall be crossed at shallow riffle areas from point bar to point bar.
  - (d) During equipment maintenance operations and overnight storage, the site shall be protected from leaking or dripping hazardous substances or fuel. The permittee shall place drip pans or other surface liners designed to catch and hold fluids under the equipment or develop a maintenance area by using an impermeable liner or other suitable containment mechanism.
21. **Alaska Historic Preservation Act.** The Alaska Historic Preservation Act (AS 41.35.200) prohibits the appropriation, excavation, removal, injury, or destruction of any state-owned historic, prehistoric (paleontological) or archaeological site without a permit from the commissioner. Should any sites be discovered during the course of field operations, activities that may damage the site will cease and the Office of History and Archaeology, Division of Parks and Outdoor Recreation, (907) 269-8721, shall be notified immediately.
22. **Inspections.** Authorized representatives of the State of Alaska shall have reasonable access to the subject parcel for purposes of inspection. The permittee may be charged fees under 11 AAC 05.010(a)(7)(M) for routine inspections of the subject parcel, inspections concerning non-compliance, and a final closeout inspection.
23. **Indemnification.** Permittee assumes all responsibility, risk, and liability for its activities and those of its employees, agents, contractors, subcontractors, licensees, or invitees, directly or indirectly related to this permit, including environmental and hazardous substance risk and liability, whether accruing during or after the term of this permit. Permittee shall defend, indemnify, and hold harmless the State of Alaska, its agents and employees, from and against any and all suits, claims, actions, losses, costs, penalties, and damages of whatever kind or nature, including all attorney's fees and litigation costs, arising out of, in connection with, or incident to any act or omission by Permittee, its employees, agents, contractors, subcontractors,

licensees, or invitees, unless the proximate cause of the injury or damage is the sole negligence or willful misconduct of the State or a person acting on the State's behalf. Within 15 days, Permittee shall accept any such cause, action or proceeding upon tender by the State. This indemnification shall survive the termination of the permit.

24. **Violations.** This authorization is revocable immediately upon violation of any of its terms, conditions, stipulations, nonpayment of fees, or upon failure to comply with any other applicable laws, statutes and regulations (federal and state). Should any unlawful discharge, leakage, spillage, emission, or pollution of any type occur due to permittee's, or its employees', agents', contractors', subcontractors', licensees', or invitees' act or omission, permittee, at its expense shall be obligated to clean the area to the reasonable satisfaction of the State of Alaska.
25. **Change of Address.** Any change of address must be submitted in writing to the office of responsibility.
26. **Permit Amendments.** Permittee proposals requiring the amendment of this permit must be in submitted in writing.
27. **Completion Report.** A completion report shall be submitted within 30 days of the termination of the authorized activities. The report shall contain the following information:
  - (a) A statement of restoration activities and methods of debris disposal.
  - (b) Photographs of the permitted site taken before, during, and after the proposed activity to document permit compliance. Photos must consist of a series of aerial or ground level view photos that clearly depict compliance with site cleanup and restoration guidelines.

**Advisory Regarding Violations of the Permit Guidelines.** Pursuant to 11 AAC 96.145, a person who violates a provision of a permit issued under this chapter (11 AAC 96) is subject to any action available to the department for enforcement and remedies, including revocation of the permit, civil action for forcible entry and detainer, ejectment, trespass, damages, and associated costs, or arrest and prosecution for criminal trespass in the second degree. The department may seek damages available under a civil action, including restoration damages, compensatory damages, and treble damages under AS 09.45.730 or 09.45.735 for violations involving injuring or removing trees or shrubs, gathering geotechnical data, or taking mineral resources.

If a person responsible for an unremedied violation of 11 AAC 96 or a provision of a permit issued under this chapter (11 AAC 96) applies for a new authorization from the department under AS 38.05.035 or 38.05.850, the department may require the applicant to remedy the violation as a condition of the new authorization, or to begin remediation and provide security under 11 AAC 96.060 to complete the remediation before receiving the new authorization. If a person who applies for a new authorization under AS 38.05.035 or 38.05.850 has previously been responsible for a violation of this chapter or a provision of a permit issued under this chapter, whether remedied or unremedied, that resulted in substantial damage to the environment or to the public, the department will consider that violation in determining the amount of the security to be furnished under 11 AAC 96.060 and may require the applicant to furnish three times the security that would otherwise be required.

The Authorized Officer reserves the right to modify these stipulations or use additional stipulations as deemed necessary. The permittee will be advised before any such modifications or additions are finalized. Any correspondence on this permit may be directed to the Department of Natural Resources, Division of Mining, Land and Water, Northern Region Office, 3700 Airport Way, Fairbanks, Alaska 99709-4699 telephone (907) 451-2740.

I have read and understand all of the foregoing and attached stipulations. By signing this permit, I agree to

conduct the authorized activity in accordance with the terms and conditions of this permit.

Glen D. Martin Project Manager 8-12-09  
Permittee Title Date

PO Box 3222, Port Townsend, WA 98368 360-385-1733 x122 Glen  
Address Phone Contact Name

Valerie A. Burt NRS II 8-12-2009  
Signature of Authorized State Representative Title Date

-143° 45' -143° 44' -143° 43' -143° 42' -143° 41' -143° 40' -143° 39' -143° 38' -143° 37' -143° 36' -143° 35' -143° 34' -143° 33' -143° 32'

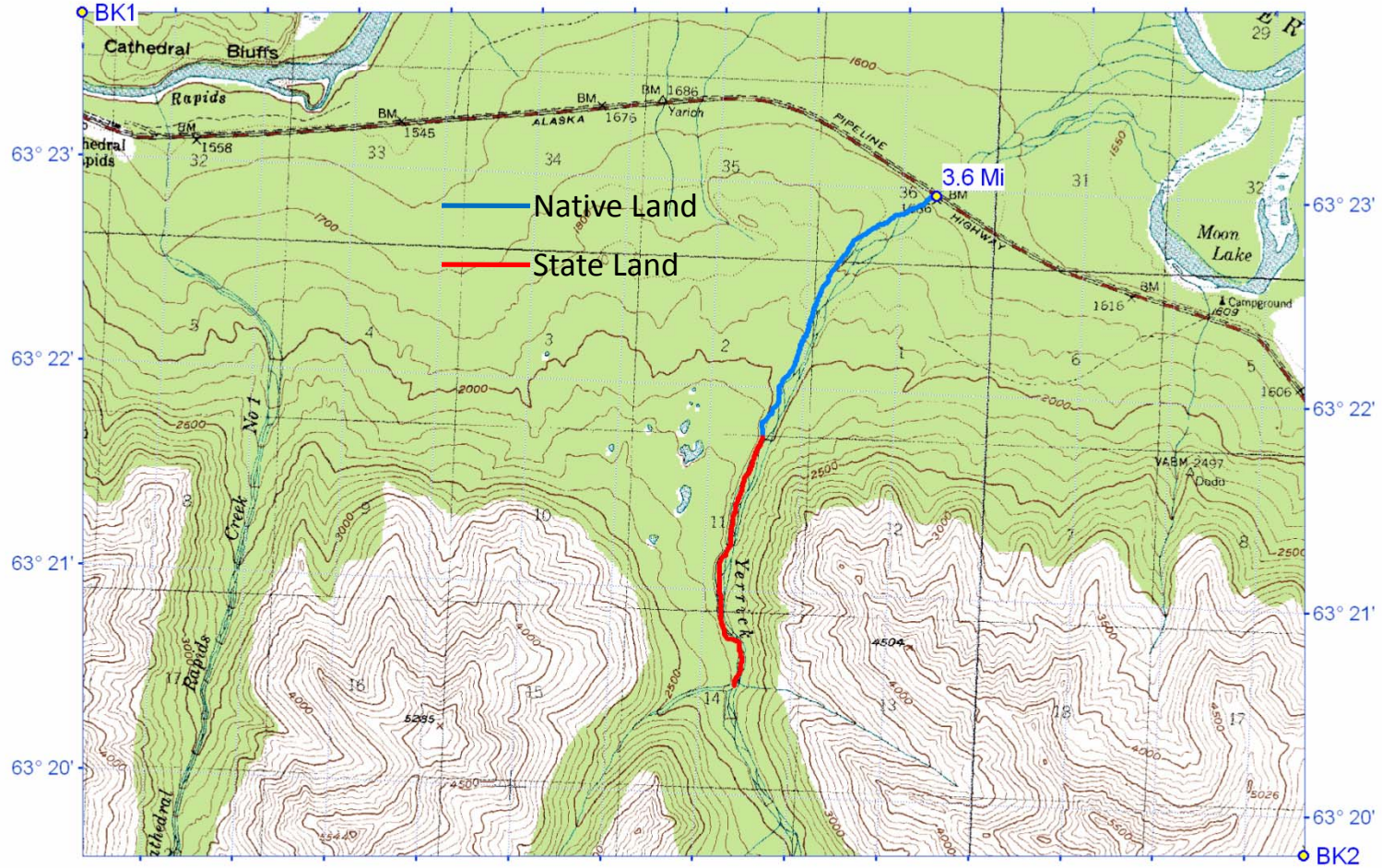

-143° 45' -143° 44' -143° 43' -143° 42' -143° 41' -143° 40' -143° 39' -143° 38' -143° 37' -143° 36' -143° 35' -143° 34' -143° 33' -143° 32'

1983 North American Datum; UTM grid zone 7  
Generated by BigTopo7 (www.igage.com)  
Map compiled from USGS Quads  
Tanacross B-6 63K; AK

UTM Grid and 2009 Magnetic North  
Declination at Center of Sheet  
GN to TN 2.357° (42 miles)  
TN to MN 25.297° (450 miles)

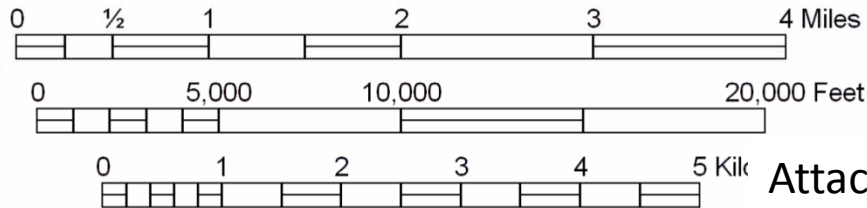

Attachment A: APT Yerrick Creek Access Map

(BLANK PAGE)

# STATE OF ALASKA

## DEPARTMENT OF FISH AND GAME

### DIVISION OF HABITAT

**SEAN PARNELL, GOVERNOR**

1300 COLLEGE ROAD  
FAIRBANKS, AK 99701-1551  
PHONE: (907) 459-7289  
FAX: (907) 459-7303

## **FISH HABITAT PERMIT FH09-III-0182**

ISSUED: August 5, 2009  
EXPIRES: December 31, 2012

Mr. Glen Martin  
Project Manager  
Alaska Power and Telephone Company  
P.O. Box 3222  
Port Townsend, WA 98368

RE: Yerrick Creek Hydroelectric Stream Diversion and Water Impoundment

Pursuant to AS 16.05.841, the Alaska Department of Fish and Game (ADF&G), Division of Habitat has reviewed your proposal to construct an impoundment dam and bypass up to 60 cfs of water through a 48-inch diameter, 15,000 feet long penstock, with bypassed flows reentering Yerrick Creek after passing through a hydro power house located near the Alaska Highway. Civil design for construction of the diversion or bypass of excess water around the diversion were not provided.

Yerrick Creek support resident fish species (e.g., Arctic grayling, Dolly Varden) in the area of your proposed activity. The resident Dolly Varden population is located in the headwaters and middle bypass reach. Arctic grayling are predominately in the lower reach below the diversion reentry point, but also have been documented in the middle bypassed reach.

Based upon our review of your plans, your proposed project may obstruct the efficient passage and movement of fish. In accordance with AS 16.05.841, project approval is hereby given subject to the following stipulations:

1. Prior to construction, civil plans for construction of the impoundment dam and excess flow bypass shall be submitted to ADF&G for review and approval.

2. The excess flow bypass shall be constructed as a roughened channel (see enclosed example) that permits all flow in excess of 60 cfs to remain in the middle bypass reach and that provides fish passage, both upstream and downstream.
3. Prior to construction, plans shall be submitted to provide for fish exclusion at the penstock intake. These plans must provide for an effective screen opening that does not exceed  $\frac{1}{4}$  inch.

The permittee is responsible for the actions of contractors, agents, or other persons who perform work to accomplish the approved plan. For any activity that significantly deviates from the approved plan, the permittee shall notify the Division of Habitat and obtain written approval in the form of a permit amendment before beginning the activity. Any action taken by the permittee, or an agent of the permittee, that increases the project's overall scope or that negates, alters, or minimizes the intent or effectiveness of any stipulation contained in this permit will be deemed a significant deviation from the approved plan. The final determination as to the significance of any deviation and the need for a permit amendment is the responsibility of the Division of Habitat. Therefore, it is recommended that the Division of Habitat be consulted immediately when a deviation from the approved plan is being considered.

**This letter constitutes a permit issued under the authority of AS 16.05.841 and must be retained on site during the permitted activity.** Please be advised that this approval does not relieve you of the responsibility of securing other permits, state, federal or local.

This permit provides reasonable notice from the Commissioner that failure to meet its terms and conditions constitutes violation of AS 16.05.861; no separate notice under AS 16.05.861 is required before citation for violation of AS 16.05.841 can occur. In addition to the penalties provided by law, this permit may be terminated or revoked for failure to comply with its provisions or failure to comply with applicable statutes and regulations. The Division of Habitat reserves the right to require mitigation measures to correct disruption to fish and game created by the project and which was a direct result of the failure to comply with this permit or any applicable law.

The recipient of this permit (permittee) shall indemnify, save harmless, and defend the Division of Habitat, its agents and its employees from any and all claims, actions or liabilities for injuries or damages sustained by any person or property arising directly or indirectly from permitted activities or the permittee's performance under this permit. However, this provision has no effect, if, and only if, the sole proximate cause of the injury is the Division of Habitat negligence.

Please be advised that this determination applies only to activities regulated by the Division of Habitat; other departments and agencies also may have jurisdiction under their respective authorities. This determination does not relieve you of the responsibility for securing other permits, state, federal, or local. You are still required to comply with all other applicable laws.

Sincerely,

Denby S. Lloyd, Commissioner

A handwritten signature in black ink, appearing to read "Robert F. McLean". The signature is written in a cursive style with a large, stylized initial "R".

BY: Robert F. "Mac" McLean, Regional Supervisor  
Division of Habitat

ecc: Chris Milles, ADNR, Fairbanks  
Larry Bright, USFWS, Fairbanks  
NOAA Fisheries, Anchorage  
Al Ott, ADF&G, Fairbanks  
Fronty Parker, ADF&G, Delta  
Tom Taube, ADF&G, Fairbanks  
Jeff Gross, ADF&G, Tok

RFM/mac



## Roughened-Channel Design

The most important aspects to consider in the design of roughened channels are:

- bed stability,
- average velocity at flows up to the fish-passage design flow,
- turbulence, and
- bed porosity.

Maximum average velocity and turbulence are the basic criteria of the Hydraulic Design Option. The bed materials inside the culvert create resistance to flow. Their stability is fundamental to the permanence of that structure. The effect of turbulence on fish passage can be approximated by limiting the energy-dissipation factor (EDF). In order for low flows to remain on the surface of the culvert bed and not percolate through a coarse, permeable substrate, bed porosity must be minimized. (Each of these considerations are discussed in subsequent sections of this chapter.)

The following is an outline of a suggested procedure for designing roughened channels. These steps are iterative; several trials may have to be calculated to determine a final acceptable design. (Additional details of these steps are provided in subsequent sections.)

1. Assume a culvert span. Begin with a culvert bed width equal to the stream width. Habitat considerations should be included at this phase in the design process. In particular, debris and sediment transport and the passage of nontarget fish and wildlife should be considered, all of which benefit from increased structure width.
2. Size the bed material for stability on the basis of unit discharge for the 100-year event ( $Q_{100}$ ), as outlined in Step 3.
3. Check to see that the largest bed-particle size, as determined by stability, is less than one quarter the culvert span. If not, increase the culvert width, which decreases the unit discharge and, in turn, the particle size.
4. Create a bed-material gradation to control porosity (see Chapter 6).
5. Calculate the average velocity and EDF at the fish-passage design flow on the basis of culvert width and the bed  $D_{84}$  from gradation in Step 4 above. If the velocity or EDF exceed the criteria, increase the culvert span.

6. Check the culvert capacity for extreme flood events. This step is not detailed here, but it is required, just as it is for any new culvert or retrofit culvert design that affects the culvert's capacity.

The width of the culvert bed should be at least the width of the natural stream channel as defined in this guideline. When the width of the bed in roughened channel culverts is less than the bed width of the stream, hydraulic conditions are more extreme and the channel inside the culvert is more likely to scour. As gradient and unit discharge increase, the best way to achieve stability and passability is to increase the culvert width.

## Bed Stability

In order for the roughened channel to be reliable as a fish-passage facility, it is essential that the bed material remain in the channel more or less as placed. It is expected that the bed material will shift slightly but not move any appreciable distance or leave the culvert. Bed stability is essential because these channels are not alluvial. Since they are often steeper and more confined than the natural, upstream channel, recruitment of larger material cannot be expected. Any channel-bed elements lost will not be replaced, and the entire channel will degrade. The 100-year flood is suggested as a high structural-design flow.

Bed-stability considerations, rather than fish-passage velocities, usually dominate the design of the bed-material composition. It is, therefore, recommended that bed-stability analysis be performed before calculating the fish-passage velocity.

At this time, there are no procedures that can determine the specific size of bed material needed to meet the angle of slope and volume of discharge for steep, roughened channels. In the case of the stream-simulation design option we can use natural analogs or models of natural systems to reliably estimate bed-material size (see Chapter 6). Roughened channels, on the other hand, increase hydraulic forces due to constriction and increased slope. Unfortunately we do not have a factor to relate the two and must resort to other methods. Four general methods are reviewed here:

- the U.S. Army Corps of Engineers steep slope nprap design,
- the critical-shear-stress method,
- the U.S. Army Corps of Engineers flood-control-channel method, and
- empirical methods.

## U.S. Army Corps of Engineers Riprap Design

U.S. Army Corps of Engineers reference, EM 1110-2-1601, Section e., steep slope riprap design, gives this equation (Equation 1) for cases where slopes range from two to 20 percent, and unit discharge is low.

$$D_{30} = \frac{1.95S^{0.555}(1.25q)^{2/3}}{g^{1/3}}$$

### Equation 1

Where:  $D_{30}$  = the dimension of the intermediate axis of the 30th percentile particle  
 $S$  = the bed slope  
 $q$  = the unit discharge  
 $g$  = acceleration due to gravity.

The recommended value of 1.25 as a safety factor may be increased. The study from which this equation was derived cautions against using it for rock sizes greater than 6 inches.<sup>1</sup> The equation predicts sizes reasonably in hypothetical situations above this, but it has not been tested in real applications.

The U.S. Army Corps of Engineers recommends angular rock with a uniform gradation ( $D_{85}/D_{15} = 2$ ). This material is not preferred for use in a fish-passage structure (see the section on bed porosity, below). An approximate factor to scale  $D_{30}$  of a uniform riprap gradation for one that is appropriate for stream channels is 1.5, so that,

$$D_{84} = 1.5D_{30}$$

### Equation 2

Where:  $D_{84}$  = the dimension of the intermediate axis of the 84th percentile particle.

## Critical-Shear-Stress Method

Critical shear stress is a time-honored method to estimate the initial movement of particles. J. C. Bathurst<sup>2</sup> and D. S. Olsen, et. al.,<sup>3</sup> among others, have said that critical shear stress should not be applied to steep channel, although R. A. Mussetter,<sup>4</sup> and R. Wittler and S. Abt<sup>5</sup> and others have used it. The Federal Highway Administration, developed a channel-lining design method based on critical shear stress, with data from flume and field studies.<sup>6</sup> The data is largely from low-gradient situations, but the design charts show slopes up to 10 percent and particle sizes up to 1.9 feet, which places it in the range of designed roughened channels.

The condition of stability is defined as the point at which the critical shear stress,  $\tau_c$ , equals the maximum shear stress,  $\tau_{(max)}$ , experienced by the channel.

The critical shear stress is the shear stress required to cause the movement of a particle of a given size and is equal to four times  $D_{50}$ , where  $D_{50}$  is the 50<sup>th</sup> percentile particle, in feet. This relationship implies a critical, dimensionless shear stress of about 0.039. Mussetter<sup>4</sup> and Wittler and Abt<sup>5</sup> used 0.047. J. M. Buffington and D. R. Montgomery<sup>7</sup> discuss the range of  $\tau_c$ . The maximum shear stress is 1.5 times  $\gamma RS$ , where  $\gamma$  is the unit weight of water,  $R$  the hydraulic radius and  $S$  the slope.

## U.S. Army Corps of Engineers Flood-Control-Channel Method

U.S. Army Corps of Engineers EM 1110-2-1601 hydraulic design of flood-control channels manual uses a modified shear-stress approach to riprap design. This method should not be applied to channels greater than two-percent gradient. S. T. Maynard<sup>8</sup> modified this method for steep slopes:

$$D_{30} = C' (q^{2/3} S^{0.432}) / (g^{1/3} KI)$$

### Equation 3

$$C' = 5.3(S_f C_v C_t C_s)^{0.785} \left( \frac{\gamma_w}{\gamma_s - \gamma_s} \right)$$

### Equation 4

$$KI = \text{Cos}\alpha (1 - (\gamma_w / (\gamma_s - \gamma_w)) \text{Tan}\alpha / \text{Tan}\phi)$$

### Equation 5

Where:  $\alpha$  = the angle of the channel bottom from horizontal  
 $\phi$  is the angle of repose of the riprap.

Other constants as described in the Corps manual. Note the similarity to Equation 1 above. This method should only be applied by those familiar with EM 1110-2-1601.

## Empirical Methods

There are a number of velocity methods based on empirical studies: U.S. Bureau of Reclamation (USBR EM-25),<sup>9</sup> U.S. Geological Survey,<sup>10</sup> S. V. Isbash<sup>11</sup> and the American Society of Civil Engineers.<sup>12</sup> They have in common this basic equation (Equation 6), with some modifications, where  $a$  and  $K$  are constants derived from field studies.

$$D_{30} = V^a / (K(\gamma_s - \gamma))$$

Equation 6

These methods are questionable for the design of roughened channel beds. Theoretically, the problem is that stream slope is not explicitly a factor in the analysis, and the velocity distribution is quite different at high bed slopes than it is in the low-gradient channels for which these methods were developed. Gravitational forces increase with slope, decreasing stability of a given rock size. Roughness increases with slope,<sup>13</sup> which reduces velocity, and, in turn the recommended rock size.

**Figure E-1** compares various predictions of bed-material size as a function of slope. The sediment size is  $D_{84}$  for all the methods (except the Federal Highway Administration method<sup>6</sup> and the Isbash method,<sup>11</sup> which are riprap sizing techniques giving  $D_{50}$  of a uniform riprap gradation). The other significant variable – discharge – is held constant at 10 cfs/ft. This is a typical, bed-forming flow intensity for high-gradient channels. With increasing unit discharge, Isbash predicts smaller particle sizes at higher slopes relative to the other methods, and the Federal Highway Administration predicts much larger sizes.

Figure E-1. Relative performance of various sediment stability equations (Unit discharge = 10 cfs/ft)

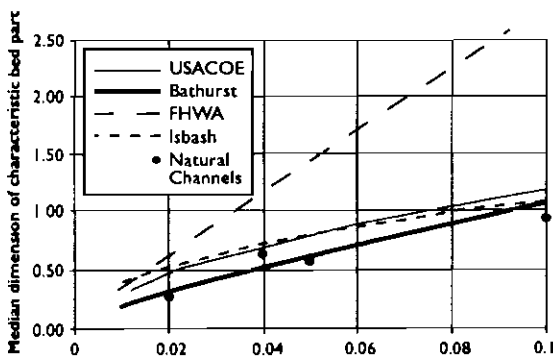

Various predictions of bed-material size as a function of slope.

Four natural streams are also shown in **Figure E-1** for reference. These streams' bed-changing discharge is estimated to be, on average, 9.4 cfs/ft.  $D_{84}$  from the actual bed-material distribution is shown here.

Shear stress is directly proportional to slope so the Federal Highway Administration method (critical shear stress) shows a linear relationship with slope. This is a trend not reflected in the other methods or the natural beds. Although, what is not accounted for in this simple analysis is that only a portion of the total boundary shear stress is responsible for sediment transport. Momentum losses due to hydraulic roughness other than bed friction account for the rest.<sup>14</sup> In addition, velocity profiles of steep, rough channels are not the same as hydraulically smooth, lower-gradient channels where shear-stress analysis was developed.<sup>15</sup> High-gradient channels have velocity profiles that are nonlogarithmic, unlike low-gradient channels.

The Isbash method is based solely on velocity, which is relatively insensitive to slope. Velocity, in this case, was developed from the J. T. Limerinos<sup>16</sup> roughness equation averaged with J. Costa's<sup>17</sup> power law for velocity, using the Bathurst<sup>2</sup> estimate of bed material size.

It is interesting to note that all the riprap-sizing techniques converge when slope is roughly one percent, which is the slope considered the upper limit of shear stress and velocity-based analysis.

Bathurst is consistent with natural streambed material that is expected to move at this flow intensity and is recommended for the design of stream simulation culverts. This should be the lower limit of particle sizes for designing roughened channels. The safety factor, which separates Bathurst from the actual design requirement, should be based on the various design factors.

As the width of the roughened channel culvert decreases relative to the width of the channel, flow intensity increases, and inlet contraction plays a role in stability. The bed-material design techniques account for increases in intensity, but they do not include inlet contraction as a factor. Small increases in head loss at the inlet can result in changes in velocity large enough to significantly change bed-material size estimates. A head loss of 0.1 foot represents an approximate 1.8 feet/sec velocity increase ( $h = KV^2/2g$ ,  $K = 0.5$ ) at the inlet, possibly forcing supercritical flow (see next paragraph). If Isbash is used, a 50-percent increase in rock size may be required. Equivalent flow intensity (the increase in unit discharge required to represent the head loss) increases dramatically as inlet losses occur.

The movement of bed material in natural, steep channels is thought to coincide with supercritical flow.<sup>18</sup> If, by decreasing the width of a culvert, the Froude number is caused to approach 1.0 at flows below those used to size the particles, then it is likely that the bed may fail prematurely. Unfortunately, most of the roughness-factor models were specifically developed for subcritical flow; it is, as a result, difficult to determine how flow velocity approaches supercritical flow. K. J. Tinkler<sup>19</sup> used an approach that calculates a specific Manning's  $n$  for the critical case, as a function of slope and depth. The Limerinos equation<sup>16</sup> (shown below in the section on velocity) follows this closely when it is determined that the bed roughness approximates a natural channel.

In cases where inlet contraction is minimal and flow inside the culvert is not expected to go supercritical prematurely, it is recommended that the U.S. Army Corps of Engineers' equation for steep channels be used to size bed material for roughened channels. This recommendation is made even though the equation was not considered applicable for particles over six inches in diameter. It still gives results in line with what we might expect to find in steep channels.

In addition to the methods mentioned here, theoretical work has been done by a number of researchers on the initial movement and general bedload discharge in steep, rough natural channels. Citations are shown in the references section at the end of this appendix.<sup>1,2,18,21,22,23</sup>

It is not recommended that culverts with bed material inside be designed to operate in a pressurized condition under any predicted flow. The riprap design methods suggested here assume open channel flow. They were not developed for high velocity and turbulence under pressure. Under most scenarios, it is assumed that minimum width requirements and fish-passage velocity criteria will be the limiting factors in design, not high flow capacity. But there may be cases where an unusual combination of events creates a situation where headwater depth exceeds the crown of the culvert. In such a case a conservative stability analysis would model the culvert using a complete culvert analysis program and/or a backwater model. The hydraulic results could then be used to estimate shear stress conditions and determine a stable rock size.

## Fish-Passage Velocity

The point of roughening the channel is to create an average cross-sectional velocity within the limits of the fish-passage criteria and the Hydraulic Design Option. The average velocity of a roughened channel culvert is essentially a function of

- stream flow,
- culvert bed width, and
- bed roughness.

The flow used to determine the fish-passage velocity is the fish-passage design flow as described in the section, Hydrology in Chapter 5, *Hydraulic Design Option*. As a design starting point, the width of the culvert bed should be at least the width of the natural stream-channel bed.

Steep and rough conditions present a unique challenge for hydraulic modeling. Traditional approaches to modeling open-channel flow assume normal flow over a bed having low relative roughness. In roughened channels, the height of the larger bed materials are comparable with the flow depth and complex turbulence dominates the flow.<sup>21</sup> A number of equations are available for an analysis of these conditions, but they are crude and generate widely varying results. Research to date has centered on estimating flow in natural, cobble/boulder streams and is not intended for use in engineering artificial channels.

Three researchers have used bed-material characterization and/or channel geometry to create empirical equations predicting roughness: Jarrett,<sup>13</sup> Limerinos<sup>16</sup> and Mussetter.<sup>4</sup> Generally, the conclusion one can draw from these studies is that friction factors in steep, rough channels are much larger than those found in lower-gradient streams. This conclusion is not surprising but it is notable just how high the roughness factors are. For instance, in Mussetter's field data on steep channels, 75 percent of the Manning's  $n$  values exceed 0.075, the highest  $n$  featured in H. H. Barnes' *Roughness Characteristics of Natural Channels*,<sup>24</sup> which covers larger, lower-gradient streams. It remains unclear as to how natural channels compare to constructed, roughened channels.

## **AQP** Case Studies

### **Janes Creek**

#### Roughened Channel over Small Dam

#### **Case Study Contributors**

- Antonio Llanos, Michael Love & Associates
- Michael Love, Michael Love & Associates

#### **Location**

South Fork Janes Creek, Humboldt Bay Watershed, Northern California, USA. [MAP](#)

#### **Project Type**

- Roughened Channel over Dam
- Prefabricated Bridge

#### **Pre-project Conditions**

- 4 ft (1.2 m) tall dam, historically used for water supply
- Concrete box spillway with access road across dam crest
- Stored sediment created marshy wetland habitat ideal for rearing coho salmon

#### **Pre-project Barrier**

- 4 ft (1.2 m) drop over spillway plunging into shallow pool
- Barrier to all coho salmon, steelhead and cutthroat trout

#### **Watershed Characteristics**

- Drainage Area: 0.74 mi<sup>2</sup> (1.9 km<sup>2</sup>)
- Peak Design Flow (100-yr): 290 cfs (8.2 cms)
- Bankfull Flow (1.5-yr): 65 cfs (1.8 cms)
- High Passage Flow for:
  - Salmon and steelhead (1% exceedance flow): 15.9 cfs (0.45 cms)
  - Cutthroat trout (5% exceedance flow): 6.3 cfs (0.18 cms)
  - Juvenile salmonids (10% exceedance flow): 3.7 cfs (0.10 cms)

#### **Ecological Value**

Provide upstream and downstream passage for all native aquatic organisms. Open access to 5,000 ft (1,524 m) of salmonid spawning and rearing habitat upstream of dam, including 2,360 ft (719 m) of low gradient marshy habitat for rearing coho salmon.

#### **Project Design**

- Roughened channel: 100 ft (30.5 m) at 5% slope with 10 ft (3.0 m) long horizontal

transition aprons at each end

- Roughened channel bed material designed to be stable up to 100-year flow
- Active channel base-width = 7 ft (2.1 m)
- Bankfull width = 12 ft (3.7 m)
- 9 channel spanning rock structures placed flush with finished grade
- Installation of prefabricated bridge with 40 ft (12.2 m) span over roughened channel

#### **Challenges and Lessons Learned**

- Project to provide fish passage while preserving wetland formed by stored sediments behind dam
- Lack of construction oversight resulted in a wider and steeper channel than designed
- Donated rock too large for constructed channel banks, leading to excessive voids

#### **Project Contributors**

- Humboldt Fish Action Council
- Michael Love and Associates
- Winzler & Kelly Consulting Engineers
- Kernan Construction
- Green Diamond Resource Company

#### **Project Funding**

California Dept. of Fish and Game

#### **Completion Date**

October 2005

#### **Total Project Cost**

\$77,442

### **Project Summary**

The 4 ft (1.2 m) high water diversion dam built in the 1950's blocked upstream movement for all fish. Over time, the reservoir filled with fine sediment, forming an impounded high-value wetland. The stream flowed over the dam's spillway, which consisted of a concrete box culvert. The spillway created a 4 ft (1.2 m) drop into a shallow plunge pool.

The project objective was to preserve the upstream impounded wetland for juvenile rearing habitat while providing fish passage over the dam. The preferred alternative involved removal of the concrete spillway and construction of a roughened rock channel designed to (1) maintain the existing upstream grade, (2) avoid release of stored sediments, and (3) provide upstream and downstream passage for all native fish and other aquatic organisms.

The roughened channel is 100 ft (30.5 m) long, with an average slope of 5%. The shape and features of the roughened channel are intended to create a hydraulic environment

similar to a natural channel of similar slope. Since the upstream channel material is mostly fine grain sands and silts, the larger rock in a roughened channel will not be replenished if it is transported downstream. Therefore, the D84 sized rock used in the roughened channel was designed to be stable up to the 100-year design flow. Because the dam crest also serves as an access road, a 40 ft (12.1 m) long prefabricated steel bridge was placed over the roughened channel at the location of the removed spillway.

### Channel Design

Design of the roughened channel involved a bed stability analysis to determine the minimum rock size necessary to maintain a stable channel bed during the 100-year peak flow of 290 cfs (8.2 cms). The fish passage analysis examined water depth, velocity and turbulence during fish migration flows. By design, a roughened channel provides a wide distribution of water velocities, with many areas of slower water.

This analysis required an iterative process involving the interdependent variables of particle size, particle stability, channel roughness, and channel geometry. Two methods were used: the Unit-Discharge Bed Equation as defined by Bathurst (1978) for incipient motion of the  $D_{84}$  particle, (84% of the particles have a smaller diameter than the  $D_{84}$ ) and the US Army Corps of Engineers Steep Slope Riprap Design for the  $D_{30}$  particle (ACOE, 1994 in WDFW, 2003). A particle distribution was then developed following methods outlined in (WDFW, 2003) for the *Engineered Streambed Material* within the channel.

Rock Size	730 mm	290 mm	120 mm	36 mm	< 2 mm
Percent Finer	100	84	50	16	7

Using a maximum roughened channel slope of 5% as a "rule-of-thumb", the final design converged on an active channel base width of 7 ft (2.1 m), bankfull width of 12 ft (3.7 m), and bankfull depth of about 2 ft (0.6 m). To concentrate low flows, ensure adequate water depth for adult fish, and provide slower edge-water for smaller fish, the channel bottom includes a side slope of 10% towards the center. The banks were constructed of large rock to create a rigid and confined channel, characteristic of steep stream channels.

A series of rock structures constructed of 2 layers of 1 ton rock were built across the channel and backfilled with the Engineered Streambed Material. Rock structures were designed as rigid bed controls and to create small drops and complex flow patterns. The top of the rock structures were placed flush with the finished channel grade and maximum spacing between structures was limited to 20 ft (6 m). By design, higher streamflows were expected to move and sort the smaller rock, exposing the larger rock and create an intricate series of small steps, pools, and flow constrictions. This complex hydraulic environment creates suitable migration pathways for fish over a wide flow range, similar to those found in a naturally steep channel reach.

### Lessons Learned

In general, construction of a roughened channel requires skilled equipment operators, a large quantity of imported rock and aggregate, and on-site construction guidance from persons familiar with this type of design. Due to a lack of thorough construction oversight, the upper section of the channel was built with a width far wider than designed. Additionally, the slope of the upper channel section was less than designed, requiring steepening the channel slope under the bridge to approximately 8%. These deviations from the design have the potential to create insufficient depth at lower migration flows, possibly hindering fish passage.

The rock used to construct the channel banks was donated to the project, and larger than called for in the design. This resulted in large voids within the bank rock that should have been chinked with smaller material to prevent water from flowing behind the rocks and scouring the native material.

The horizontal transition apron constructed at the downstream end appears to be functioning well. The transition effectively dissipates energy and has prevented scour of the downstream natural channel.

Two years after construction the channel appears to be stable and functioning properly.

### References

Bathurst, J.C. 1978. *Flow Resistance of Large-Scale Roughness*. Journal of the Hydraulics Division, AM. Soc. Civil Engr., Vol. 104, No. HY12, pp. 1587-1603.

Washington Department of Fish and Wildlife Environmental Engineering Division. 2003. *Fish passage design at road culverts: a design manual for fish passage at road crossings*. May 2003. <http://www.wdfw.wa.gov/hab/engineer/cm/>.

**Published 04/04/07**



(BLANK PAGE)

Law Offices

VIA FACSIMILE 257-5399

June 10, 2009

Joseph M. Moran  
Michael C. Geraghty  
Patricia L. Zobel  
Bruce A. Moore  
Danielle M. Ryman  
Adolf V. Zeman  
Nora G. Barlow  
Stephanie M. Shanklin

Stephen S. DeLisio, *Of Counsel*

Ted Wellman, Esq.  
Davis Wright Tremaine, LLP  
701 W. 8th Avenue, Suite 800  
Anchorage, Alaska 99501

**Re: *Yerrick Creek – 2009 Permit***

Dear Mr. Wellman:

The letter responds to the recent communications between AP&T and Tanacross Incorporated (“Tanacross”) regarding AP&T’s permit status for the Yerrick Creek hydor-electirc project for year 2009. Tanacross is agreeable to granting AP&T a permit based on the information and representations AP&T provided in its February 18, 2009. That letter is attached hereto as “Exhibit 1” and incorporated by reference. It stands as a letter of understanding on the agreed upon terms for this permit except to the extent this letter modifies those terms, in which case the terms of this letter permit control.

The term of this permit begins June 10 and ends December 31, 2009.

By accepting as described below, AP&T is permitted to conduct the following activities on Tanacross property during the summer and fall of 2009.

1. staking of structure locations and alignments,
2. seismic refraction surveys,
3. excavate test pits,
4. test soil anchors,
5. fish surveys, and
6. archeological survey.

The extent that these activities are permitted as outlined in Exhibit 1, this permit is limited to those stated activities and subject to the following terms and conditions:

1. AP&T's activities on Tanacross land are limited to the area represented in the map attachments to Exhibit 1.
2. AP&T will use the riverbed for transportation whenever possible and avoid any unnecessary use or clearing of the present 25 foot wide trail easement. The uses permitted on this easement by the ANCSA 17(b) easement regulations are as follows: travel by foot, dogsleds, animals, snowmobiles, two- and three-wheeled vehicles, and small all-terrain vehicles (less than 3,000 lbs. gross vehicle weight). No expansion of these uses is allowed by this permit. No permanent road construction is allowed by this permit.
3. AP&T will reclaim the land to its natural state at the request of Tanacross after termination or expiration of the term of this permit.
4. AP&T will remove all trash, equipment, or other debris on Tanacross lands resulting from its access or improvements under this permit, whether AP&T or trespassers deposit such trash, equipment, or debris.
5. AP&T will not allow any of its employees to use alcohol or guns on Tanacross lands, or to hunt, fish or trap on Tanacross lands.
6. AP&T will protect against trespass as outlined in Section D of Exhibit 1.
7. AP&T will abide by all terms and conditions of all state, federal and local laws, regulations and permits related to the Yerrick Creek project when on Tanacross lands.
8. Data collected, compiled or obtained by AP&T regarding Tanacross lands is considered confidential information by Tanacross. AP&T will protect its confidentiality and will use any raw and analyzed data, maps, reports, and the like for internal purposes only. AP&T will identify and provide Tanacross with copies of all raw and analyzed data, maps, reports and similar materials regarding the Yerrick Creek project.

Ted Wellman, Esq.  
June 10, 2009  
Page 3 of 4

9. AP&T shall indemnify, save harmless, and defend Tanacross, its agents and its employees from any and all claims, actions or liabilities for injuries or damages sustained by any person or property arising directly or indirectly from permitted activities or AP&T's performance under this permit. However, this provision has no effect, if and only if, the sole proximate cause of the injury is Tanacross' negligence.
10. The affirmative duties and obligations of AP&T in this letter permit and Exhibit 1, including but not limited to those identified in numbers 3, 4, 8 and 9 above, shall survive the expiration or any termination of this letter permit.

This permit is granted with your assurance that AP&T will work closely with Tanacross and keep Tanacross informed of its activities on the subject land. Accordingly, Tanacross expects AP&T will continue to update and supplement the information, such as detailed methodology, use of subcontractors, etc., provided in Exhibit 1 as such information becomes available. AP&T will request permission before it undertakes any activities that deviate from the activities identified in this letter permit. AP&T should not assume that any activity that deviates from the approved plan is permitted unless Tanacross provides written approval.

If the terms and conditions of this Permit are acceptable to AP&T, please remit payment in the amount of **\$5,000** to Tanacross Incorporated, sign and return this letter (keeping a copy of for your records) and provide the name(s) of any individual(s) to whom Tanacross should communicate with respect to this Permit and AP&T's activities. You may deliver these to my office if that is convenient.

Thank you for your attention.

Very truly yours,

DeLISIO MORAN GERAGHTY & ZOBEL, P.C.

By:



Bruce A. Moore

Attachment as stated

Ted Wellman, Esq.  
June 10, 2009  
Page 4 of 4

APPROVED AND ACCEPTED:

By: \_\_\_\_\_  
Print name: \_\_\_\_\_

Date: \_\_\_\_\_

Communications on behalf of Tanacross to AP&T should be sent to:

\_\_\_\_\_  
Name  
\_\_\_\_\_

Telephone / Email:  
\_\_\_\_\_  
\_\_\_\_\_

Address:  
\_\_\_\_\_  
\_\_\_\_\_  
\_\_\_\_\_

# Davis Wright Tremaine LLP



ANCHORAGE BELLEVUE LOS ANGELES NEW YORK PORTLAND SAN FRANCISCO SEATTLE SHANGHAI WASHINGTON, D.C.

TED WELLMAN  
DIRECT (907) 257-5326  
tedwellman@dwt.com

SUITE 800  
701 W EIGHTH AVENUE  
ANCHORAGE, AK 99501-3468

TEL (907) 257-5300  
FAX (907) 257-5399  
www.dwt.com

February 18, 2009

Bruce A. Moore  
DeLisio Moran Geraghty & Zobel, PC  
943 W. 6th Avenue  
Anchorage, Alaska 99501

**RECEIVED -**

FEB 19 2009

Re: Permit Application -- Yerrick Creek

**DeLISIO MORAN  
GERAGHTY & ZOBEL, P.C.**

Dear Mr. Moore:

This letter responds to your letter of February 6, 2009, requesting additional information regarding Alaska Power & Telephone Company's ("AP&T") proposed activities on Tanacross property for the summer of 2009. Please appreciate that some of the detailed information requested is not yet available. For example, AP&T has not yet identified all the contractors that will perform the work described below. However, AP&T will provide that information to Tanacross as soon as it becomes available.

Please find attached as Exhibit A the latest plan and right-of-way drawings reflecting location of the power plant and other elements of proposed layout. Please understand this is the best currently available information. However, upon completion of the field work described below, minor adjustments may be necessary to reflect field conditions. AP&T commits to work closely with Tanacross to keep it informed of changes necessitated by field conditions.

## **A. Detailed Scheduled of the Activities Anticipated in 2009.**

- 1. Staking of structure locations and alignments:** This activity will commence as soon as snow conditions allow, likely in late April or early May.
- 2. Seismic refraction surveys:** This work is tentatively scheduled for June.
- 3. Test pits:** Depending upon ground conditions, we expect to dig the test pits in June.
- 4. Test soil anchors:** We would expect to test soil anchors at the same time test pits are being dug in June.



5. **Fish surveys:** We anticipate conducting the fish surveys during three time periods, mid-May, late June, and October.
6. **Archaeological survey:** The archaeological survey will follow staking of structures and alignments in June.
7. **Road construction:** Road construction would commence after receipt of all necessary Tanacross, state, and federal permits. We assume that construction would start in September at the earliest.

**B. Detailed Methodology for Carrying Out Each Activity Proposed for 2009.**

1. **Staking of structure locations and alignments:** The corners of the proposed powerhouse and the centerline of the access road will be located and staked using either conventional land surveying techniques (*i.e.*, total stations and prisms) or GPS techniques. Stakes will be wood with colored flagging. Access road staking will be at 100' intervals on straight sections and 25' or 50' intervals on curves. Sight lines between stake locations will be cleared of brush; no trees greater than 2" diameter will be cut.
2. **Seismic refraction surveys:** These surveys are to determine depth from the ground surface to subsurface strata, such as the water table, permafrost, or bedrock. Surveys may be necessary in the powerhouse area and potential permafrost areas to supplement those made in the diversion area in 2008. The work requires a three foot wide cleared path along the lines, which are generally 200' – 400' long. Small explosive charges are set off near the lines, and vibrations are recorded by a string of sensitive geophones set at regular intervals along the lines.
3. **Test pits:** We expect the ground at most of the project structures to be a mix of sand, gravel, and cobbles. To confirm this expectation and to obtain information about the size gradation, we will use an excavator to dig a pit at various locations to a depth of 10-15 feet. A geologist will inspect the walls of the pit, and a portion of the excavated material will be collected for laboratory testing. The pits will be filled in with the excavated material once the inspection is complete. On Tanacross lands, we would expect one test pit at the powerhouse and one near where the proposed access road crosses the old pipeline right-of-way if that location can be accessed by existing trails.
4. **Test soil anchors:** We are considering the use of soil anchors to reinforce steep cut slopes in the upper portion of the access road, off



Tanacross land. However, we would like to test whether the soil anchors can be installed in the cobbly ground, and the best place to do that would be at an exposed bank on Tanacross land on the west side of Yerrick Creek about 2,500 feet upstream of the highway bridge. The soil anchors would be installed by an attachment on the boom of an excavator, which would access the site by crawling up the west channel of Yerrick Creek, which is dry except during flood periods. As many as a dozen anchors of varying types and lengths would be installed and tested for pull-out strength.

5. **Fish surveys:** Fish biologists will walk the length of the proposed bypassed reach of Yerrick Creek to assess the habitat. Fish presence and usage of the habitat will be determined by setting minnow traps and/or electroshocking.
  6. **Archaeological survey:** An archaeologist approved by the state will walk through the proposed areas of impact to determine if artifacts are present.
  7. **Road construction:** If the necessary Tanacross, state, and federal permits can be obtained in time, AP&T will begin access road construction, beginning at the powerhouse area. The right of way proposed to be cleared for the road construction is 75 feet in width.
- C. **Identification and description of any heavy equipment intended to be used on Tanacross lands.** The test pits and test soil anchors will require use of a 200-size excavator. If road construction is authorized, heavy equipment will primarily be two 200 to 400-size excavators, two dump trucks, a road grader, and a screen plant.
- D. **Information for any subcontractors you intend to use in 2009.**
1. **Staking of structure locations and alignments:** This subcontractor is yet to be selected.
  2. **Seismic refraction surveys:** This subcontractor is yet to be selected.
  3. **Test pits:** This subcontractor is yet to be selected.
  4. **Test soil anchors:** This subcontractor is yet to be selected.
  5. **Fish surveys:** GRAYSTAR Pacific Seafood, Ltd.
  6. **Archaeological survey:** Northern Land Use Research, Inc.





7. **Road Construction:** This subcontractor is yet to be selected.

D. **Specific courses of Action AP&T will take to minimize non-intended third-party access and trespass.** All of the proposed work except road construction should not significantly increase non-intended third-party access and trespass; therefore no particular plan should be necessary. However, if road construction is authorized in 2009, AP&T will install a gate or gates on the road at suitable locations to prevent non-intended access.

AP&T will work closely to inform Tanacross of any trespass by third-parties to aid in the enforcement of keeping the area secure. AP&T has previously experienced problems in similar situations with shareholders demanding access to shareholder land. Since AP&T cannot verify the identity of shareholders or their rights to access, AP&T proposes to inform Tanacross promptly of any trespass problems. AP&T remains open to any practical way in which this coordination can be implemented to prevent unwanted access.

E. **Proposed ingress and egress for the reconnaissance and research activities.** Except for the test soil anchors and road construction, all ingress and egress on Tanacross lands will be by foot or by ATV on existing trails. The soil anchor test site will be accessed by the dry west branch of Yerrick Creek. If a road construction is authorized, then the constructed road will be used for ingress and egress.

F. **Insurance coverage for the proposed activities.** A copy of the insurance coverage is attached as Exhibit B.

G. **Identification of person(s) who will be responsible for reporting to Tanacross Inc. regarding activities on Tanacross lands.** AP&T's on-site manager with responsibility for coordinating with Tanacross will be identified prior to field work commencing. If another representative is appointed, AP&T will timely notify Tanacross. At present, Robert Grimm will be the party with whom Tanacross can coordinate.

H. **Map(s), including LIDAR products, that accurately depict intended areas of use.** Please see attached Exhibit A reflecting the best current information regarding anticipated property use.

I. **A budget for the project in 2009.** While an actual budget for 2009 depends upon weather, the contractors selected, yet to be discovered field conditions, and timing of the approvals and financing, AP&T currently expects to spend between \$120,000 and \$350,000 on this project in 2009.

Bruce A. Moore  
February 18, 2009  
Page 5



Hopefully this letter should answer, to the best of our current information, the questions posed in your letter of February 6, 2009. As I am sure you can appreciate, AP&T cannot commit to particular subcontractors until it is assured of being able to proceed. Likewise, the schedules proposed depend in part upon field conditions and how early spring arrives in the area. As schedules become more certain and subcontractors are identified, AP&T will notify Tanacross. Please advise if you need additional information and we will try to promptly respond. Thanks for your consideration.

Very truly yours,

Davis Wright Tremaine LLP

A handwritten signature in black ink, appearing to read 'Ted Wellman', written over a horizontal line.

Ted Wellman

TW:mkg

Encl.

cc: Robert Grimm

12484632v1 14871-135

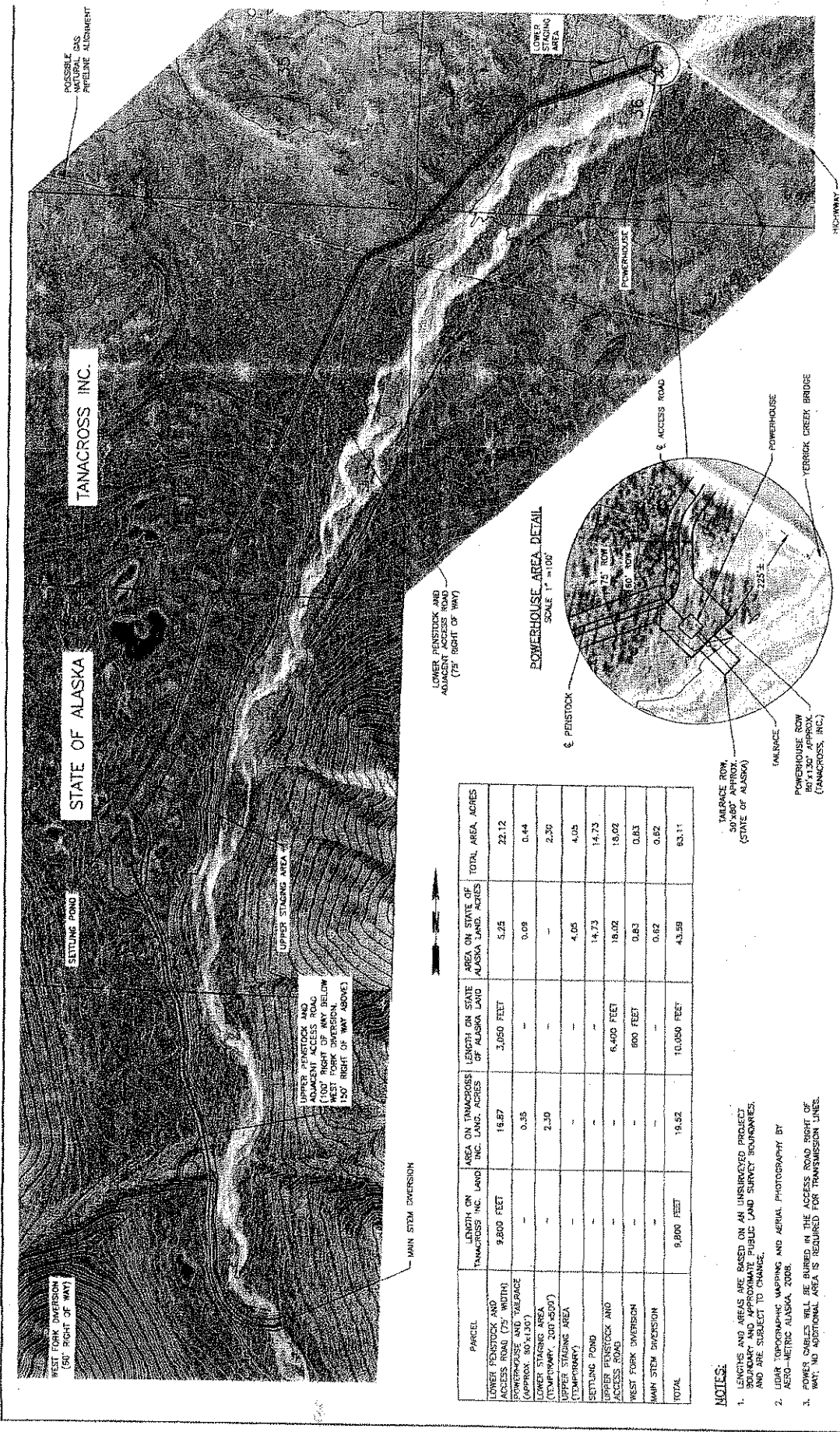

PARCEL	LENGTH ON TANACROSS INC. LAND	AREA ON TANACROSS INC. LAND	LENGTH ON STATE OF ALASKA LAND	AREA ON STATE OF ALASKA LAND	TOTAL AREA, ACRES
LOWER PENSTOCK AND ACCESS ROAD (75' WIDTH) (APPROX 90' TAILRACE ROW)	9,800 FEET	19.87	3,050 FEET	5.25	22.12
LOWER STAGING POND (TEMPORARY, 200'-600') (TEMPORARY)	-	0.35	-	0.09	0.44
SETTLING POND	-	2.30	-	-	2.30
UPPER PENSTOCK AND ACCESS ROAD	-	-	6,400 FEET	14.73	14.73
WEST FORK DIVERSION	-	-	800 FEET	0.83	0.83
MAIN STEM DIVERSION	-	-	-	0.62	0.62
TOTAL	9,800 FEET	19.52	10,050 FEET	43.59	63.11

NOTES:  
 1. LENGTHS AND AREAS ARE BASED ON AN UNRECTIFIED PROJECT BOUNDARY AND APPROXIMATE PLUG AND SURVEY BOUNDARIES, AND ARE SUBJECT TO CHANGE.  
 2. USGS TOPOGRAPHIC MAPPING AND AERIAL PHOTOGRAPHY BY ASG-METRIC ALASKA, 2008.  
 3. POWER CABLES WILL BE BURIED IN THE ACCESS ROAD RIGHT OF WAY; NO ADDITIONAL AREA IS REQUIRED FOR TRANSMISSION LINES.

**AP&T**  
ALASKA POWER & TELEPHONE COMPANY

YERRICK CREEK HYDROELECTRIC PROJECT  
GENERAL PLAN AND RIGHT OF WAY

DATE: 2-9-07  
 PROJECT NAME:  
 SHEET NUMBER:

SCALE: 1" = 600'  
 0 100 200 300 FT  
 1" = 200'

SCALE: 1" = 100'  
 0 100 200 300 FT  
 1" = 100'

NO.	DATE	DESCRIPTION	BY	CHK	APP	CHECKED:

EXHIBIT A  
 page 1 of 1

Client#: 1

POWE

# ACORD CERTIFICATE OF LIABILITY INSURANCE

DATE (MM/DD/YYYY)  
02/02/09

**PRODUCER**  
Parker Smith & Feek, Inc.  
Bellevue (425-709-3600)  
2233 112th Avenue NE  
Bellevue, WA 98004

**INSURED**  
ALASKA POWER & TELEPHONE COMPANY  
& SUBSIDIARIES  
P.O. BOX 3222  
Port Townsend, WA 98368

THIS CERTIFICATE IS ISSUED AS A MATTER OF INFORMATION ONLY AND CONFERS NO RIGHTS UPON THE CERTIFICATE HOLDER. THIS CERTIFICATE DOES NOT AMEND, EXTEND OR ALTER THE COVERAGE AFFORDED BY THE POLICIES BELOW.

INSURERS AFFORDING COVERAGE	NAIC #
INSURER A: Liberty Mutual Fire InsCo	23035
INSURER B: Liberty Mutual Ins Co	23043
INSURER C:	
INSURER D:	
INSURER E:	

**COVERAGES**

THE POLICIES OF INSURANCE LISTED BELOW HAVE BEEN ISSUED TO THE INSURED NAMED ABOVE FOR THE POLICY PERIOD INDICATED. NOTWITHSTANDING ANY REQUIREMENT, TERM OR CONDITION OF ANY CONTRACT OR OTHER DOCUMENT WITH RESPECT TO WHICH THIS CERTIFICATE MAY BE ISSUED OR MAY PERTAIN, THE INSURANCE AFFORDED BY THE POLICIES DESCRIBED HEREIN IS SUBJECT TO ALL THE TERMS, EXCLUSIONS AND CONDITIONS OF SUCH POLICIES. AGGREGATE LIMITS SHOWN MAY HAVE BEEN REDUCED BY PAID CLAIMS.

INSR ADD'L LTR	INSR	TYPE OF INSURANCE	POLICY NUMBER	POLICY EFFECTIVE DATE (MM/DD/YY)	POLICY EXPIRATION DATE (MM/DD/YY)	LIMITS	
A		<b>GENERAL LIABILITY</b> <input checked="" type="checkbox"/> COMMERCIAL GENERAL LIABILITY <input type="checkbox"/> CLAIMS MADE <input checked="" type="checkbox"/> OCCUR  GEN'L AGGREGATE LIMIT APPLIES PER: <input type="checkbox"/> POLICY <input checked="" type="checkbox"/> PROJECT <input checked="" type="checkbox"/> LOC	TB2-641438688028	11/01/08	11/01/09	EACH OCCURRENCE	\$1,000,000
						DAMAGE TO RENTED PREMISES (Ea occurrence)	\$500,000
						MED EXP (Any one person)	\$5,000
						PERSONAL & ADV INJURY	\$1,000,000
						GENERAL AGGREGATE	\$10,000,000
						PRODUCTS - COMP/OP AGG	\$2,000,000
A		<b>AUTOMOBILE LIABILITY</b> <input checked="" type="checkbox"/> ANY AUTO <input type="checkbox"/> ALL OWNED AUTOS <input type="checkbox"/> SCHEDULED AUTOS <input checked="" type="checkbox"/> HIRED AUTOS <input checked="" type="checkbox"/> NON-OWNED AUTOS	AS2-641438688018	11/01/08	11/01/09	COMBINED SINGLE LIMIT (Ea accident)	\$1,000,000
						BODILY INJURY (Per person)	\$
						BODILY INJURY (Per accident)	\$
						PROPERTY DAMAGE (Per accident)	\$
		<b>GARAGE LIABILITY</b> <input type="checkbox"/> ANY AUTO				AUTO ONLY - EA ACCIDENT	\$
						OTHER THAN AUTO ONLY: EA ACC	\$
						AGG	\$
		<b>EXCESS/UMBRELLA LIABILITY</b> <input type="checkbox"/> OCCUR <input type="checkbox"/> CLAIMS MADE  DEDUCTIBLE RETENTION \$				EACH OCCURRENCE	\$
						AGGREGATE	\$
							\$
							\$
B		<b>WORKERS COMPENSATION AND EMPLOYERS' LIABILITY</b> ANY PROPRIETOR/PARTNER/EXECUTIVE OFFICER/MEMBER EXCLUDED? If yes, describe under SPECIAL PROVISIONS below OTHER	WC1-641438688038	11/01/08	11/01/09	<input checked="" type="checkbox"/> WC STATU-TORY LIMITS <input type="checkbox"/> OTH-ER	
						E.L. EACH ACCIDENT	\$1,000,000
						E.L. DISEASE - EA EMPLOYEE	\$1,000,000
						E.L. DISEASE - POLICY LIMIT	\$1,000,000

DESCRIPTION OF OPERATIONS / LOCATIONS / VEHICLES / EXCLUSIONS ADDED BY ENDORSEMENT / SPECIAL PROVISIONS

\*Workers Comp Information: Maritime; USLH; Other States Coverage  
Exhibit of Insurance. Application ID: 19867

**CERTIFICATE HOLDER**

DOT  
Utilities Section  
2301 Peger Road  
Fairbanks, AK 99709

**CANCELLATION**

SHOULD ANY OF THE ABOVE DESCRIBED POLICIES BE CANCELLED BEFORE THE EXPIRATION DATE THEREOF, THE ISSUING INSURER WILL ENDEAVOR TO MAIL 0 DAYS WRITTEN NOTICE TO THE CERTIFICATE HOLDER NAMED TO THE LEFT, BUT FAILURE TO DO SO SHALL IMPOSE NO OBLIGATION OR LIABILITY OF ANY KIND UPON THE INSURER, ITS AGENTS OR REPRESENTATIVES.

AUTHORIZED REPRESENTATIVE  
*[Signature]*

EXHIBIT B  
page 1 of 2

## IMPORTANT

If the certificate holder is an ADDITIONAL INSURED, the policy(ies) must be endorsed. A statement on this certificate does not confer rights to the certificate holder in lieu of such endorsement(s).

If SUBROGATION IS WAIVED, subject to the terms and conditions of the policy, certain policies may require an endorsement. A statement on this certificate does not confer rights to the certificate holder in lieu of such endorsement(s).

## DISCLAIMER

The Certificate of Insurance on the reverse side of this form does not constitute a contract between the issuing insurer(s), authorized representative or producer, and the certificate holder, nor does it affirmatively or negatively amend, extend or alter the coverage afforded by the policies listed thereon.

EXHIBIT B  
Page 2 of 2

(BLANK PAGE)



REPLY TO  
ATTENTION OF:

**DEPARTMENT OF THE ARMY  
U.S. ARMY ENGINEER DISTRICT, ALASKA  
REGULATORY DIVISION  
P.O. BOX 6998  
ELMENDORF AFB, ALASKA 99506-0898**

**MAY 21 2009**

Regulatory Division  
POA-2009-445

Mr. Glen D. Martin  
Alaska Power and Telephone Company  
193 Otto Street  
Post Office Box 3222  
Port Townsend, Washington 98368

Dear Sir:

This is in response to your May 1, 2009, application for a Department of the Army (DA) permit, to conduct sample test pits. It has been assigned file number POA-2009-445, Yerrick Creek, which should be referred to in all future correspondence with this office. The project site is located within Sections 1, 2, 11, & 14, T. 18 N., and Section 36, T. 19 N., Range 9 E, Cooper River Meridian; USGS Quad Map Tanacross B-6; Latitude 63.3826° N., Longitude 143.5989° W.; approximately 20 miles west of Tok, Alaska.

DA permit authorization is necessary because your project may involve work in or placement of structures and dredged or fill material into waters of the U.S. under our regulatory jurisdiction.

Based upon the information and plans you provided, we hereby verify that the work described above, which would be performed in accordance with the enclosed plan (sheets 1-5), dated May 2009, is authorized by Nationwide Permit (NWP) No. 6, Survey Activities. NWP No. 6 and its associated Regional and General Conditions can be accessed at our website at [www.poa.usace.army.mil/reg](http://www.poa.usace.army.mil/reg). You must comply with all terms and conditions associated with NWP No. 6.

Further, please note General Condition 26 requires that you submit a signed certification to us once any work and required mitigation are completed. Enclosed is the form for you to complete and return to us.

This verification will be valid for two years from the date of this letter, unless the NWP authorization is modified, suspended, or revoked.

Nothing in this letter excuses you from compliance with other Federal, State, or local statutes, ordinances, or regulations.

You may contact me via email at [allan.g.skinner@usace.army.mil](mailto:allan.g.skinner@usace.army.mil), by mail at the address above, by phone at (907) 753-2797, or toll free from within Alaska at (800) 478-2712, if you have questions or to request paper copies of the jurisdictional determination, regional and/or general conditions. For additional information about our Regulatory Program, visit our web site at [www.poa.usace.army.mil/reg](http://www.poa.usace.army.mil/reg).

Sincerely,

A handwritten signature in cursive script that reads "Allan G. Skinner". The signature is written in dark ink and is positioned below the word "Sincerely,".

Allan G. Skinner  
Regulatory Specialist

Enclosures



Enclosure



**US Army Corps of Engineers  
Alaska District**

Permit Number: POA-2009-445

Name of Permittee: Alaska Power and Telephone Company

Date of Issuance: May 22, 2009

Upon completion of the activity authorized by this permit and any mitigation required by the permit, sign this certification and return it to Mr. Allan G, Skinner at the following address:

U.S. Army Corps of Engineers  
Alaska District  
Regulatory Division  
Post Office Box 6898  
Elmendorf AFB, Alaska 99506-0898

Please note that your permitted activity is subject to a compliance inspection by an U.S. Army Corps of Engineers representative. If you fail to comply with this permit you are subject to permit suspension, modification, or revocation.

I hereby certify that the work authorized by the above-referenced permit has been completed in accordance with the terms and conditions of the said permit, and required mitigation was completed in accordance with the permit conditions.

\_\_\_\_\_  
Signature of Permittee

\_\_\_\_\_  
Date

**6. Survey Activities.** Survey activities, such as core sampling, seismic exploratory operations, plugging of seismic shot holes and other exploratory-type bore holes, exploratory trenching, soil surveys, sampling, and historic resources surveys. For the purposes of this NWP, the term “exploratory trenching” means mechanical land clearing of the upper soil profile to expose bedrock or substrate, for the purpose of mapping or sampling the exposed material. The area in which the exploratory trench is dug must be restored to its pre-construction elevation upon completion of the work. In wetlands, the top 6 to 12 inches of the trench should normally be backfilled with topsoil from the trench. This NWP authorizes the construction of temporary pads, provided the discharge does not exceed 25 cubic yards. Discharges and structures associated with the recovery of historic resources are not authorized by this NWP. Drilling and the discharge of excavated material from test wells for oil and gas exploration are not authorized by this NWP; the plugging of such wells is authorized. Fill placed for roads and other similar activities is not authorized by this NWP. The NWP does not authorize any permanent structures. The discharge of drilling mud and cuttings may require a permit under Section 402 of the Clean Water Act. (Sections 10 and 404)

(BLANK PAGE)

# STATE OF ALASKA

SARAH PALIN, GOVERNOR

## DEPARTMENT OF FISH AND GAME

### DIVISION OF HABITAT

1300 COLLEGE ROAD  
FAIRBANKS, AK 99701-1551  
PHONE: (907) 459-7289  
FAX: (907) 459-7303

## FISH HABITAT PERMIT FH09-III-0128

ISSUED: May 20, 2009  
EXPIRES: December 31, 2009

Mr. Glen D. Martin, Project Manager  
Alaska Power and Telephone Company  
P.O. Box 3222  
Port Townsend, AK 98368

Dear Mr. Martin:

RE: Proposed Instream Equipment Crossings and Geotechnical Exploration  
Yerrick Creek  
Sec 1, 2, 11, & 14, T18N, R9E, and Sec 36, T19N, R9E, CRM; Tanacross B-6 Quad

Pursuant to AS 16.05.841 (Fishway Act), the Alaska Department of Fish and Game (ADF&G), Division of Habitat has reviewed your proposal to cross Yerrick Creek with a tracked excavator at the referenced locations, and to conduct geotechnical exploration within the limits of ordinary high water. Your application dated May 1, 2009 was supplemented with information provided at a meeting between ADF&G and company representatives on May 18 and by email from you on May 20, 2009.

Your proposed operation includes walking a ROBEX 130 LCM-3 or similar tracked excavator from the Alaska Highway approximately 3¼ miles up the floodplain of Yerrick Creek to the proposed Yerrick Creek Hydro Project diversion site to perform exploratory trenching, and return. The work would be accomplished during the late summer or fall low water period, and would make use of dry channels whenever possible. Six crossings of the active channel of Yerrick Creek are proposed, as is travel within the floodplain. Approximately six geotechnical test pits would be dug to a depth of 20 feet. The pits would be located at least 50 feet from any active channels of Yerrick Creek and would be refilled after excavation. Some or all of the excavation areas would be within the limits of ordinary high water of Yerrick Creek.

Yerrick Creek supports resident fish species (including Arctic grayling and Dolly Varden) in the area of your proposed activities. Based upon our review of your plans, your proposed project has the potential to obstruct the efficient passage and movement of fish.

ADF&G recommends that disturbance to vegetation within 50 feet of, but outside the limits of, ordinary high water be avoided to the extent practicable, particularly adjacent to sheer or cut banks. Note that this is not intended to preclude travel across gravel bars vegetated with willow or alder.

In accordance with AS 16.05.841, project approval is hereby given subject to your proposed scope of work and the following stipulations:

- (1) Stream crossings shall be made from bank to bank in a direction substantially perpendicular to the direction of stream flow.
- (2) Stream crossings shall be made only at locations with gradually sloping banks. There shall be no crossings at locations with sheer or cut banks.
- (3) Stream banks and stream beds shall not be altered or disturbed in any way to facilitate crossings. If stream banks are inadvertently disturbed, they shall be immediately stabilized to prevent erosion.
- (4) Log jams and embedded large woody debris within the limits of ordinary high water shall not be moved or removed without specific authorization from ADF&G.
- (5) Any excavation within the limits of ordinary high water shall be reclaimed and stabilized in a manner that is not conducive to erosion and that cannot trap fish under fluctuating water levels. Photo documentation of each reclaimed pit within the limits of ordinary high water shall be forwarded to this office within 30 days of the activity.

The permittee is responsible for the actions of contractors, agents, or other persons who perform work to accomplish the approved plan. For any activity that significantly deviates from the approved plan, the permittee shall notify the ADF&G and obtain written approval in the form of a permit amendment before beginning the activity. Any action taken by the permittee, or an agent of the permittee, that increases the project's overall scope or that negates, alters, or minimizes the intent or effectiveness of any stipulation contained in this permit will be deemed a significant deviation from the approved plan. The final determination as to the significance of any deviation and the need for a permit amendment is the responsibility of the ADF&G. Therefore, it is recommended that the ADF&G be consulted immediately when a deviation from the approved plan is being considered.

**This letter constitutes a permit issued under the authority of AS 16.05.841 and must be retained on site during the permitted activity.** Please be advised that this approval does not relieve you of the responsibility of securing other permits, state, federal or local.

This permit provides reasonable notice from the Commissioner that failure to meet its terms and conditions constitutes violation of AS 16.05.861; no separate notice under AS 16.05.861 is required before citation for violation of AS 16.05.841 can occur.

In addition to the penalties provided by law, this permit may be terminated or revoked for failure to comply with its provisions or failure to comply with applicable statutes and regulations. The ADF&G reserves the right to require mitigation measures to correct disruption to fish and game

created by the project and which was a direct result of the failure to comply with this permit or any applicable law.

The recipient of this permit (permittee) shall indemnify, save harmless, and defend the ADF&G, its agents and its employees from any and all claims, actions or liabilities for injuries or damages sustained by any person or property arising directly or indirectly from permitted activities or the permittee's performance under this permit. However, this provision has no effect, if, and only if, the sole proximate cause of the injury is the ADF&G's negligence.

Please be advised that this determination applies only to activities regulated by the ADF&G; other departments and agencies also may have jurisdiction under their respective authorities. This determination does not relieve you of the responsibility for securing other permits, state, federal, or local. You are still required to comply with all other applicable laws.

Sincerely,

Denby S. Lloyd, Commissioner



BY: Robert F. "Mac" McLean, Regional Supervisor  
Division of Habitat

ecc: Tim Pilon, ADEC, Fairbanks  
Bonnie Borba, ADF&G CF, Fairbanks  
Al Ott, ADF&G HAB, Fairbanks  
Fronty Parker, ADF&G SF, Delta Junction  
Jim Simon, ADF&G SUBS, Fairbanks  
Jeff Gross, ADF&G WC, Tok  
Chris Milles, ADNR DMLW, Fairbanks  
NOAA Fisheries, Anchorage  
Allan Skinner, USACE, Anchorage POA-2009-445  
Larry Bright, USFWS, Fairbanks  
Meg Hayes, Tanacross Inc.  
Eric Hannan, AP&T, Tok

RFM/jdd

(BLANK PAGE)

**From:** [McGee, Lauren - Washington, DC](#)  
**To:** [akmadindian@yahoo.com](#); [Bob Brean](#); [dawndemit@hotmail.com](#); [Dean, Laura - Washington, DC](#); [dolly.h@aptalaska.com](#); [Eric Hannan](#); [Glen Martin](#); [John Harvey](#); [kristie\\_young\\_ak@yahoo.com](#); [Larsen, Karen - Washington, DC](#)  
**Subject:** 11/13/2008 Yerrick Creek Mtg Summary  
**Date:** Wednesday, December 17, 2008 10:20:45 AM  
**Attachments:** [Yerrick Creek mtg agenda.pdf](#)  
[Yerrick Creek Mtg Summary.pdf](#)  
[Yerrick Creek preliminary archaeolog rpt.pdf](#)  
[APC Hydroelectric projects.pdf](#)  
[Tanacross Inc comment 1.pdf](#)  
[RUS Tanacross Inc response.pdf](#)

---

Hi All,

I apologize for the delay in submitting RUS's summary notes for the Yerrick Creek teleconference (11/13/2008). In addition to the notes, a copy of the following is attached:

- teleconference agenda
- preliminary archaeological survey
- synopsis of AP&T's successful hydroelectric projects
- Tanacross, Inc.'s letter re: the potential impacts of the proposal
- RUS's response to Tanacross, Inc.'s letter

If you have any questions about the meeting notes or suggest revisions, please email me or call me at 202.720.1482. Thank you for your participation. We will keep you updated on the progression of the Yerrick Creek proposal.

Regards,

Lauren.

Lauren McGee, Environmental Scientist  
USDA, Rural Development Utilities Programs  
Mail Stop 1571, Rm 2239  
1400 Independence Ave, SW  
Washington, DC 20250  
202.720.1482 (phone)  
202.690.0649 (fax)  
[lauren.mcgee@wdc.usda.gov](mailto:lauren.mcgee@wdc.usda.gov)  
<http://www.usda.gov/rus/water/ees/environ.htm>



**Yerrick Creek Hydroelectric Teleconference Meeting Summary**  
11/13/2008, 10:00 AM – 11:00 AM AST

Participants:

Rural Utilities Service (RUS)

Lauren McGee, Environmental Scientist and Moderator	202-720-1482
Karen Larsen, Management Analyst, Electric Programs	202-720-8787
Laura Dean, Archeologist and Federal Preservation Officer	202-720-9634

Tanacross, Inc.

Robert Brean, President  
Bruce Moore, Attorney  
Meg Hass, Land consultant

Native Village of Tanacross

Dawn Demit, Village Council Secretary

Native Village of Dot Lake

Charles Miller, Tribal Administrator

Native Village of Tetlin

Kristie Young, Tribal Administrator

Alaska Power & Telephone Company (APTC)

Glen Miller, Project Manager  
Eric Hannan, Interior Division Manager and Engineer  
John Harvey  
Dolly Henton, Administrative Assistant/GIS Specialist

---

*\*Notes: (1) Summary is organized according to topic. (2) Details shown in bold, red font indicate uncertainty.*

Introduction of participants

Overview of High Cost Energy Grant Program

- Program began approximately eight years ago.
- Funds can be used for energy generation (including renewables), transmission, distribution, and efficiency improvement proposals.
- APTC's Yerrick Creek proposal received a relatively high ranking and was selected as a potential award recipient for Fiscal Year (FY) 2007 funding.
- Final approval of the proposal is pending completion of all environmental requirements, including compliance with the National Environmental Policy Act (NEPA) and Section 106 of the National Historic Preservation Act and its implementing regulations (36 CFR Part 800).

Purpose of the meeting

- NEPA requirements
  - APTC must complete an environmental impact report compliant with RUS regulations (7 CFR Part 1794) prior to receiving funding.

- The proposal has been classified as an Environmental Assessment (EA) as it would be a new generating facility producing less than 20 MW (§ 1794.23[3]).
  - Once an Environmental Report (ER) is prepared and approved by RUS, the ER would be adopted as RUS's EA and made available for public review. Notification of the ER's availability would occur in local newspapers. The ER would be available for download from RUS's website.
  - RUS would issue a Finding of No Significant Impact (FONSI) if few comments/objections to the proposal were received and if the ER showed that the proposal would not have significant impacts to the human environment. A notice indicating the availability of the FONSI would be published in local newspapers. An additional comment period following the publication of the FONSI would occur also as needed.
  - Tanacross Inc. has requested that all notices for this proposal be submitted by email as the region's local newspaper is only published bimonthly.
  - APTC is in the initial stages of preparing the Yerrick Creek ER. Several studies have commenced based on available literature and site conditions on Alaska State lands. No work has been initiated on Tanacross, Inc. lands.
- Requirements under Section 106 of the National Historic Preservation Act
- Under Section 106, RUS is required to take into account effects of its undertakings on historic properties. The APTC application is an undertaking subject to review under Section 106.
  - The Alaska SHPO serves in an advisory role in Section 106 review and is participating because lands others than tribal lands are involved.
  - Under Section 106, RUS has a responsibility to consult with other parties before reaching a decision on whether or not to provide assistance. This is the first consultation meeting held by the RUS about the APTC undertaking.
  - The Native Village of Tanacross is a federally recognized tribe by the Bureau of Indian Affairs. It is, therefore, the native village of Tanacross which is entitled to government-to-government consultation. However, the native corporation, Tanacross, Inc., owns most of the land and resources of the native village, and shares in the corporation are held by tribal members. Accordingly, Tanacross, Inc. also must participate in consultation since it reflects the interest of tribal members.
  - The letter dated November 10, 2008, from Mr. Bruce Moore, Tanacross Inc. attorney, identified the area of the proposed project as one possessing cultural value to Tanacross Inc. RUS recognizes that this area may contain properties of religious and cultural significance to Native Village of Tanacross, Tetlin and Dot Lake. That is why those parties were invited to consult. However, in order to proceed in its Section 106 review, RUS needs specific information about discrete places of significance to the tribes, such as the trail between Tanacross and the area of Metasta Lake identified in the November 10, 2008, letter.
  - RUS indicated that APTC has not yet conducted the fieldwork necessary to identify historic properties in the area of potential effects.

## Project Description:

- Overview
  - o APTC's methods for power generation have changed from predominately diesel to hydroelectric during the past two decades.
  - o Since the mid 1970s, APTC has considered Yerrick Creek a good site for hydroelectric power generation due to its relatively good hydraulic pressure.
  - o The proposal calls for the diversion of Yerrick Creek water to an 11,000-15,000 foot tunnel that is approximately six inches in diameter. The water exiting the tunnel (or pipe) would power a turbine. The pipe and supporting transmission lines would be buried. Existing transmission infrastructure along the highway would be used.
  - o The local community could see a 20% reduction in utility costs.
  
- Alternatives Considered by APTC:
  - o Electricity generation alternatives – APTC considered hydrokinetic (energy generation from water movement w/o the use of an impoundment or diversion), solar, thermal, and wind. APTC determined that these options would not be feasible as the proposed project area does not have high class wind speeds. Additionally, thermal pockets have not been identified near the proposed project area.
  - o Siting of hydro facilities – APTC has conducted kinetic studies in the Tanana River (a location alternative). This site was considered unfeasible due to river water siltation and bio-material (leaf) accumulation.
  
- Hydro and Migratory Fish Studies
  - o Migratory fish are present in Yerrick Creek. APTC has contacted Alaska State fish and wildlife agencies.
  - o Since water in Yerrick Creek does freeze during the winter, the facility can only run during 6-9 months of the year.
  - o Most water flow is subterranean.
  - o All stream gauging activities have occurred on Alaska State lands.

## General Discussion:

- Prior contact between APTC and Tanacross, Inc.
  - o **Sept/Oct/Nov 2006 (???)**: Tanacross, Inc. had a meeting with APTC. Tanacross, Inc. confirmed that it was not interested in leasing its land for use in the APTC proposal.
  - o On **January 8, 2008 (or 2007?)**, APTC sent a letter to Tanacross, Inc. regarding the lease of land under the control of Tanacross, Inc. for use by APTC's proposal. APTC acknowledged Tanacross, Inc.'s decision.
  - o Tanacross, Inc. did not at that time and currently does not support APTC's proposed use of its lands due to legal contracts and permits that commit the land in question for use in the proposed Denali pipeline project.

- Tanacross, Inc. conceded that it was up to Denali - The Alaska Gas Pipeline, LLC (Denali) to determine if its pipeline and the APTC proposal were compatible uses. However, Tanacross, Inc. would not yield its prior business commitment and do not currently support APTC contacting Denali to assess the feasibility of co-locating both projects on Tanacross, Inc. land.
  - Tanacross Inc. supports the development of cheap, renewable power. However, it is concerned with how APTC's proposal might change the land and the important resources it contains.
  - According to APTC, if Tanacross, Inc. land is not available for use, then the project cannot be constructed as proposed. That means that continued use of diesel generation (the 'No build" alternative) would be the only feasible option.
  - Tanacross, Inc. also is concerned about the multiple documents which state that **Tanacross Village and/or Tanacross, Inc.** is in favor of the APTC proposal.
- Mail/email announcements:
    - Because the local newspaper is printed only bimonthly, Tanacross, Inc. requested that notice of the availability of all documents associated with RUS's environmental review of this proposal be sent by email. This includes a copy of the preliminary archaeological report.
  - Financing of the proposal
    - Given project costs, construction of the proposal would not be possible without support from state and federal grants. APTC would not make a profit on this proposal.
  - Other views:
    - Tetlin and Dot Lake are in support of APTC's proposal.
  - Examples of successful hydroelectric proposals similar to Yerrick Creek
    - APTC discussed the South Fork Hydroelectric Project on Prince Wales Island as a good example.
    - APTC will produce a document for consulting parties of its successful hydroelectric projects.

Next steps:

- RUS will send a summary of this meeting's discussion, the preliminary archaeological survey, and examples of successful APTC hydroelectric proposals by email to consulting parties.

Prepared by: Lauren McGee and Laura Dean